

## CJ2301-HF

**P-Channel**  
**RoHS Device**  
**Halogen Free**

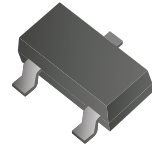

V(BR)DSS	RDS(on)MAX	ID
-20V	112mΩ @ -4.5V	-2.3A
	142mΩ @ -2.5V	

### Features

- P-Channel 20-V(D-S) MOSFET
- Trench FET Power MOSFET.
- Load Switch for Portable Devices.
- DC/DC Converter.

### Mechanical data

- Case: SOT-23, molded plastic.
- Terminals: Solderable per MIL-STD-750, method 2026.
- Weight: 0.008 grams(approx.).

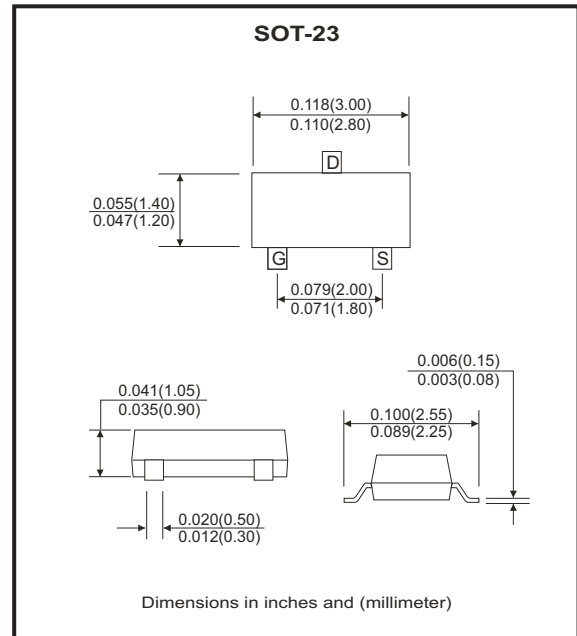

### Circuit diagram

- G : Gate
- S : Source
- D : Drain

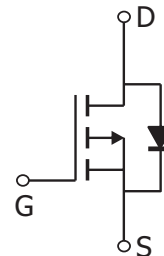

### Maximum Ratings (at Ta=25 °C unless otherwise noted)

Parameter	Symbol	Value	Units
Drain-source voltage	V <sub>DS</sub>	-20	V
Gate-source voltage	V <sub>GS</sub>	±8	V
Continuous drain current	I <sub>D</sub>	-2.3	A
Pulsed drain current	I <sub>DM</sub>	-10	
Continuous source-drain diode current	I <sub>S</sub>	-0.72	
Maximum power dissipation	P <sub>D</sub>	400	mW
Thermal resistance from junction to ambient (t<5s)	R <sub>θJA</sub>	312.5	°C/W
Junction temperature range	T <sub>J</sub>	150	°C
Storage temperature range	T <sub>STG</sub>	-55 to +150	°C

## Electrical Characteristics (at T<sub>A</sub>=25°C unless otherwise noted)

Parameter	Symbol	Conditions	Min	Typ	Max	Units
<b>Static</b>						
Drain-source breakdown voltage	V <sub>(BR) DSS</sub>	V <sub>GS</sub> =0V , I <sub>D</sub> =-250μA	-20			V
Gate-source threshold voltage	V <sub>GS(th)</sub>	V <sub>DS</sub> =V <sub>GS</sub> , I <sub>D</sub> =-250μA	-0.4		-1	
Gate-source leakage	I <sub>GSS</sub>	V <sub>DS</sub> =0V , V <sub>GS</sub> =±8V			±100	nA
Zero gate voltage drain current	I <sub>DSS</sub>	V <sub>DS</sub> =-20V , V <sub>GS</sub> =0V			-1	μA
Drain-source on-state resistance (Note a)	R <sub>DS(on)</sub>	V <sub>GS</sub> =-4.5V , I <sub>D</sub> =-2.8A		0.090	0.112	Ω
		V <sub>GS</sub> =-2.5V , I <sub>D</sub> =-2.0A		0.110	0.142	
Forward transconductance (Note a)	g <sub>fs</sub>	V <sub>DS</sub> =-5V , I <sub>D</sub> =-2.8A		6.5		S
<b>Dynamic (Note b)</b>						
Input capacitance	C <sub>iss</sub>	V <sub>DS</sub> =-10V , V <sub>GS</sub> =0V, f=1MHz		405		pF
Output capacitance	C <sub>oss</sub>			75		
Reverse transfer capacitance	C <sub>rss</sub>			55		
Total gate charge	Q <sub>g</sub>	V <sub>DS</sub> =-10V , V <sub>GS</sub> =-4.5V, I <sub>D</sub> =-3A		5.5	10	nC
				3.3	6	
Gate-source charge	Q <sub>gs</sub>	V <sub>DS</sub> =-10V , V <sub>GS</sub> =-2.5V, I <sub>D</sub> =-3A		0.7		
Gate-drain charge	Q <sub>gd</sub>			1.3		
Gate resistance	R <sub>g</sub>	f=1MHz		6.0		Ω
Turn-on delay time	t <sub>d(on)</sub>	V <sub>DD</sub> =-10V , R <sub>L</sub> =10Ω , I <sub>D</sub> =-1A V <sub>GEN</sub> =-4.5V R <sub>g</sub> =1Ω		11	20	nS
Rise time	t <sub>r</sub>			35	60	
Turn-off delay time	t <sub>d(off)</sub>			30	50	
Fall time	t <sub>f</sub>			10	20	
<b>Drain-source body diode characteristics</b>						
Continuous source-drain diode current	I <sub>S</sub>	T <sub>C</sub> =25°C			-1.3	A
Pulse diode forward current (Note a)	I <sub>SM</sub>				-10	
Body diode voltage	V <sub>SD</sub>	I <sub>S</sub> =-0.7A		-0.8	-1.2	V

### Notes:

- Pulse test: Pulse width <300μs, Duty cycle ≤ 2%
- Guaranteed by design, not subject to production testing.

## RATING AND CHARACTERISTIC CURVES ( CJ2301-HF )

Fig.1 - Output Characteristics

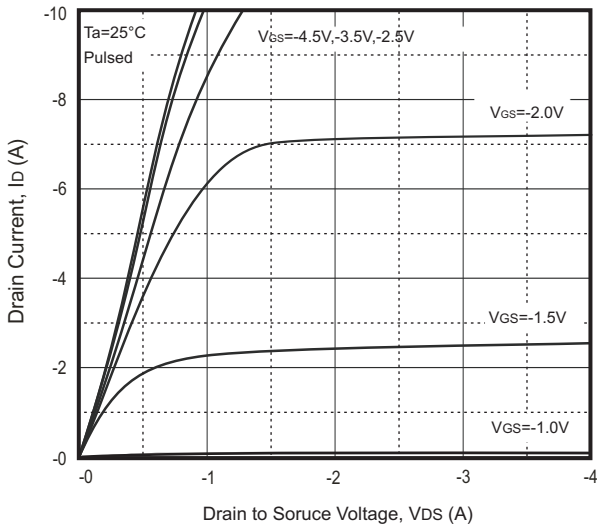

Fig.2 - Transfer Characteristics

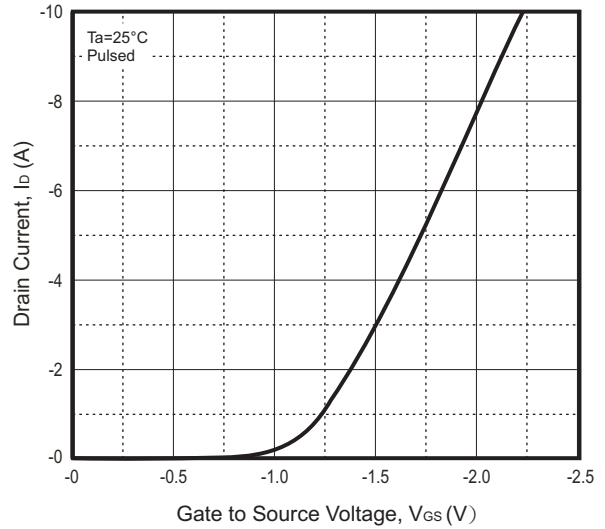

Fig.3 -  $R_{DS(ON)}$  —  $I_D$

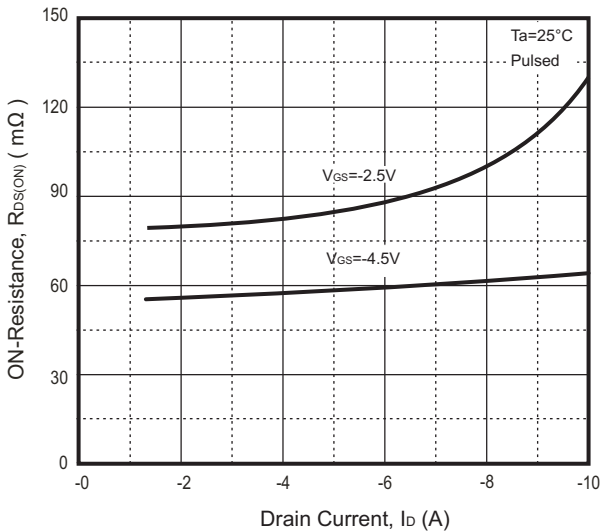

Fig.4 -  $R_{DS(ON)}$  —  $V_{GS}$

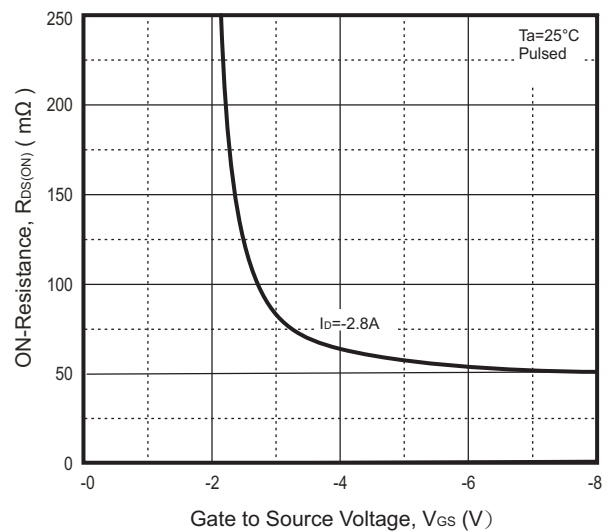
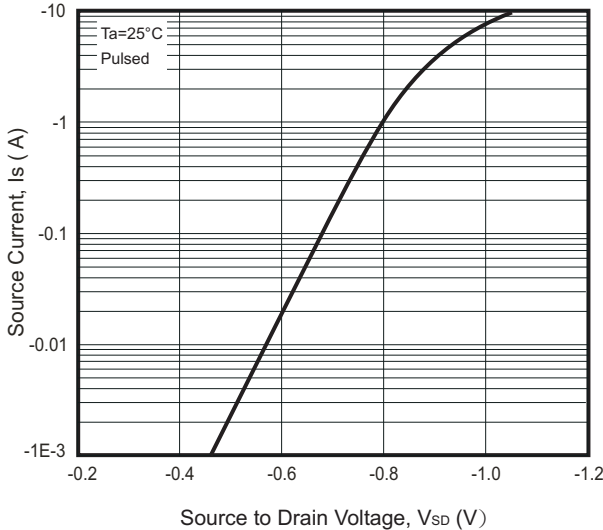
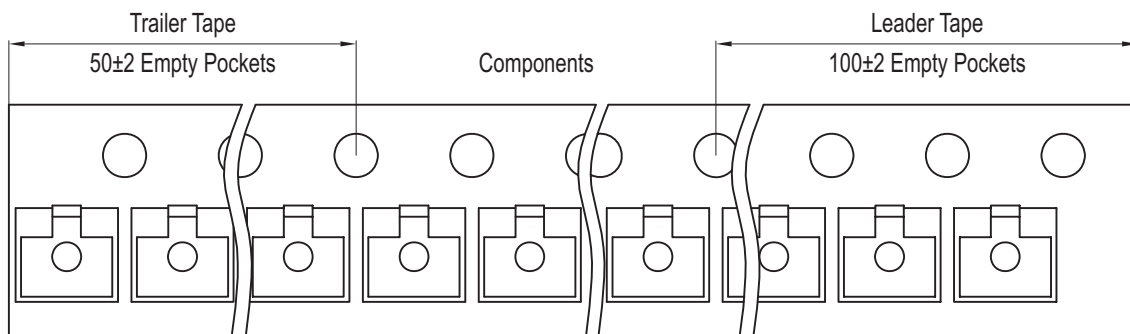
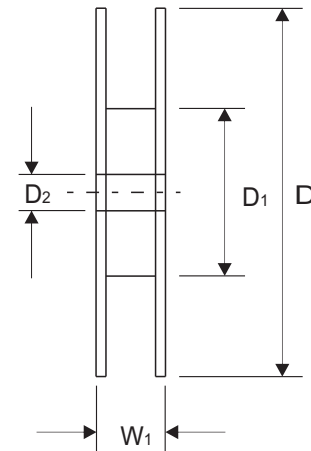
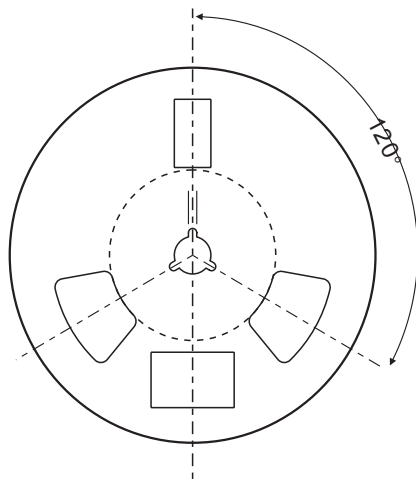
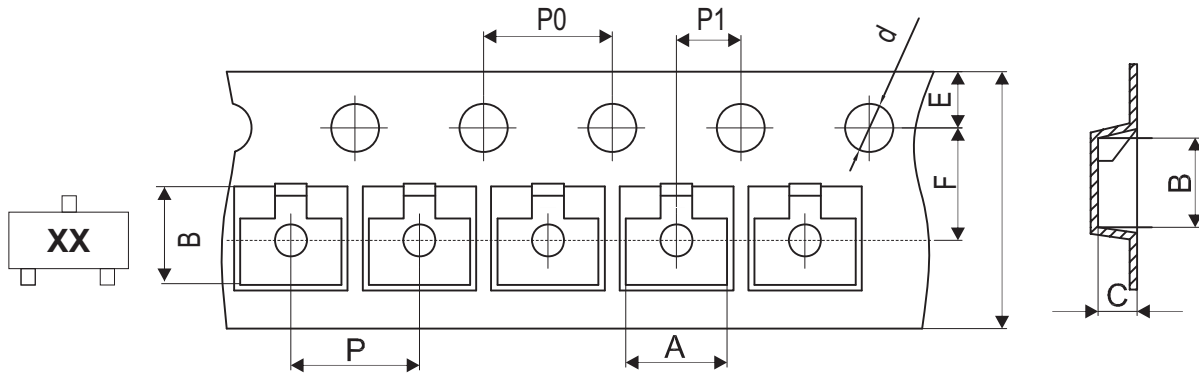

Fig.5 -  $I_S$  —  $V_{SD}$



### Reel Taping Specification



SOT-23	SYMBOL	A	B	C	d	D	D1	D2
	(mm)	3.15 ± 0.10	2.77 ± 0.10	1.22 ± 0.10	1.50 ± 0.10	178.00 ± 2.00	54.40 ± 1.00	13.00 ± 1.00
	(inch)	0.124 ± 0.004	0.109 ± 0.004	0.048 ± 0.004	0.059 ± 0.004	7.008 ± 0.079	2.142 ± 0.039	0.512 ± 0.039

SOT-23	SYMBOL	E	F	P	P0	P1	W	W1
	(mm)	1.75 ± 0.10	3.50 ± 0.10	4.00 ± 0.10	4.00 ± 0.10	2.00 ± 0.10	8.00 + 0.30 / - 0.10	12.30 ± 1.00
	(inch)	0.069 ± 0.004	0.138 ± 0.004	0.157 ± 0.004	0.157 ± 0.004	0.079 ± 0.004	0.315 + 0.012 / - 0.004	0.484 ± 0.039

Company reserves the right to improve product design , functions and reliability without notice.

## Marking Code

Part Number	Marking Code
CJ2301-HF	S1

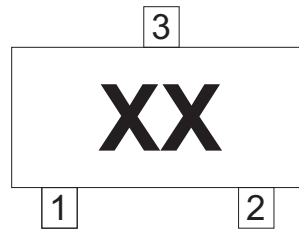

xx = Product type marking code

## Suggested PAD Layout

SIZE	SOT-23	
	(mm)	(inch)
A	0.80	0.031
B	0.60	0.024
C	1.90	0.075
D	2.02	0.080
E	2.82	0.111

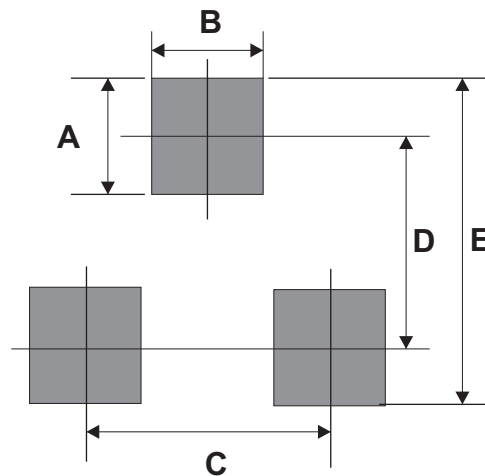

## Standard Packaging

Case Type	Qty Per Reel	Reel Size
	(Pcs)	(inch)
SOT-23	3,000	7