

MBR6030PT-G Thru. MBR60100PT-G

Reverse Voltage: 30 to 100V

Forward Current: 60.0A

RoHS Device

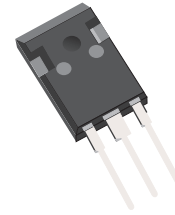

Features

- Low power loss, high efficiency.
- Low reverse leakage current.
- Guard ring for overvoltage protection.
- High Surge Current Capability.

Mechanical Data

- Epoxy: UL 94V-0 rate flame retardant.
- Case: TO-3P Molded plastic.
- Terminals: Pure tin plated, lead free solderable per MIL-STD-750, Method 2026
- Polarity: As marked.
- Mounting position: Any

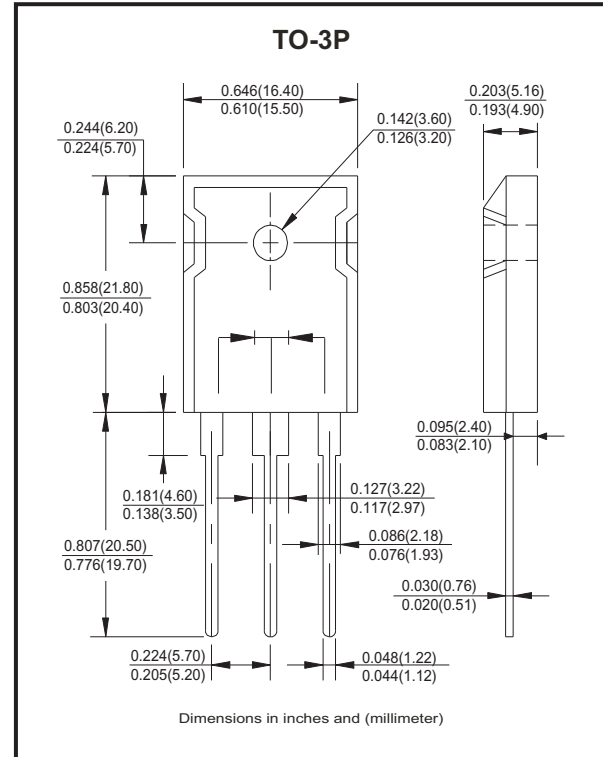

Maximum Ratings And Electrical Characteristics

Rating at 25°C ambient temperature unless otherwise specified.
Single phase, half wave, 60Hz, resistive or inductive load.
For capacitive load, derate current by 20%

Parameter	Symbol	MBR60 30PT-G	MBR60 40PT-G	MBR60 45PT-G	MBR60 50PT-G	MBR60 60PT-G	MBR60 80PT-G	MBR60 100PT-G	Unit
Maximum Recurrent Peak Reverse Voltage	V_{RRM}	30	40	45	50	60	80	100	V
Maximum RMS Voltage	V_{RMS}	21	28	31.5	35	42	56	70	V
Maximum DC Blocking Voltage	V_{DC}	30	40	45	50	60	80	100	V
Maximum Average Forward Rectified Current (See Fig.1)	$I_{(AV)}$	60							A
Peak Forward Surge Current, 8.3ms Single Half Sine-Wave Super Imposed On Rated Load (JEDEC Method)	I_{FSM}	500							A
Maximum Forward Voltage at 30.0A per leg	V_F	0.65			0.75		0.85		V
Maximum DC Reverse Current At Rated DC Blocking Voltage	@ $T_A=25^\circ C$	20							mA
	@ $T_A=100^\circ C$	200							
Typical Thermal Resistance	$R_{\theta JC}$	1.4							$^\circ C/W$
Operating Temperature Range	T_J	-55 to +150							$^\circ C$
Storage Temperature Range	T_{STG}	-55 to +150							$^\circ C$

Notes: 1. Mounted on 14mm x 14mm pad areas, 1oz. FR4 P.C.B.
2. Free air, mounted on recommended copper pad area.
3. Pulse Test: 300us pulse width, 1% duty cycle.
4. Pulse Test: Pulse width \leq 40ms.

Company reserves the right to improve product design, functions and reliability without notice.

REV: B

Rating and Characteristics Curves (MBR6030PT-G Thru. MBR60100PT-G)

Fig.1 - Forward Current Derating Curve

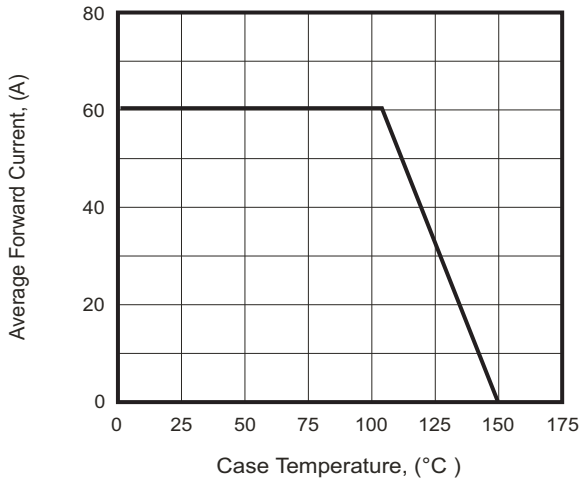

Fig.2 - Typical Forward Characteristics

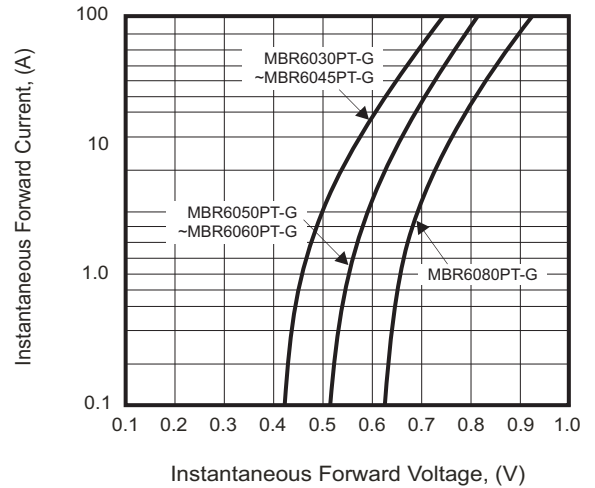

Fig.3 - Maximum Non-Repetitive Surge Current

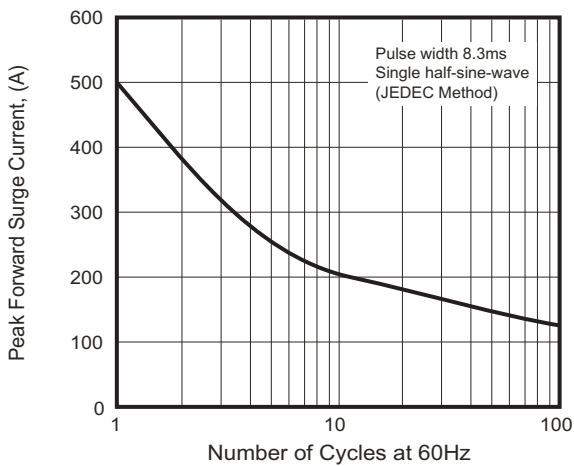
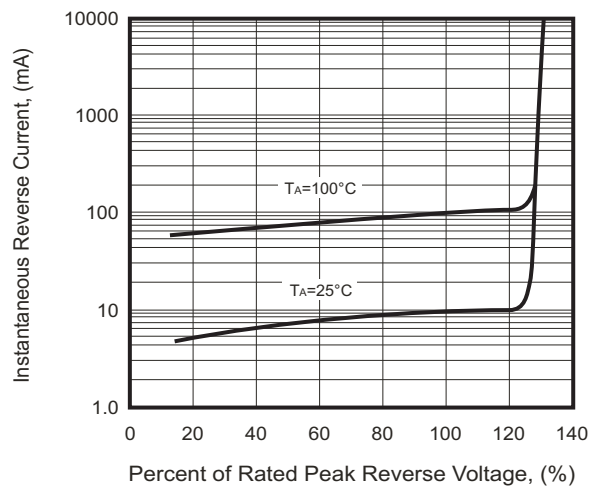
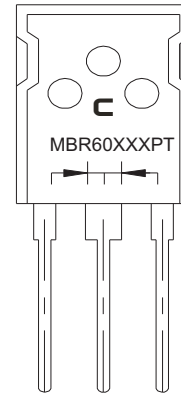

Fig.4 - Typical Revers Characteristics



Marking Code

Part Number	Marking code
MBR6030PT-G	MBR6030PT
MBR6040PT-G	MBR6040PT
MBR6045PT-G	MBR6045PT
MBR6050PT-G	MBR6050PT
MBR6060PT-G	MBR6060PT
MBR6080PT-G	MBR6080PT
MBR60100PT-G	MBR60100PT



XX / XXX = Product type marking code
C = Comchip Logo

Standard Packaging

Case Type	TUBE PACK	
	TUBE (pcs)	BOX (pcs)
TO-3P	30	360