

REVISION RECORD

REV	ECN	DESCRIPTION	DRFT	DATE
-----	-----	-------------	------	------

NOTES1:

UL Standard

1. Rated voltage/current : 600V / 30A
2. Withstanding voltage : AC2200V/1Min.
3. Torque value : M3 , 4.43Lb.in
4. Wire range : 22~10AWG

IEC Standard

1. Pollution degree	3
Overvoltage category	III
Rate impulse voltage(KV)	8KV
Rate voltage(V)	1000V
Rate current(A)	32A

2. Torque value : M3 , 0.5N·m
3. Wire range : 0.5~4mm²

NOTES2:

1. Dimension shall be interpreted per ASME Y14.5-2009
2. Pitch : 6.1mm, Poles : N=01P
3. Stripping length : 8~9mm
4. Operating temperature: -40°C~+105°C
5. Undimensioned tolerances:

Pitch Range In mm		Nominal Dimension Range In mm						- / □	
To	Over	To	Over	To	Over	To	Over	0.1/10	∠
6	10	10	24	30	60	100	150		
±0.15	±0.20	±0.30	±0.30	±0.50	±0.70	±1.00	±1.30	±2'	

6. RoHS Compliance

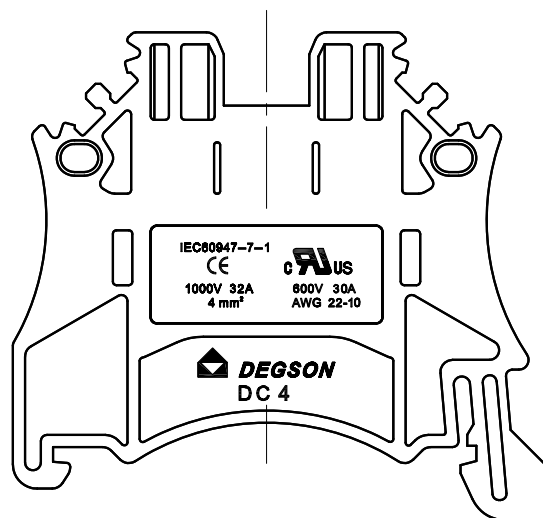
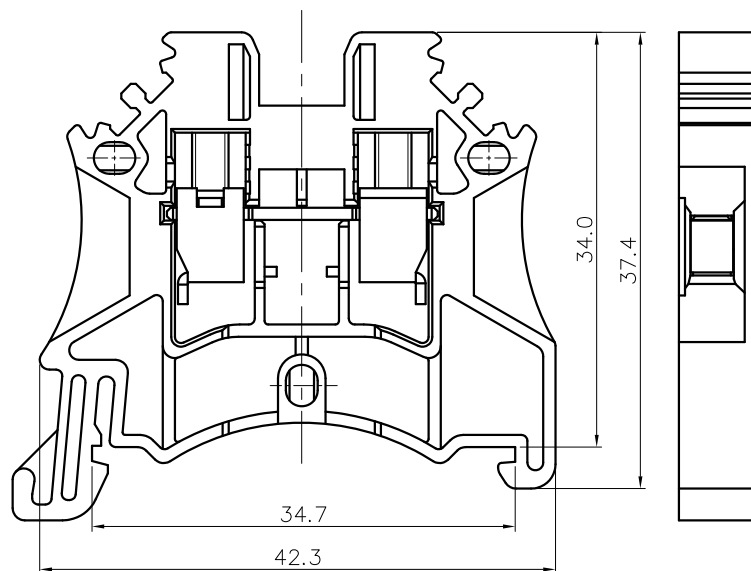
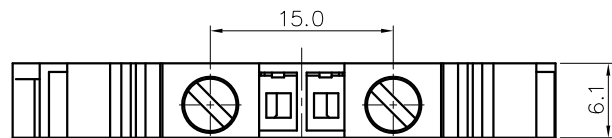

DC4 - 01P - 1Y - 00A (H)

(Series No.) (Poles) (Single Pitch) (Color):

(RoHS)
00A-(Standard)
1.(Grey)
2.(Blue)
3.(Black)
4.(Green)
5.(Orange)
6.(Red)
7.(Transparent)
8.(Yellow)
9.(White)

DETACHED LISTS	PART NO.:	NINGBO DEGSON ELECTRICAL CO., LTD		
	APPD:	NAME: DC4-01P-1Y-00A(H)		
	CHKD:	TITLE: CUSTOMER DRAWING		
	DRFT:	DRAWING NO.:	REV	D0
	THIRD ANGLE PROJECTION		SHEET	1/1
		DO NOT SCALE DRAWING	SCALE	1:1