

REVISION RECORD

| REV | ECN | DESCRIPTION | DRFT | DATE |
|-----|-----|-------------|------|------|
|-----|-----|-------------|------|------|

NOTES1:

UL Standard

1. Rated voltage/current : 300V / 66A
2. Withstanding voltage : AC1600V/1Min.
3. Wire range : 20~4AWG

IEC Standard

| 1. | Pollution degree | 2 | 2 | 3 |
|----|--------------------------|-------|-------|-------|
| | Overvoltage category | II | III | III |
| | Rate impulse voltage(KV) | 8.0KV | 8.0KV | 8.0KV |
| | Rate voltage(V) | 1000V | 1000V | 1000V |
| | Rate current(A) | 76A | | |

2. Wire range : 0.75~16.0mm²

NOTES2:

1. Dimension shall be interpreted per ASME Y14.5-2009
2. Pitch : 10.00mm, Poles : N=01~XXP
3. Stripping length : 17~18mm
4. Operating temperature: -40°C~+105°C
5. Undimensioned tolerances:

| Pitch range in mm | | Nominal dimension range in mm | | | | | - | ∠ | □ |
|-------------------|--------------|-------------------------------|---------------|----------------|-----------------|----------|--------|-------|---|
| TO 6 | Over 6 TO 10 | Over 10 TO 24 | Over 30 TO 60 | Over 60 TO 100 | Over 100 TO 150 | Over 150 | 0.1/10 | | |
| | ±0.15 | ±0.20 | ±0.30 | ±0.30 | ±0.50 | ±0.70 | ±1.00 | ±1.30 | |
| | | | | | | | ±2' | | |

6. RoHS Compliance

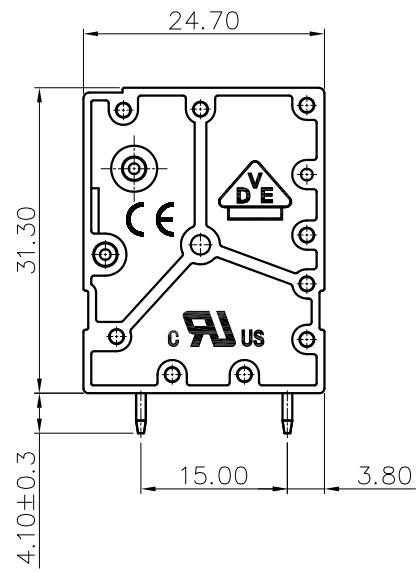
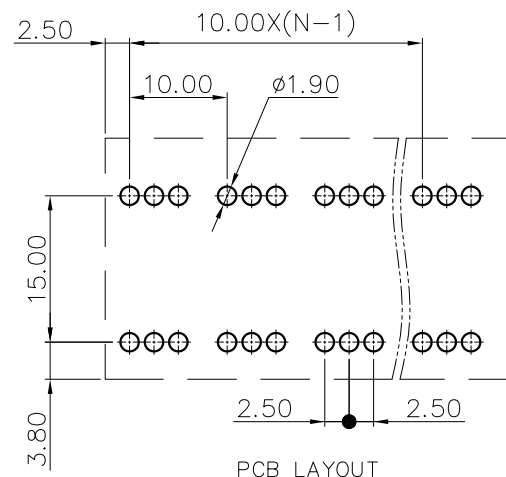
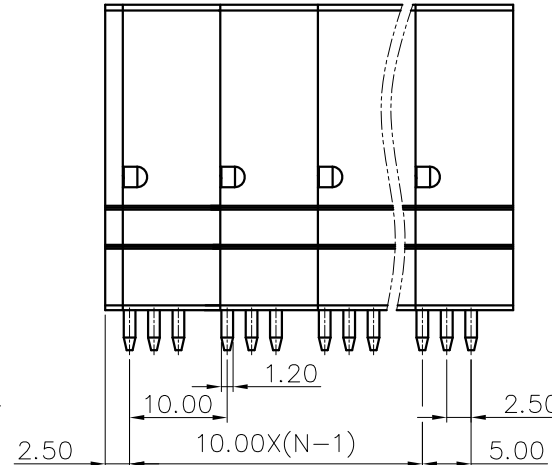
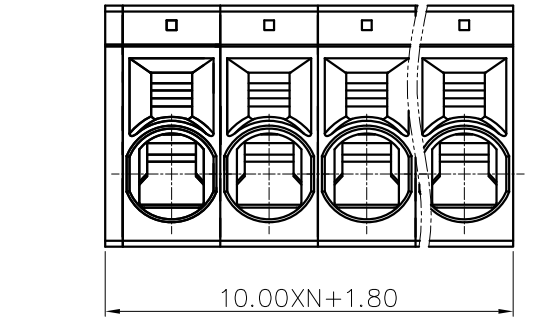
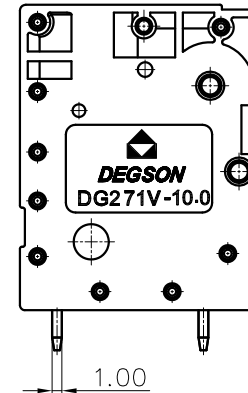

DG271V - 10.0 - XXP - 1Y - 00A (H)

(Series No.) (Pitch) (Poles) (Single Pitch) (Color): 1.(Grey)
 2.(Blue)
 3.(Black)
 4.(Green)
 5.(Orange)
 6.(Red)
 7.(Transparent)
 8.(Yellow)
 9.(White)

| | | | | | |
|----------------|------------------------|--------|--------------|-----------------------------------|---|
| DETACHED LISTS | PART NO.: | / | | | |
| | APPD: | / | | | |
| | CHKD: | / | | | |
| | DRFT: | / | | | |
| | THIRD ANGLE PROJECTION | | DRAWING NO.: | | / |
| | | NAME: | | NINGBO DEGSON ELECTRICAL CO., LTD | |
| | | TITLE: | | CUSTOMER DRAWING | |
| | | REV | | DO | |
| | | SHEET | | 1/1 | |
| | | SCALE | | 1:1 | |