



# External Drive Piezo Transducer Specification

## Series FZ-V1098

Model Number: 109PA18400LFPH

Version 1.0

Address: 28 Genting Lane, #08-07 Platinum 28, Singapore 349585

Tel: +65-6493 5035

Fax: +65-6493 5037

Website: <http://www.flezon.com>

Email: [flezon@flezon.com](mailto:flezon@flezon.com)

# 1. ELECTRICAL SPECIFICATIONS



**Model No.:** 109PA18400LFPH

**Description:** PZ TRANSDUCER 3V PIN PBT SP RoHS

<i>MODEL NO.</i>	<u>109PA18400LFPH</u>
<i>SOUND PRESSURE LEVEL</i>	85.0 dBA Min. ( 3.0V rms Sine Wave , 10 cm , 4000 Hz )
<i>CAPACITANCE</i>	12000 pF ± 30 % at 120 Hz
* <i>MAX. INPUT VOLTAGE</i>	30.0 V p-p
<i>OPERATING TEMPERATURE</i>	- 20 ~ + 60 ° C
<i>TERMINAL</i>	PIN
<i>HOUSING MATERIAL</i>	PBT
* <i>WEIGHT</i>	2.0 g

FLEZON CONFIDENTIAL

## 2. PHYSICAL DIMENSION



All dimensions stated are in mm

Tolerance:  $\pm 0.5\text{mm}$

### TOP VIEW

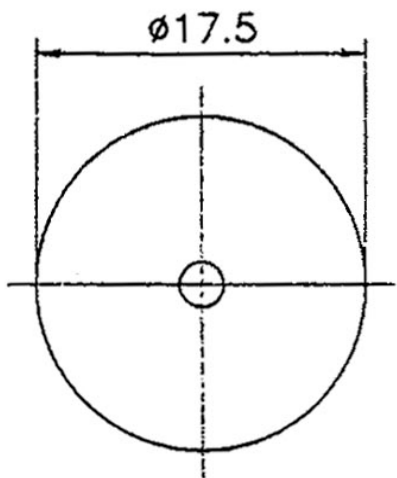

### SIDE VIEW

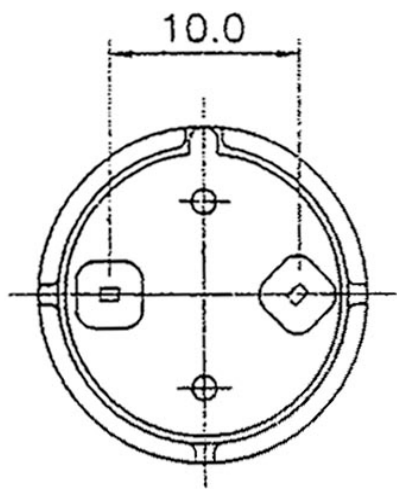
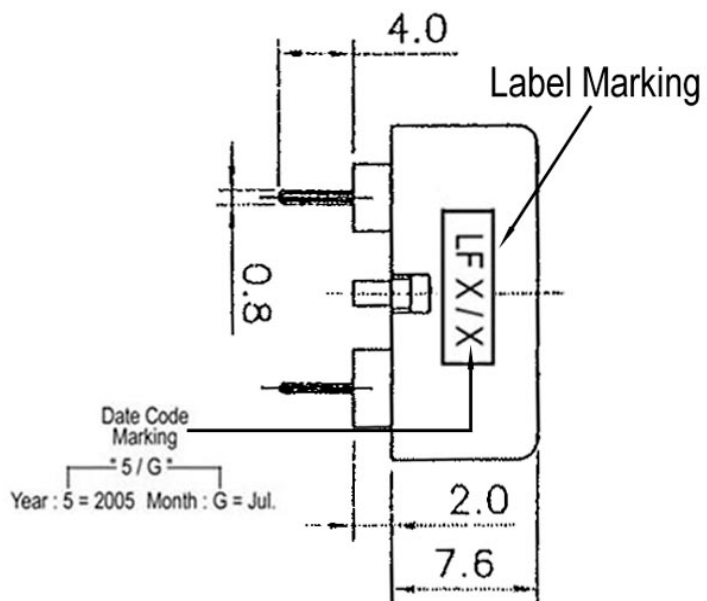

### BOTTOM VIEW

## Revision History

Revision	Date	Description
1.0	2006/07	14000 pF change to 12000 pF

FLEZON CONFIDENTIAL