



External Drive Piezo Transducer Specification

Series FZ-V1108

Model Number: 110PA13400ALFPH

Version 1.0

Address: 28 Genting Lane, #08-07 Platinum 28, Singapore 349585

Tel: +65-6493 5035

Fax: +65-6493 5037

Website: <http://www.flezon.com>

Email: flezon@flezon.com

1. ELECTRICAL SPECIFICATIONS



Model No.: 110PA13400ALFPH

Description: PZ TRANSDUCER 5V PIN PBT SP ROHS

<i>MODEL NO.</i>	<u>110PA13400ALFPH</u>
<i>SOUND PRESSURE LEVEL</i>	80.0 dBA min. (5.0 V p-p Square Wave , 10 cm , 4000 Hz)
<i>CAPACITANCE</i>	14000 pF \pm 30 % at 120 Hz
* <i>MAX. INPUT VOLTAGE</i>	30.0 V p-p
<i>OPERATING TEMPERATURE</i>	-20 ~ +60 ° C
<i>TERMINAL</i>	PIN
<i>HOUSING MATERIAL</i>	PBT
* <i>WEIGHT</i>	2.0 g

2. PHYSICAL DIMENSION



All dimensions stated are in mm

Tolerance: $\pm 0.5\text{mm}$

SIDE VIEW

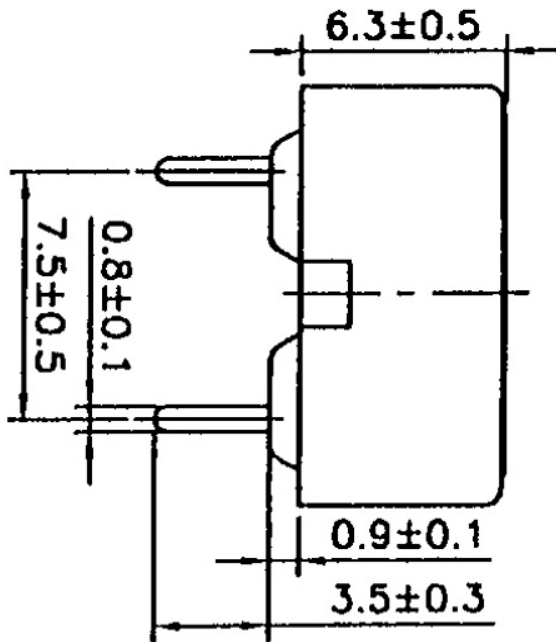

TOP VIEW

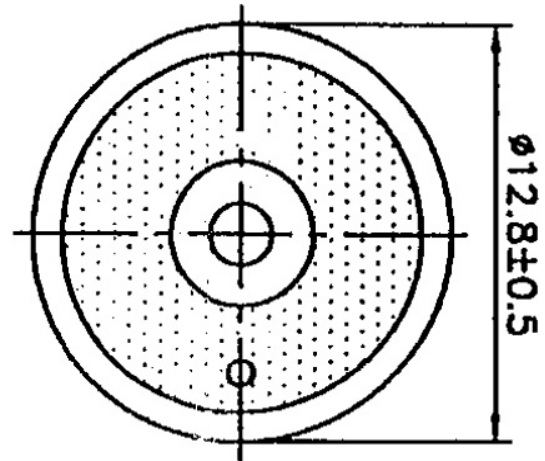

FLEZ

Revision History

Revision	Date	Description
1.0	2005/04	First release

FLEZON CONFIDENTIAL