



External Drive Piezo Transducer Specification

Series FZ-V1198

Model Number: 119PA15500LFRMP

Version 1.0

Address: 28 Genting Lane, #08-07 Platinum 28, Singapore 349585

Tel: +65-6493 5035

Fax: +65-6493 5037

Website: <http://www.flezon.com>

Email: flezon@flezon.com

1. ELECTRICAL SPECIFICATIONS



Model No.: 119PA15500LFRMP

Description: PZ TRANSDUCER 12V SMD PPS SP
1) TAPE & REEL PACKING 2) RoHS

<i>MODEL NO.</i>	<u>119PA15500LFRMP</u>
<i>SOUND PRESSURE LEVEL</i>	85 dBA min. (12.0 V p-p Square Wave , 10 cm , 5000 Hz)
<i>CAPACITANCE</i>	12000 pF \pm 30 % at 120 Hz
* <i>MAX. INPUT VOLTAGE</i>	40 V p-p
<i>OPERATING TEMPERATURE</i>	-20 ~ +70 ° C
<i>TERMINAL</i>	SMD
<i>HOUSING MATERIAL</i>	PPS
* <i>WEIGHT</i>	2.0 g

FLEZON CONFIDENTIAL

2. PHYSICAL DIMENSION

All dimensions stated are in mm

Tolerance: $\pm 0.5\text{mm}$

TOP VIEW

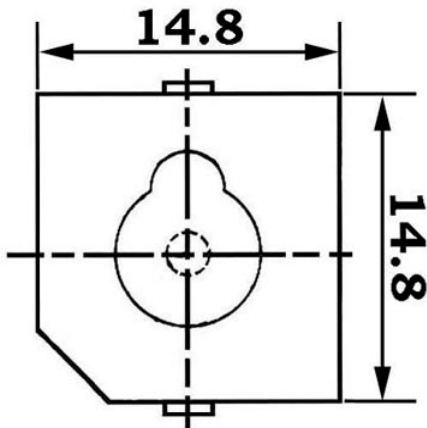

SIDE VIEW

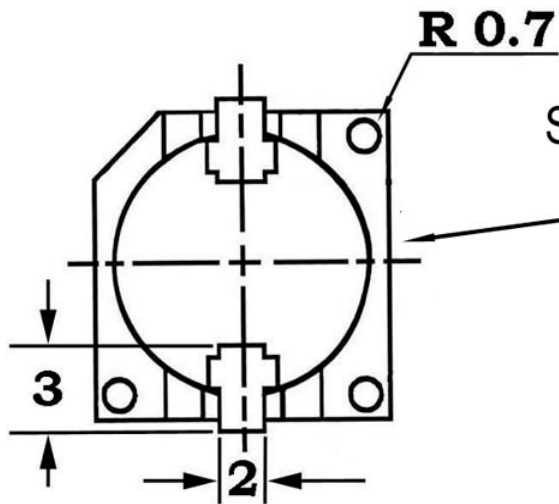
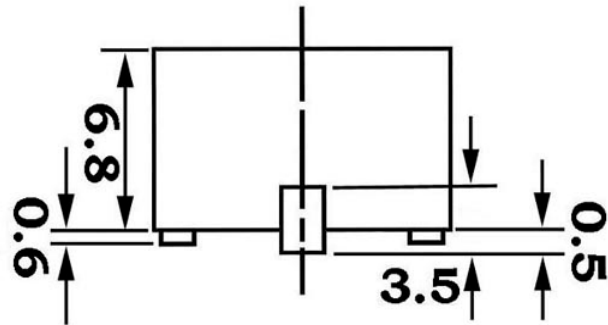

Silk Screen Marking

"LF XX"

Date Code Marking
 "5 / K"
 Year | Month
 5 = 2005 | K = Nov.

BOTTOM VIEW

Revision History

Revision	Date	Description
1.0	2005/11	First release

FLEZON CONFIDENTIAL