



External Drive Piezo Transducer Specification

Series FZ-V1208

Model Number: 120PA17280LFLA

Version 1.0

Address: 28 Genting Lane, #08-07 Platinum 28, Singapore 349585

Tel: +65-6493 5035

Fax: +65-6493 5037

Website: <http://www.flezon.com>

Email: flezon@flezon.com

1. ELECTRICAL SPECIFICATIONS



Model No.: 120PA17280LFLA

Description: PZ TRANSDUCER 3V L/W ABS SP RoHS

<i>MODEL NO.</i>	<u>120PA17280LFLA</u>
<i>SOUND PRESSURE LEVEL</i>	80.0 dBA min. (3.0V rms Sine Wave , 10 cm , 2800 Hz)
<i>CAPACITANCE</i>	23000 pF ± 30 % at 1000 Hz
* <i>MAX. INPUT VOLTAGE</i>	30.0 V p-p
<i>OPERATING TEMPERATURE</i>	-20 ~ +70 ° C
<i>TERMINAL</i>	LEADWIRE (UL1571 , AWG#30)
<i>HOUSING MATERIAL</i>	ABS
* <i>WEIGHT</i>	1.0 g

FLEZON CONFIDENTIAL

2. PHYSICAL DIMENSION

All dimensions stated are in mm

Tolerance: ± 0.5 mm

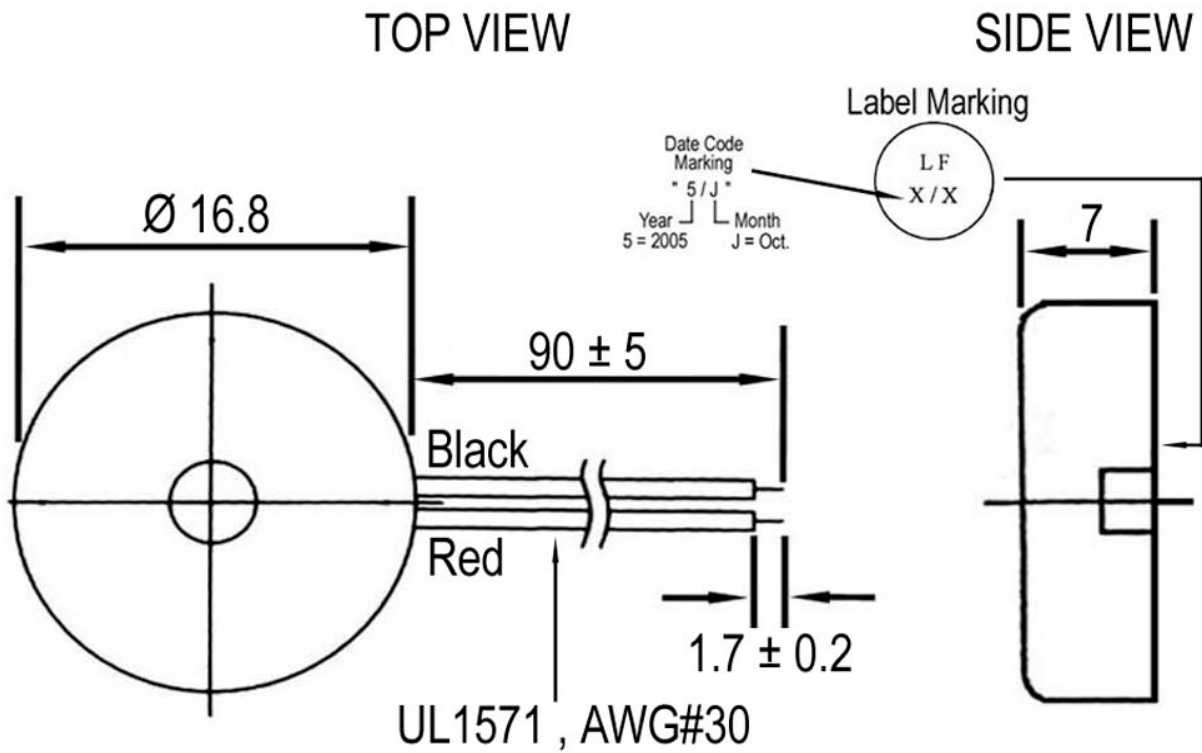

FLEZON

Revision History

Revision	Date	Description
1.0	2005/10	First release

FLEZON CONFIDENTIAL