



External Drive Piezo Transducer Specification

Series FZ-V1618

Model Number: 161PA28420FLM

Version 1.0

Address: 28 Genting Lane, #08-07 Platinum 28, Singapore 349585

Tel: +65-6493 5035

Fax: +65-6493 5037

Website: <http://www.flezon.com>

Email: flezon@flezon.com

1. ELECTRICAL SPECIFICATIONS



Model No.: 161PA28420FLM

Description PZ TRANSDUCER 9V L/W ALUMINUM SP
1) HEIGHT 2.1mm 2) RoHS

<i>MODEL NO.</i>	<u>161PA28420FLM</u>
<i>SOUND PRESSURE LEVEL</i>	85.0 dBA min. (9.0V p-p Square Wave , 10 cm , 4200 Hz)
<i>CAPACITANCE</i>	35000 pF ± 30 % at 1000 Hz
* <i>MAX. INPUT VOLTAGE</i>	40.0 V p-p
<i>OPERATING TEMPERATURE</i>	-30 ~ +80 ° C
<i>TERMINAL</i>	LEADWIRE (UL1007 , AWG#28)
<i>HOUSING MATERIAL</i>	ALUMINUM
* <i>WEIGHT</i>	2.0 g

FLEZON CONFIDENTIAL

2. PHYSICAL DIMENSION



All dimensions stated are in mm

Tolerance: $\pm 0.5\text{mm}$

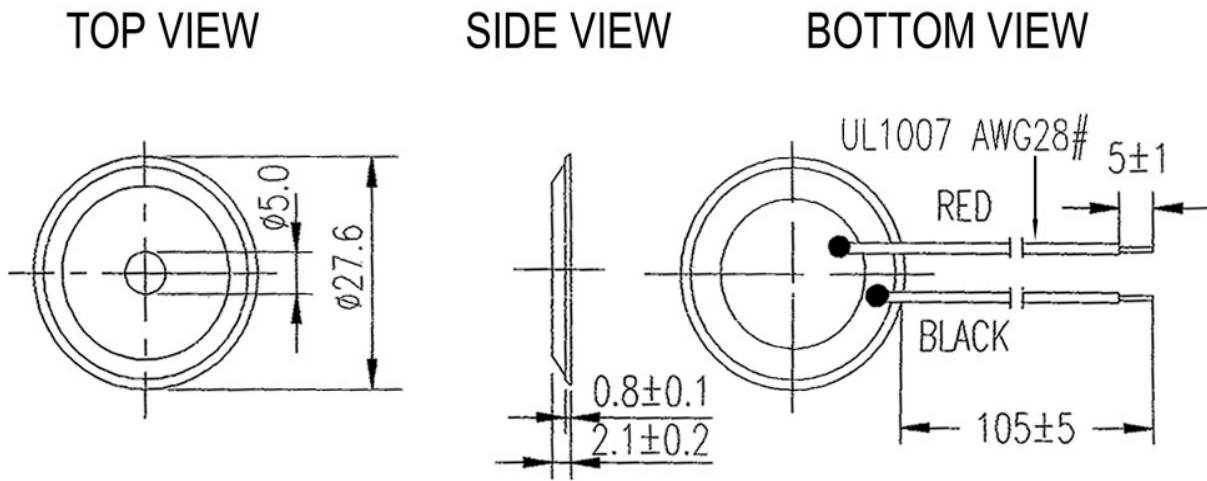

FLEZON.COM

Revision History

Revision	Date	Description
1.0	2005/05	First release

FLEZON CONFIDENTIAL