



External Drive Piezo Transducer Specification

Series FZ-V1858

Model Number: 185PA10320LFLA

Version 1.0

Address: 28 Genting Lane, #08-07 Platinum 28, Singapore 349585

Tel: +65-6493 5035

Fax: +65-6493 5037

Website: <http://www.flezon.com>

Email: flezon@flezon.com

1. ELECTRICAL SPECIFICATIONS



Model No.: 185PA10320LFLA

Description: PZ TRANSDUCER 10V 90mm LL ABS RoHS

<i>MODEL NO.</i>	185PA10320LFLA
<i>SOUND PRESSURE LEVEL</i>	80 dBA min. (10V p-p Square Wave,10cm,3.2KHz)
<i>CAPACITANCE</i>	11000 pF \pm 30 % at 120Hz
* <i>MAX. INPUT VOLTAGE</i>	30 V p-p
* <i>OPERATING TEMPERATURE</i>	-20 ~ +70 ° C
<i>TERMINAL</i>	LEADWIRE
<i>HOUSING MATERIAL</i>	ABS
* <i>WEIGHT</i>	1 g

FLEZON CONFIDENTIAL

2. PHYSICAL DIMENSION



All dimensions stated are in mm

Tolerance: $\pm 0.5\text{mm}$

SIDE VIEW

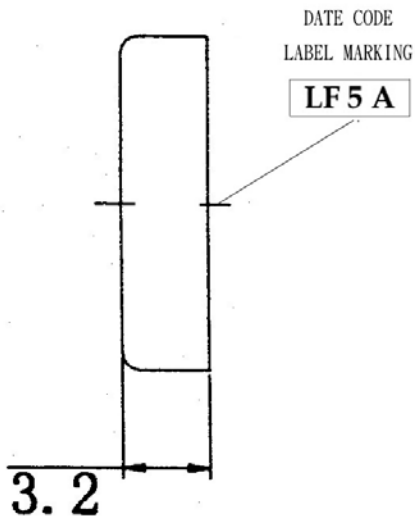

TOP VIEW

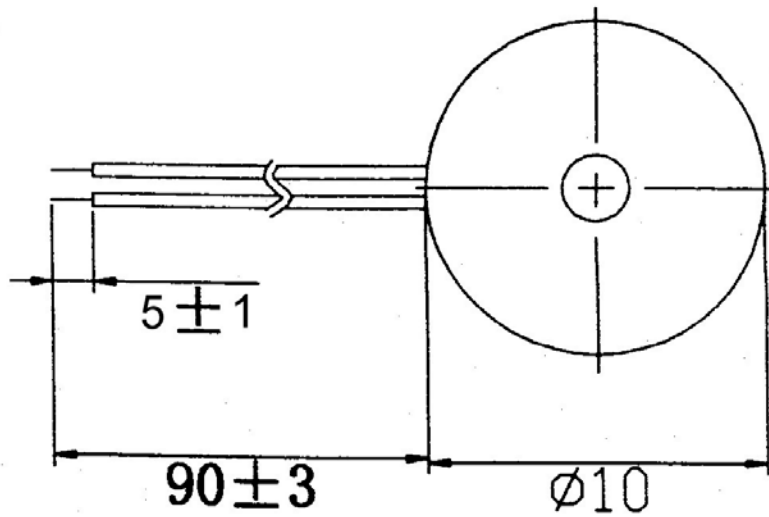

FLEZON

Revision History

Revision	Date	Description
1.0	2008/05	From silk screen marking change to label marking.

FLEZON CONFIDENTIAL