



External Drive Piezo Transducer Specification

Series FZ-V518

Model Number: 51PA23500LFLA

Version 1.0

Address: 28 Genting Lane, #08-07 Platinum 28, Singapore 349585

Tel: +65-6493 5035

Fax: +65-6493 5037

Website: <http://www.flezon.com>

Email: flezon@flezon.com

1. ELECTRICAL SPECIFICATIONS



Model No.: 51PA23500FLA

Description PZ TRANSDUCER 12V L/W ABS SP RoHS

<i>MODEL NO.</i>	51PA23500FLA
<i>SOUND PRESSURE LEVEL</i>	70 dBA min. (12VP-P Square wave, 30 cm, 5000 Hz)
<i>CAPACITANCE</i>	15000 pF ± 30 % at 120 Hz
* <i>MAX. INPUT VOLTAGE</i>	40 V p-p
* <i>OPERATING TEMPERATURE</i>	-20 ~ +60 ° C
<i>TERMINAL</i>	LEADWIRE
<i>HOUSING MATERIAL</i>	ABS
* <i>WEIGHT</i>	2 g

FLEZON CONFIDENTIAL

2. PHYSICAL DIMENSION



All dimensions stated are in mm

Tolerance: $\pm 0.5\text{mm}$

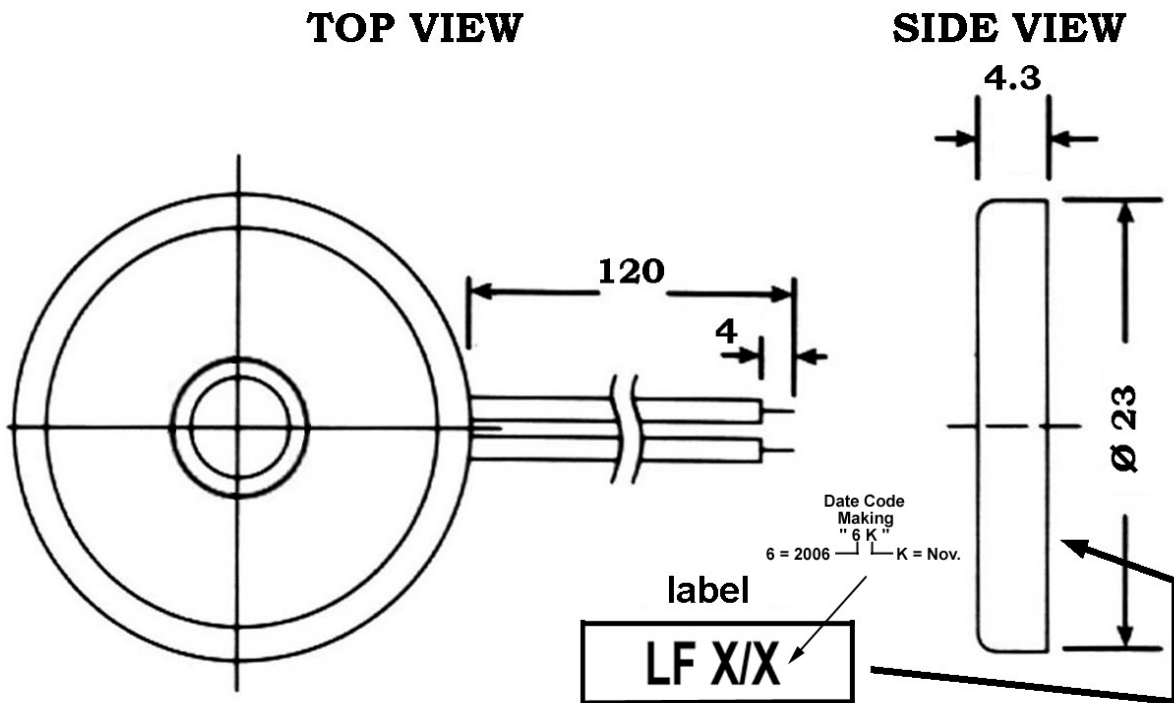

FLEZON

Revision History

Revision	Date	Description
1.0	2006/11	First release

FLEZON CONFIDENTIAL