



# External Drive Piezo Transducer Specification

## Series FZ-V538

Model Number: 53PA17400LFPN

Version 1.0

Address: 28 Genting Lane, #08-07 Platinum 28, Singapore 349585

Tel: +65-6493 5035

Fax: +65-6493 5037

Website: <http://www.flezon.com>

Email: [flezon@flezon.com](mailto:flezon@flezon.com)

# 1. ELECTRICAL SPECIFICATIONS



**Model No.:** 53PA17400LFPN

**Description:** PZ TRANSDUCER 3V PIN NORYL SP RoHS

<i>MODEL NO.</i>	<b>53PA17400LFPN</b>
<i>SOUND PRESSURE LEVEL</i>	75.0 dBA min. ( 3.0V p-p Square Wave , 10 cm , 4000 Hz )
<i>CAPACITANCE</i>	10000 pF ± 30 % at 1000 Hz
* <i>MAX. INPUT VOLTAGE</i>	25.0 V p-p
<i>OPERATING TEMPERATURE</i>	-20 ~ +60 ° C
<i>TERMINAL</i>	PIN
<i>HOUSING MATERIAL</i>	NORYL
* <i>WEIGHT</i>	5.0 g

FLEZON CONFIDENTIAL

## 2. PHYSICAL DIMENSION



All dimensions stated are in mm

Tolerance:  $\pm 0.5\text{mm}$

### Top View

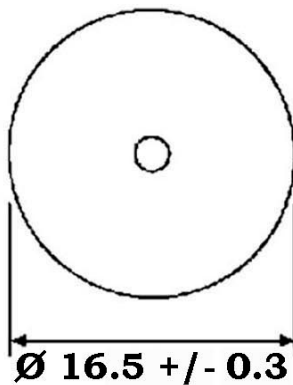

### Side View

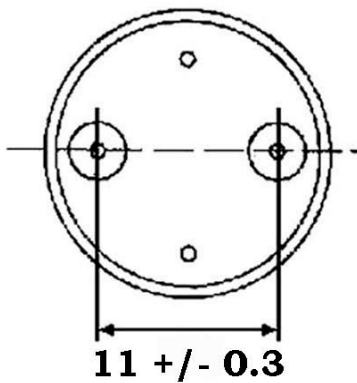
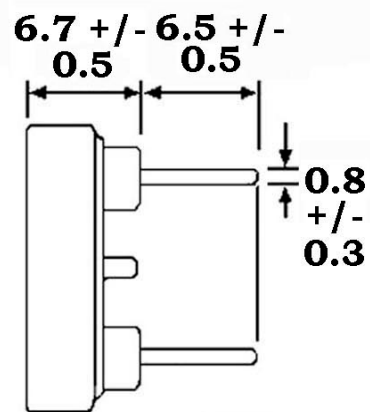

### Bottom View

## Revision History

Revision	Date	Description
1.0	2005/03	First release

FLEZON CONFIDENTIAL