



External Drive Piezo Transducer Specification

Series FZ-V588

Model Number: 58PA34120ULFLA

Version 1.0

Address: 28 Genting Lane, #08-07 Platinum 28, Singapore 349585

Tel: +65-6493 5035

Fax: +65-6493 5037

Website: <http://www.flezon.com>

Email: flezon@flezon.com

1. ELECTRICAL SPECIFICATIONS



Model No.: 58PA34120ULFLA

Description PZ TRANSDUCER 3V L/W ABS S. STEEL RoHS

<i>MODEL NO.</i>	58PA34120ULFLA
<i>SOUND PRESSURE LEVEL</i>	70.0 dBA min. (3.0 V rms Sine Wave , 10 cm , 1200 Hz)
<i>CAPACITANCE</i>	50000 pF ± 30 % at 120Hz
* <i>MAX. INPUT VOLTAGE</i>	30.0 V p-p
<i>OPERATING TEMPERATURE</i>	-20 ~ +70 ° C
<i>TERMINAL</i>	LEADWIRE (UL1007 , AWG#30)
<i>HOUSING MATERIAL</i>	ABS
* <i>WEIGHT</i>	6.0 g

FLEZON CONFIDENTIAL

2. PHYSICAL DIMENSION



All dimensions stated are in mm

Tolerance: ± 0.5 mm

SIDE VIEW

TOP VIEW

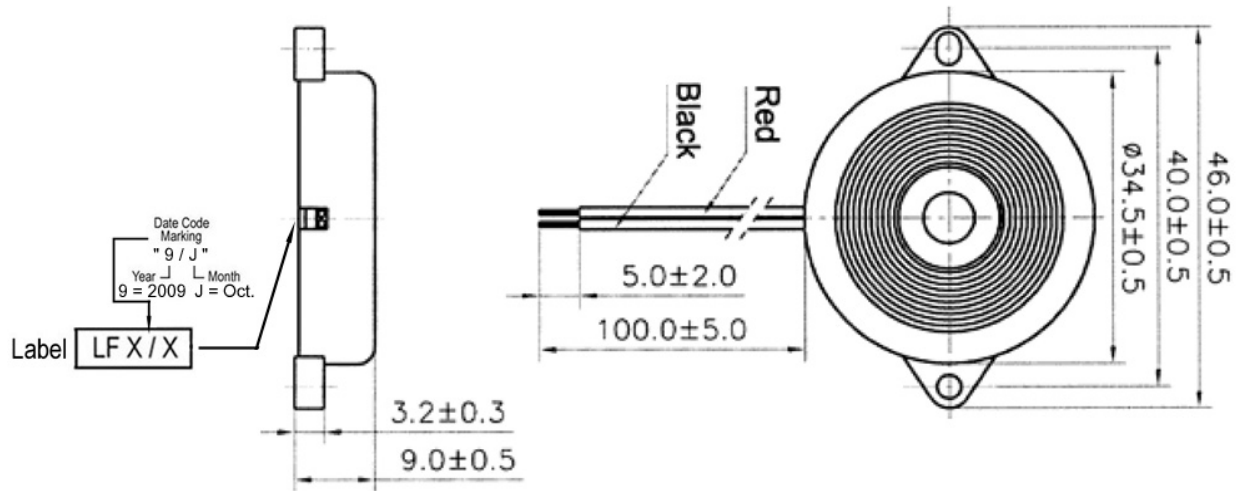

FLEZON CC

Revision History

Revision	Date	Description
1.0	2009/10	First release

FLEZON CONFIDENTIAL