



External Drive Piezo Transducer Specification

Series FZ-V678

Model Number: 67PA17400LFQLA

Version 1.0

Address: 28 Genting Lane, #08-07 Platinum 28, Singapore 349585

Tel: +65-6493 5035

Fax: +65-6493 5037

Website: <http://www.flezon.com>

Email: flezon@flezon.com

1. ELECTRICAL SPECIFICATIONS



Model No.: 67PA17400LFQLA

Description PZ TRANSDUCER 9V L/W ABS SP RoHS

<i>MODEL NO.</i>	67PA17400LFQLA
<i>SOUND PRESSURE LEVEL</i>	80.0 dBA min. (9.0V p-p Square Wave , 10 cm , 4000 Hz)
<i>CAPACITANCE</i>	9500 pF ± 30 % at 120 Hz
* <i>MAX. INPUT VOLTAGE</i>	25.0 V p-p
<i>OPERATING TEMPERATURE</i>	-20 ~ +60 ° C
<i>TERMINAL</i>	LEADWIRE
<i>HOUSING MATERIAL</i>	ABS
* <i>WEIGHT</i>	1.0 g

FLEZON CONFIDENTIAL

2. PHYSICAL DIMENSION



All dimensions stated are in mm

Tolerance: $\pm 0.5\text{mm}$

TOP VIEW

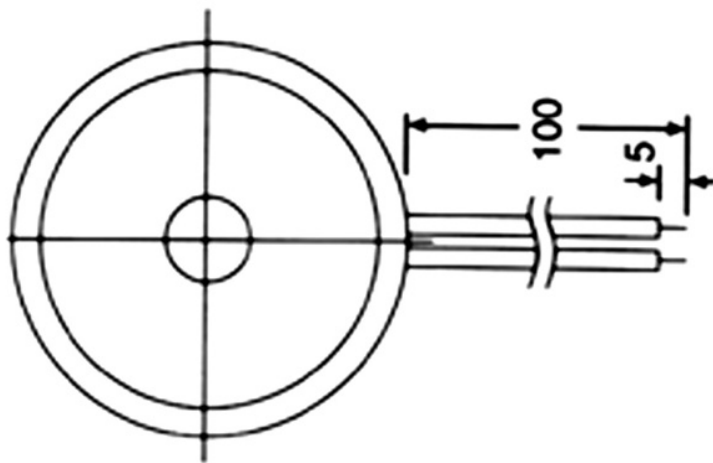

SIDE VIEW

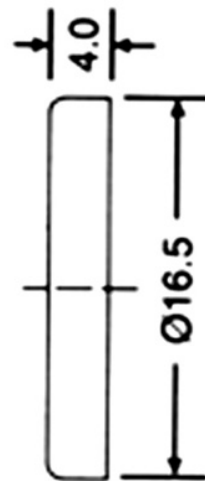

FLEZON

Revision History

Revision	Date	Description
1.0	2005/03	First release

FLEZON CONFIDENTIAL