



External Drive Piezo Transducer Specification

Series FET

Model Number: FET12S03N03DMPA

Version 1.0

Address: 28 Genting Lane, #08-07 Platinum 28, Singapore 349585

Tel: +65-6493 5035

Fax: +65-6493 5037

Website: <http://www.flezon.com>

Email: flezon@flezon.com

1. ELECTRICAL SPECIFICATIONS



Model No.: FET12S03N03DMPA

Description: PZ TRANSDUCER 3V SMD LCP RoHS SP (BLACK)

1) OPERATING TEMPERATURE -40 ~ +105 °C

2) STORAGE TEMPERATURE -40 ~ +105 °C

MODEL NO.	<u>FET12S03N03DMPA</u>
<i>SOUND PRESSURE LEVEL</i>	75.0 dBA Min. (3.0 Vp-p Square Wave , 10cm ,4000 Hz)
<i>CAPACITANCE</i>	16000 pF ± 30 % at 120 Hz
* <i>MAX. INPUT VOLTAGE</i>	25.0 V p-p
<i>OPERATING TEMPERATURE</i>	-40.0 ~ +105.0 ° C
<i>STORAGE TEMPERATURE</i>	-40.0 ~ +105.0 ° C
<i>TERMINAL</i>	SMD
<i>HOUSING MATERIAL</i>	LCP
* <i>WEIGHT</i>	0.3 g

FLEZON CONFIDENTIAL

2. PHYSICAL DIMENSION



All dimensions stated are in mm

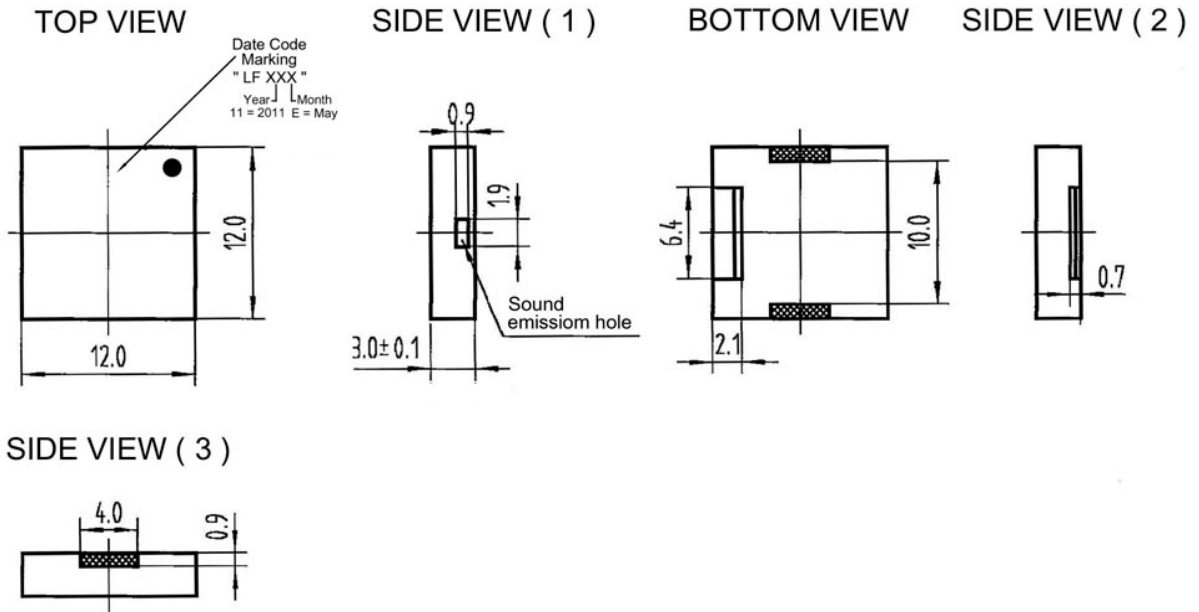

FLEZON CO.

Revision History

Revision	Date	Description
1.0	2012.05	First Released

FLEZON CONFIDENTIAL