



# External Drive Piezo Transducer Specification

## Series FET

Model Number: FET17C05N03DMPN

Version 1.0

Address: 28 Genting Lane, #08-07 Platinum 28, Singapore 349585

Tel: +65-6493 5035

Fax: +65-6493 5037

Website: <http://www.flezon.com>

Email: [flezon@flezon.com](mailto:flezon@flezon.com)

# 1. ELECTRICAL SPECIFICATIONS



**Model No.:** FET17C05N03DMPN

**Description** PZ TRANSDUCER 3V SMD LCP SP 1) Min. 85dBA 2) RoHS (BLACK)

<i>MODEL NO.</i>	<b><u>FET17C05N03DMPN</u></b>
<i>SOUND PRESSURE LEVEL</i>	85 dBA min. ( 3.0 V rms Sine Wave , 10 cm , 4000 Hz )
<i>CAPACITANCE</i>	10000 pF ± 30 % at 120 Hz
* <i>MAX. INPUT VOLTAGE</i>	30 V p-p
<i>OPERATING TEMPERATURE</i>	-20 ~ +70 ° C
<i>TERMINAL</i>	SMD
<i>HOUSING MATERIAL</i>	LCP
* <i>WEIGHT</i>	3.0 g

FLEZON CONFIDENTIAL

## 2. PHYSICAL DIMENSION



All dimensions stated are in mm

### TOP VIEW

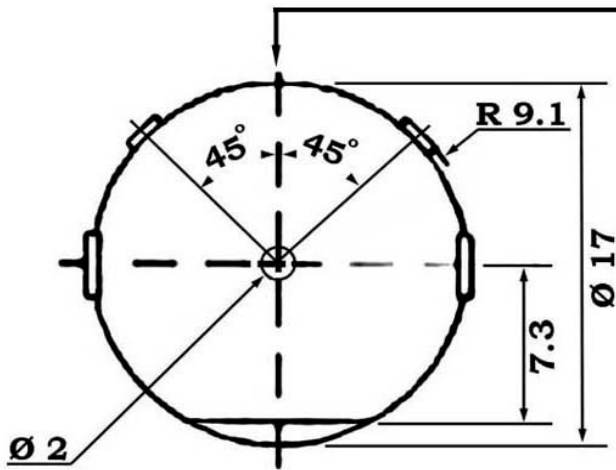

### SIDE VIEW

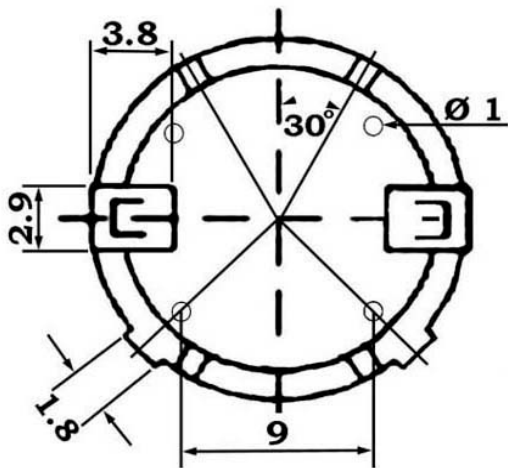
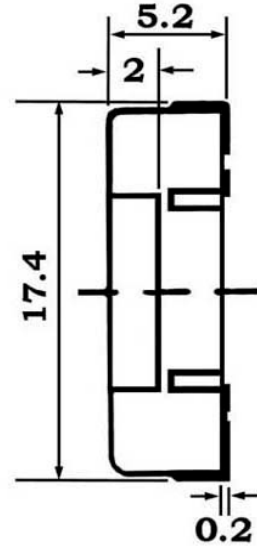

### BOTTOM VIEW

Label

LF X / X

Date Code  
Marking

" 5 K "

Year | Month  
5 = 2005 | K = Nov.

## Revision History

Revision	Date	Description
1.0	2008.09	First Released

FLEZON CONFIDENTIAL