



# Magnetic Transducer Specification

## Series FZ108

Model Number: FZ108LFPN

Version 1.0

Address: 28 Genting Lane, #08-07 Platinum 28, Singapore 349585

Tel: +65-6493 5035

Fax: +65-6493 5037

Website: <http://www.flezon.com>

Email: [flezon@flezon.com](mailto:flezon@flezon.com)

# 1. ELECTRICAL SPECIFICATIONS



**Model No.:** FZ108LFPN

**Description:** MT TRANSDUCER 3V PIN NORYL RoHS

<i>MODEL NO.</i>	<u>FZ108LFPN</u>
<i>OPERATING VOLTAGE RANGE ( V )</i>	1.0 ~ 4.0
<i>RATED VOLTAGE ( V )</i>	3.0
+ <i>MAX. RATED CURRENT ( mA )</i>	35.0
<i>COIL RESISTANCE ( Ω )</i>	15.0 ± 6.0
* <i>COIL IMPEDANCE ( Ω )</i>	60.0
+ <i>MIN. SOUND OUTPUT at 10cm ( dBA )</i>	85.0
<i>RESONANT FREQUENCY ( Hz )</i>	2000
<i>OPERATING TEMPERATURE ( °C )</i>	- 20 ~ + 60
<i>TERMINAL</i>	PIN
<i>HOUSING MATERIAL</i>	NORYL
<i>WEIGHT ( g )</i>	2.0

+ Value applying rated voltage resonant frequency, 1/2 duty, square wave

\* Value applying resonant frequency, 1/2 duty, square wave, measuring current 60uA

## 2. PHYSICAL DIMENSION



All dimensions stated are in mm

Tolerance:  $\pm 0.2\text{mm}$

### TOP VIEW

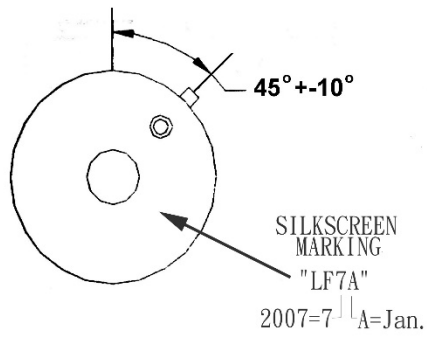

### SIDE VIEW

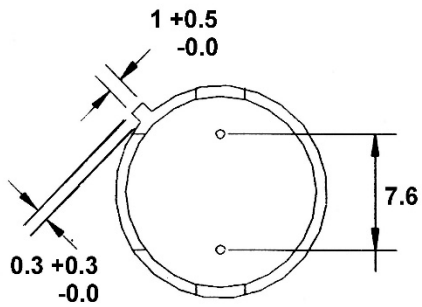
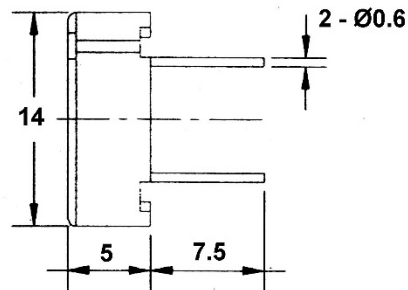

### BOTTOM VIEW

## Revision History

Revision	Date	Description
1.0	2007/01	First release

FLEZON CONFIDENTIAL