



Magnetic Transducer Specification

Series FZ110

Model Number: FZ110LFPN

Version 2.0

Address: 28 Genting Lane, #08-07 Platinum 28, Singapore 349585

Tel: +65-6493 5035

Fax: +65-6493 5037

Website: <http://www.flezon.com>

Email: flezon@flezon.com

1. ELECTRICAL SPECIFICATIONS



Model No.: FZ110LFPN

Description: MY TRANSDUER 1.5V PIN NORYL RoHS

<i>MODEL NO.</i>	<u>FZ110LFPN</u>
<i>OPERATING VOLTAGE RANGE (V)</i>	1.0 ~ 4.0
<i>RATED VOLTAGE (V)</i>	1.5
+ <i>MAX. RATED CURRENT (mA)</i>	80
<i>COIL RESISTANCE (Ω)</i>	8 \pm 1
+ <i>MIN. SOUND OUTPUT at 10cm (dBA)</i>	70
<i>RESONANT FREQUENCY (Hz)</i>	2730
<i>OPERATING TEMPERATURE ($^{\circ}$ C)</i>	-20 ~ +80
<i>TERMINAL</i>	PIN
<i>HOUSING MATERIAL</i>	NORYL
<i>WEIGHT (g)</i>	1.0

+ Value applying rated voltage resonant frequency,1/2 duty , square wave

* Value applying resonant frequency,1/2 duty , square wave ,measuring current 60uA

2. PHYSICAL DIMENSION



All dimensions stated are in mm

Tolerance: $\pm 0.2\text{mm}$

TOP VIEW

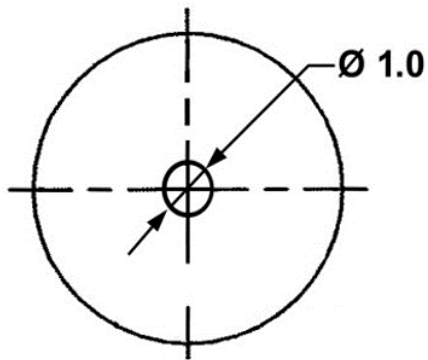

SIDE VIEW

Silk Screen
Marking
FZ110LFPN
6L

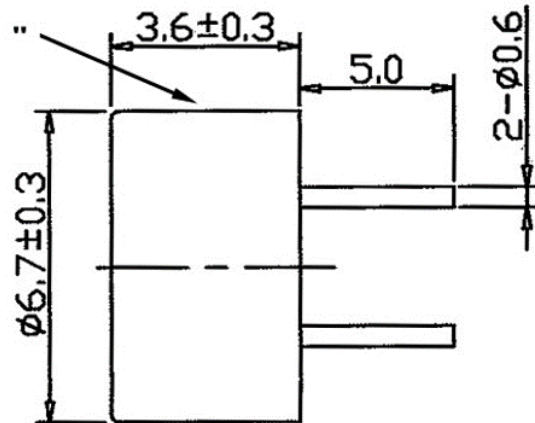

BOTTOM VIEW

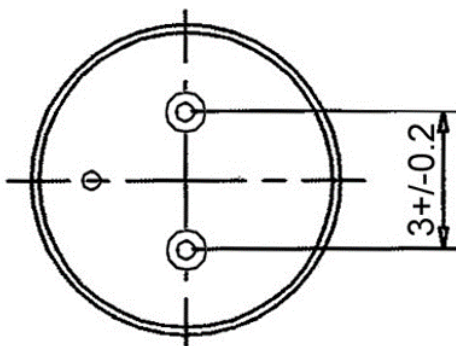

Revision History

Revision	Date	Description
1.0		First release
2.0	2009/07	Modify the operating voltage

FLEZON CONFIDENTIAL