



Magnetic Transducer Specification

Series FZ113

Model Number: FZ113LFPN

Version 2.0

Address: 28 Genting Lane, #08-07 Platinum 28, Singapore 349585

Tel: +65-6493 5035

Fax: +65-6493 5037

Website: <http://www.flezon.com>

Email: flezon@flezon.com

1. ELECTRICAL SPECIFICATIONS



Model No.: FZ113LFPN

Description: MT TRANSDUCER 1.5V PIN NORYL RoHS

<i>MODEL NO.</i>	<u>FZ113LFPN</u>
<i>OPERATING VOLTAGE RANGE (V)</i>	1.0 ~ 2.0
<i>RATED VOLTAGE (V)</i>	1.5
+ <i>MAX. RATED CURRENT (mA)</i>	30.0
<i>COIL RESISTANCE (Ω)</i>	16.0 ± 4.5
+ <i>MIN. SOUND OUTPUT at 10cm (dBA)</i>	80.0
<i>RESONANT FREQUENCY (Hz)</i>	2048
<i>OPERATING TEMPERATURE (° C)</i>	- 20.0 ~ + 60.0
<i>STORAGE TEMPERATURE (° C)</i>	- 30.0 ~ + 70.0
<i>TERMINAL</i>	PIN
<i>HOUSING MATERIAL</i>	NORYL
<i>WEIGHT (g)</i>	2.0

+ Value applying rated voltage resonant frequency, 1/2 duty, square wave

* Value applying resonant frequency, 1/2 duty, square wave, measuring current 60uA

2. PHYSICAL DIMENSION



All dimensions stated are in mm

Tolerance: $\pm 0.2\text{mm}$

TOP VIEW

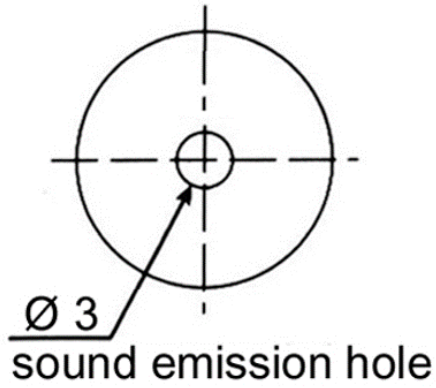

SIDE VIEW

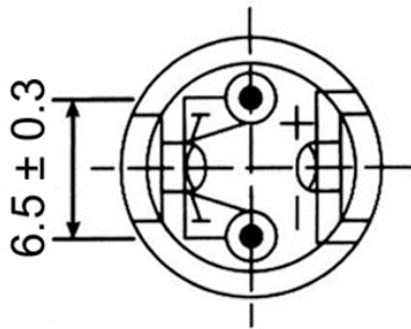
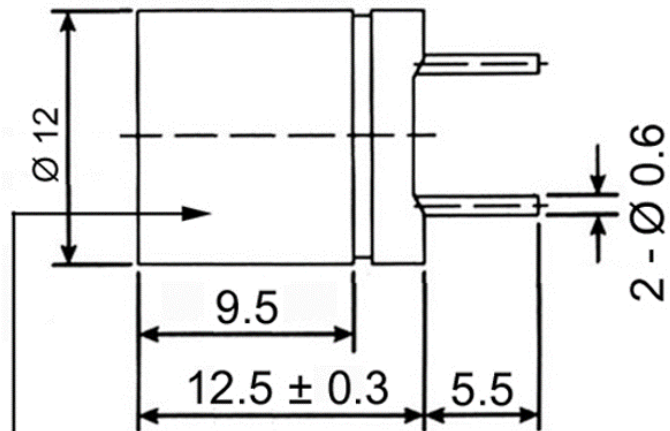

BOTTOM VIEW

Marking
" FZ113LFPN "

XX X

Date Code
Marking
" 14 G "

Year	└	└	Month
14 = 2014			G = Jul.

Revision History

Revision	Date	Description
1.0		First release
2.0	2014/07	Height 13 mm change to 12.5 mm

FLEZON CONFIDENTIAL