



Mylar Speaker Specification

Series N201A

Model Number: N201A080008LFSM

Version 1.0

Address: 28 Genting Lane, #08-07 Platinum 28, Singapore 349585

Tel: +65-6493 5035

Fax: +65-6493 5037

Website: <http://www.flezon.com>

Email: flezon@flezon.com

ALL RIGHTS ARE STRICTLY RESERVED. ANY PORTION OF THIS PAPER SHALL NOT BE REPRODUCED, COPIED, OR TRANSLATED TO ANY OTHER FORMS WITHOUT PERMISSION FROM FLEXXON GLOBAL LIMITED.



1. ELECTRICAL SPECIFICATIONS



Model No.: N20IA080008LFSM

Description: MY 20D 3H 11B 80hm F0 = 800Hz SP RoHS

MODEL NO.	N20IA080008LFSM	
SHAPE	ROUND	
MAGNET (N35)	mm	Ø 8.0 X 1.0
DIAMETER (D ± 0.2)	mm	Ø 20.0
HEIGHT (H ± 0.3)	mm	3.0
BACK DIA.(D ± 0.2)	mm	Ø 11.0
R. FREQUENCY ± 20 %	Hz	800
RESPONSE FREQ. F0 TO	Hz	20.0 K
RATED POWER	W	0.3
MAX POWER	W	0.5
OUTPUT (dB / 1 W (1 m) AVE 0.8K,1.0K,1.2K,1.5K(Hz)	dB	80.0 ± 3.0
STANDARD IMPEDANCE ± 15 % AT 1V	Ω	8.0
TERMINAL	NIL	
BUZZER & RATTLES	1.55 V SINE WAVE	
DISTORTION	5.0% Max. (0.3 W , 1.0 K Hz)	
OPERATING TEMPERATURE	°C	- 20.0 ~ + 55.0
HOUSING MATERIAL	METAL	
DIAPHRAGM MATERIAL	MYLAR	
WEIGHT	g	2.4 g

2. PHYSICAL DIMENSION



All dimensions stated are in mm

BOTTOM VIEW

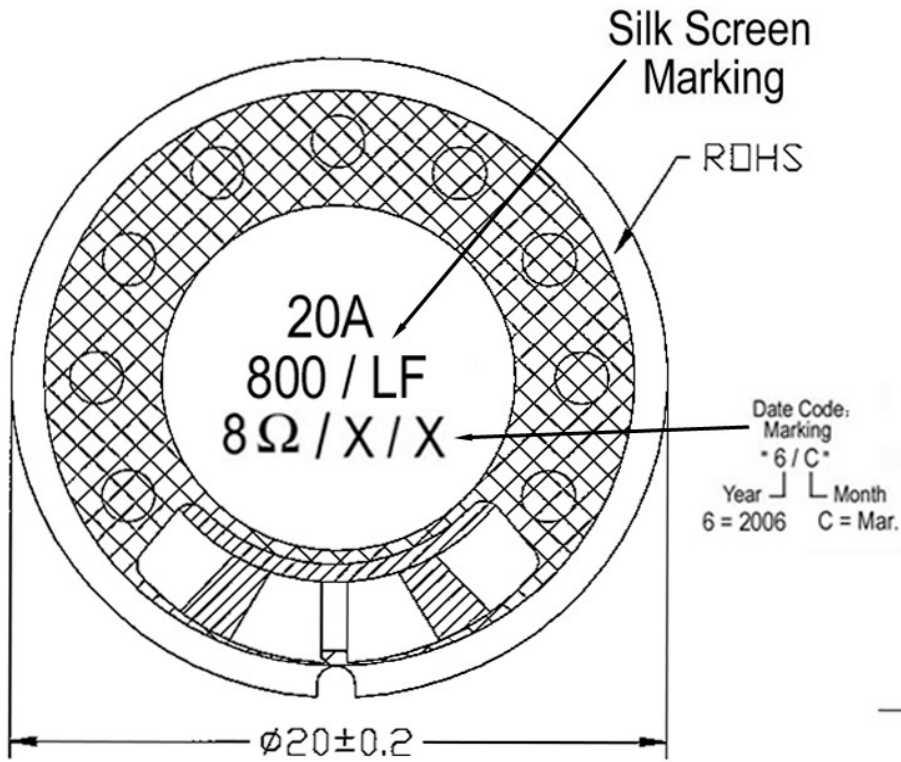

SIDE VIEW

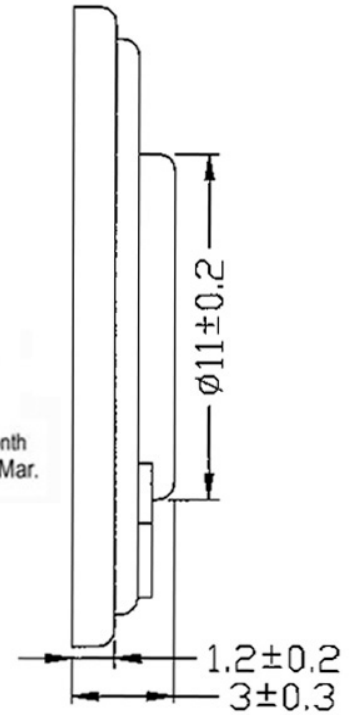

FLEZON

Revision History

Revision	Date	Description
1.0	2006.03	First Released

FLEZON CONFIDENTIAL