

# 0402 AQC

Engineer's Kit : EK-0402AQC-X

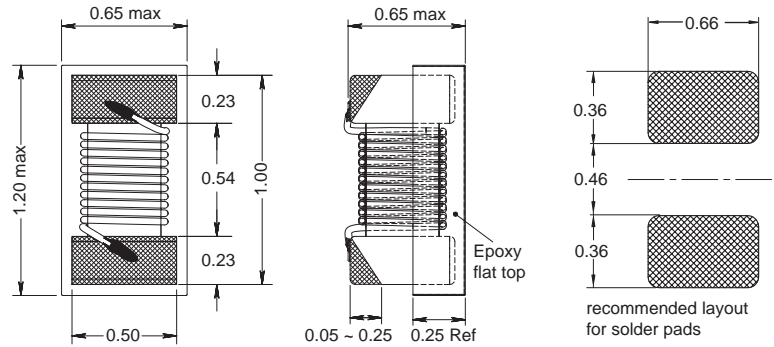
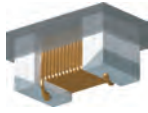

Wire wound - open

Chip Inductors for RF Applications

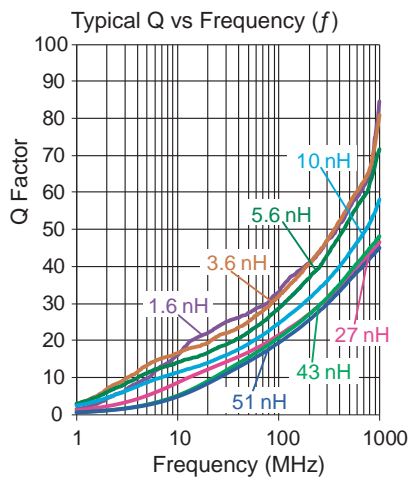
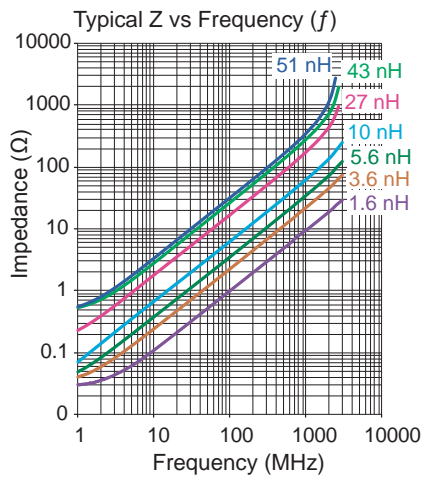
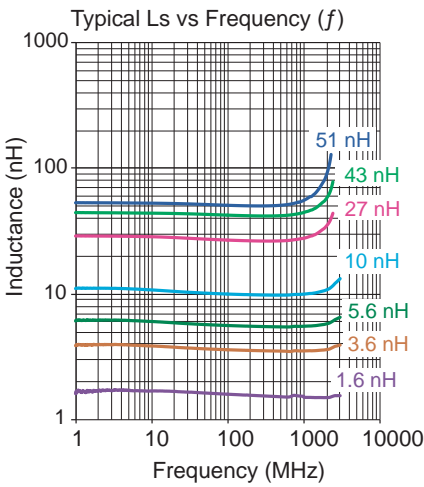

Single layer (typ)

Part No	Inductance L (nH)	f <sub>L</sub> (MHz)	Tol ± (%)	Q min	f <sub>Q</sub> (MHz)	SRF typ (GHz)	DCR max (Ω)	Rated DC Current (A)
0402AQC-0N9M-YY	0.9	100	20	24	250	18	0.015	3.00
0402AQC-1N6K-YY	1.6	100	10	24	250	18	0.040	2.00
0402AQC-1N7K-YY	1.7	100	10	24	250	18	0.040	2.00
0402AQC-2N8K-YY	2.8	100	10	27	250	13.5	0.040	2.00
0402AQC-2N9K-YY	2.9	100	10	27	250	12.5	0.040	2.00
0402AQC-3N0K-YY	3.0	100	10	30	250	12.5	0.040	2.00
0402AQC-3N3K-YY	3.3	100	10	30	250	14.0	0.040	2.00
0402AQC-3N4K-YY	3.4	100	10	30	250	10.0	0.040	2.00
0402AQC-3N5K-YY	3.5	100	10	30	250	10.0	0.040	2.00
0402AQC-3N6K-YY	3.6	100	10	30	250	10.0	0.040	2.00
0402AQC-3N7K-YY	3.7	100	10	32	250	10.0	0.040	2.00
0402AQC-3N8K-YY	3.8	100	10	32	250	10.0	0.040	2.00
0402AQC-3N9K-YY	3.9	100	10	32	250	10.0	0.040	2.00
0402AQC-4N0K-YY	4.0	100	10	32	250	10.0	0.040	1.80
0402AQC-4N1K-YY	4.1	100	10	32	250	9.60	0.040	1.80
0402AQC-4N2K-YY	4.2	100	10	32	250	9.60	0.060	1.80
0402AQC-4N3K-YY	4.3	100	10	32	250	9.60	0.060	1.80
0402AQC-4N4K-YY	4.4	100	10	32	250	9.60	0.050	1.85
0402AQC-4N5K-YY	4.5	100	10	32	250	9.60	0.050	1.85
0402AQC-4N6K-YY	4.6	100	10	31	250	9.60	0.050	1.85
0402AQC-4N7K-YY	4.7	100	10	31	250	8.00	0.050	1.85
0402AQC-4N8K-YY	4.8	100	10	31	250	8.00	0.050	1.85
0402AQC-4N9K-YY	4.9	100	10	31	250	8.00	0.050	1.85
0402AQC-5N0K-YY	5.0	100	10	31	250	8.00	0.050	1.85
0402AQC-5N1K-YY	5.1	100	10	31	250	8.00	0.050	1.85
0402AQC-5N2K-YY	5.2	100	10	31	250	8.00	0.050	1.85
0402AQC-5N3K-YY	5.3	100	10	31	250	8.00	0.050	1.85
0402AQC-5N4K-YY	5.4	100	10	31	250	8.00	0.050	1.85
0402AQC-5N5K-YY	5.5	100	10	31	250	8.00	0.050	1.85
0402AQC-5N6K-YY	5.6	100	10	31	250	8.00	0.050	1.85
0402AQC-5N7K-YY	5.7	100	10	31	250	8.00	0.050	1.85
0402AQC-5N8K-YY	5.8	100	10	31	250	8.00	0.050	1.85
0402AQC-5N9K-YY	5.9	100	10	31	250	8.00	0.050	1.85
0402AQC-6N0K-YY	6.0	100	10	31	250	8.00	0.050	1.80
0402AQC-6N1K-YY	6.1	100	10	31	250	8.00	0.050	1.80
0402AQC-6N2K-YY	6.2	100	10	31	250	8.00	0.050	1.80
0402AQC-6N3K-YY	6.3	100	10	31	250	7.80	0.050	1.70
0402AQC-6N4K-YY	6.4	100	10	31	250	7.00	0.065	1.70
0402AQC-6N5K-YY	6.5	100	10	28	250	7.00	0.070	1.70
0402AQC-6N6J-YY	6.6	100	5	28	250	7.00	0.065	1.70
0402AQC-6N7J-YY	6.7	100	5	30	250	7.00	0.065	1.70
0402AQC-6N8J-YY	6.8	100	5	30	250	7.00	0.065	1.70
0402AQC-6N9J-YY	6.9	100	5	31	250	7.00	0.065	1.70
0402AQC-7N0J-YY	7.0	100	5	31	250	7.00	0.065	1.70
0402AQC-7N1J-YY	7.1	100	5	31	250	7.00	0.065	1.70
0402AQC-7N2J-YY	7.2	100	5	31	250	7.00	0.065	1.70
0402AQC-7N3J-YY	7.3	100	5	31	250	7.00	0.065	1.70
0402AQC-7N4J-YY	7.4	100	5	31	250	7.00	0.065	1.70

• All dimensions in mm

(Wire wound - open)

Chip Inductors for RF Applications

Part No	Inductance	f <sub>L</sub>	Tol	Q	f <sub>α</sub>	SRF	DCR	Rated DC
	L (nH)	(MHz)	± (%)	min	(MHz)	typ (GHz)	max (Ω)	Current (A)
0402AQC-7N5J-YY	7.5	100	5	31	250	7.00	0.065	1.70
0402AQC-7N6J-YY	7.6	100	5	31	250	7.00	0.065	1.70
0402AQC-7N7J-YY	7.7	100	5	31	250	7.00	0.065	1.70
0402AQC-7N8J-YY	7.8	100	5	31	250	7.00	0.065	1.70
0402AQC-7N9J-YY	7.9	100	5	31	250	7.00	0.065	1.70
0402AQC-8N1J-YY	8.1	100	5	31	250	6.50	0.065	1.70
0402AQC-8N2J-YY	8.2	100	5	30	250	6.50	0.065	1.65
0402AQC-8N3J-YY	8.3	100	5	30	250	6.50	0.065	1.65
0402AQC-8N4J-YY	8.4	100	5	30	250	6.50	0.070	1.60
0402AQC-8N5J-YY	8.5	100	5	30	250	6.50	0.070	1.60
0402AQC-8N6J-YY	8.6	100	5	30	250	6.50	0.070	1.60
0402AQC-8N7J-YY	8.7	100	5	30	250	6.50	0.070	1.50
0402AQC-8N8J-YY	8.8	100	5	30	250	6.50	0.070	1.50
0402AQC-8N9J-YY	8.9	100	5	30	250	6.50	0.070	1.50
0402AQC-9N0J-YY	9.0	100	5	30	250	6.50	0.078	1.50
0402AQC-9N1J-YY	9.1	100	5	30	250	6.50	0.078	1.50
0402AQC-9N2J-YY	9.2	100	5	30	250	6.00	0.078	1.50
0402AQC-9N3J-YY	9.3	100	5	30	250	6.00	0.080	1.50
0402AQC-9N4J-YY	9.4	100	5	30	250	6.00	0.080	1.50
0402AQC-9N5J-YY	9.5	100	5	30	250	6.00	0.080	1.50
0402AQC-9N6J-YY	9.6	100	5	30	250	6.00	0.080	1.50
0402AQC-9N7J-YY	9.7	100	5	30	250	6.00	0.080	1.50
0402AQC-9N8J-YY	9.8	100	5	30	250	6.00	0.080	1.50
0402AQC-9N9J-YY	9.9	100	5	30	250	6.00	0.080	1.50
0402AQC-010J-YY	10	100	5	30	250	6.00	0.080	1.50
0402AQC-011J-YY	11	100	5	30	250	6.00	0.080	1.50
0402AQC-012J-YY	12	100	5	30	250	5.20	0.095	1.35
0402AQC-013J-YY	13	100	5	30	250	5.20	0.095	1.35
0402AQC-014J-YY	14	100	5	28	250	5.20	0.110	1.20
0402AQC-015J-YY	15	100	5	28	250	5.50	0.120	1.15
0402AQC-016J-YY	16	100	5	26	250	5.00	0.140	1.10
0402AQC-017J-YY	17	100	5	26	250	5.00	0.140	1.10
0402AQC-018J-YY	18	100	5	26	250	5.00	0.140	1.10
0402AQC-019J-YY	19	100	5	26	250	5.00	0.140	1.10
0402AQC-020J-YY	20	100	5	26	250	4.50	0.225	0.80
0402AQC-021J-YY	21	100	5	26	250	4.50	0.225	0.80
0402AQC-022J-YY	22	100	5	25	250	4.50	0.225	0.80
0402AQC-023J-YY	23	100	5	25	250	4.50	0.225	0.80
0402AQC-024J-YY	24	100	5	25	250	4.00	0.225	0.80
0402AQC-025J-YY	25	100	5	25	250	4.00	0.255	0.80
0402AQC-026J-YY	26	100	5	25	250	4.00	0.270	0.80
0402AQC-027J-YY	27	100	5	25	250	4.00	0.270	0.80
0402AQC-030J-YY	30	100	5	25	250	3.80	0.290	0.70
0402AQC-033J-YY	33	100	5	25	250	3.60	0.345	0.65
0402AQC-036J-YY	36	100	5	25	250	3.50	0.455	0.60
0402AQC-039J-YY	39	100	5	25	250	3.40	0.455	0.60
0402AQC-043J-YY	43	100	5	25	250	3.40	0.585	0.45
0402AQC-047J-YY	47	100	5	25	250	3.20	0.600	0.45
0402AQC-051J-YY	51	100	5	25	250	2.90	0.690	0.45

Core Material : Ceramic

Revision date : 28 Oct 2020

SPQ : Taped / Reel 1000 [-08]  
5000 [-01]

Remarks: - Unlisted inductance values available upon request.  
- 3% and 5% tolerance available upon request.