

0805 AQ

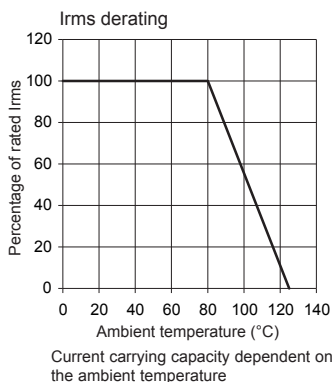

High Q

Engineer's Kit : EK-0805AQ-X

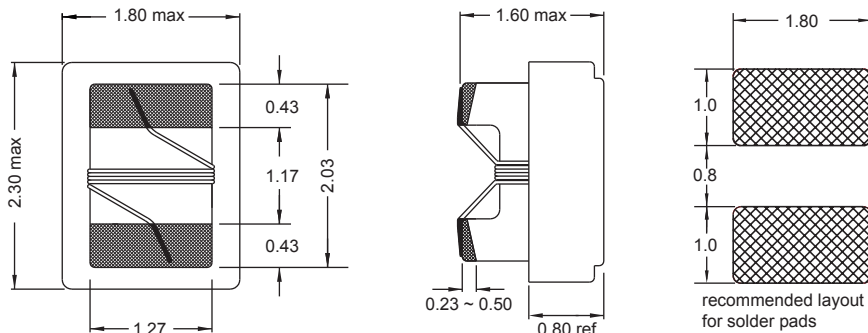
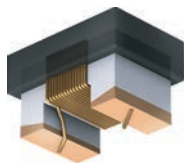

Single layer (typ)

Part No	Inductance L (nH)	f _L (MHz)	Tol ± (%)	Q min	f _Q (MHz)	SRF min (MHz)	DCR max (Ω)	Rated DC Current (mA)
0805AQ-2N5K-YY	2.5	250	10	80	1500	>6000	0.020	1600
0805AQ-2N7K-YY	2.7	250	10	67	1500	>6000	0.020	1600
0805AQ-5N6K-YY	5.6	250	10	98	1500	>6000	0.035	1600
0805AQ-6N2K-YY	6.2	250	10	88	1000	4750	0.035	1600
0805AQ-8N7K-YY	8.7	250	10	50	1000	5300	0.045	1600
0805AQ-011J-YY	11	250	5	83	1000	3000	0.060	1600
0805AQ-012J-YY	12	250	5	80	1000	3000	0.045	1600
0805AQ-015J-YY	15	250	5	78	500	2950	0.060	1500
0805AQ-016J-YY	16	250	5	78	500	2950	0.060	1500
0805AQ-018J-YY	18	250	5	76	500	2550	0.060	1400
0805AQ-020J-YY	20	250	5	74	500	2050	0.055	1400
0805AQ-022J-YY	22	250	5	60	500	2050	0.070	1400
0805AQ-027J-YY	27	250	5	75	500	2000	0.070	1300
0805AQ-030J-YY	30	250	5	69	500	1950	0.095	1200
0805AQ-039J-YY	39	250	5	74	500	1600	0.110	1100
0805AQ-047J-YY	47	200	5	85	500	1400	0.095	1200
0805AQ-048J-YY	48	200	5	71	500	1400	0.095	1200
0805AQ-051J-YY	51	200	5	65	500	1400	0.120	1000
0805AQ-056J-YY	56	200	5	75	500	1400	0.120	1000

Core Material : Ceramic

Revision date : 11 Aug 2014

SPQ : Taped / Reel 2500 [-01]
7500 [-04]

Remarks: - For not listed inductance values please check availability with us.
- 2% and 5% tolerance available on request.

