



**Modulelink(Shenzhen) Technology Co., Ltd.**

[Http://www.modulelink.net](http://www.modulelink.net)

Optical network solutions provider

## **SFP 155M Transceiver MSFP-155M-BIDI20**

### **PRODUCT FEATURES**

- Up to 155Mb/s data links
- 1310nm Fabry-Perot laser transmitter
- Up to 20km on 9/125µm SMF
- Hot-pluggable SFP footprint
- BIDI LC/UPC type pluggable optical interface
- Low power dissipation
- Metal enclosure, for lower EMI
- RoHS compliant and lead-free
- Single +3.3V power supply
- Compliant with SFF-8472
- Operating case temperature: 0°C to +70°C

### **APPLICATIONS**

- Switch to Switch Interface
- Fast Ethernet
- Switched Backplane Applications
- Router/Server Interface
- Other Optical Links

### **PRODUCT DESCRIPTION**

Modulelink's MSFP-155M-BIDI20 Small Form Factor Pluggable (SFP) transceivers are compatible with the Small Form Factor Pluggable Multi-Sourcing Agreement (MSA). The transceiver consists of four sections: the LD driver, the limiting amplifier, the 1310nm FP laser and the PIN photo-detector. The module data link up to 20KM in 9/125um single mode fiber.

The optical output can be disabled by a TTL logic high-level input of Tx Disable, and the system also can disable the module via I2C. Tx Fault is provided to indicate that degradation of the laser. Loss of signal(LOS)

---

Add: 3rd floor Block 2, Tianlong Science Industry Park, Kengzhi Town, Longgang Area, Shenzhen, China.

Tel: 86-755-86101649

Fax: 86-755-86101640

Dec 10 / 2011

E-mail:sales@modulelink.net

Website: www.modulelink.net

Rev.1.3



## Modulelink(Shenzhen) Technology Co., Ltd.

[Http://www.modulelink.net](http://www.modulelink.net)

Optical network solutions provider

output is provided to indicate the loss of an input optical signal of receiver or the link status with partner. The system can also get the LOS(or Link)/Disable/Fault information via I2C register access.

### Pin Descriptions

Pin	Symbol	Name/Description	Ref.
1	V <sub>EET</sub>	Transmitter Ground (Common with Receiver Ground)	1
2	T <sub>FAULT</sub>	Transmitter Fault. Not supported.	
3	T <sub>DIS</sub>	Transmitter Disable. Laser output disabled on high or open.	2
4	MOD_DEF(2)	Module Definition 2. Data line for Serial ID.	3
5	MOD_DEF(1)	Module Definition 1. Clock line for Serial ID.	3
6	MOD_DEF(0)	Module Definition 0. Grounded within the module.	3
7	Rate Select	No connection required	4
8	LOS	Loss of Signal indication. Logic 0 indicates normal operation.	5
9	V <sub>EER</sub>	Receiver Ground (Common with Transmitter Ground)	1
10	V <sub>EER</sub>	Receiver Ground (Common with Transmitter Ground)	1
11	V <sub>EER</sub>	Receiver Ground (Common with Transmitter Ground)	1
12	RD-	Receiver Inverted DATA out. AC Coupled	
13	RD+	Receiver Non-inverted DATA out. AC Coupled	
14	V <sub>EER</sub>	Receiver Ground (Common with Transmitter Ground)	1
15	V <sub>CCR</sub>	Receiver Power Supply	
16	V <sub>CCT</sub>	Transmitter Power Supply	
17	V <sub>EET</sub>	Transmitter Ground (Common with Receiver Ground)	1
18	TD+	Transmitter Non-Inverted DATA in. AC Coupled.	
19	TD-	Transmitter Inverted DATA in. AC Coupled.	
20	V <sub>EET</sub>	Transmitter Ground (Common with Receiver Ground)	1

#### Notes:

1. Circuit ground is internally isolated from chassis ground.
2. Laser output disabled on T<sub>DIS</sub> >2.0V or open, enabled on T<sub>DIS</sub> <0.8V.
3. Should be pulled up with 4.7k - 10kohms on host board to a voltage between 2.0V and 3.6V.  
MOD\_DEF(0) pulls line low to indicate module is plugged in.

Add: 3rd floor Block 2, Tianlong Science Industry Park, Kengzhi Town, Longgang Area, Shenzhen, China.

Tel: 86-755-86101649

Fax: 86-755-86101640

Dec 10 / 2011

E-mail:sales@modulelink.net

Website: www.modulelink.net

Rev.1.3



## Modulelink(Shenzhen) Technology Co., Ltd.

[Http://www.modulelink.net](http://www.modulelink.net)

Optical network solutions provider

4. This is an optional input used to control the receiver bandwidth for compatibility with multiple data rates (most likely Fibre Channel 1x and 2x Rates). If implemented, the input will be internally pulled down with > 30kΩ resistor. The input states are:

Low (0 – 0.8V): Reduced Bandwidth

(>0.8 , < 2.0V): Undefined

High (2.0 – 3.465V): Full Bandwidth

Open: Reduced Bandwidth

5. LOS is open collector output. Should be pulled up with 4.7k - 10kohms on host board to a voltage between 2.0V and 3.6V. Logic 0 indicates normal operation; logic 1 indicates loss of signal.

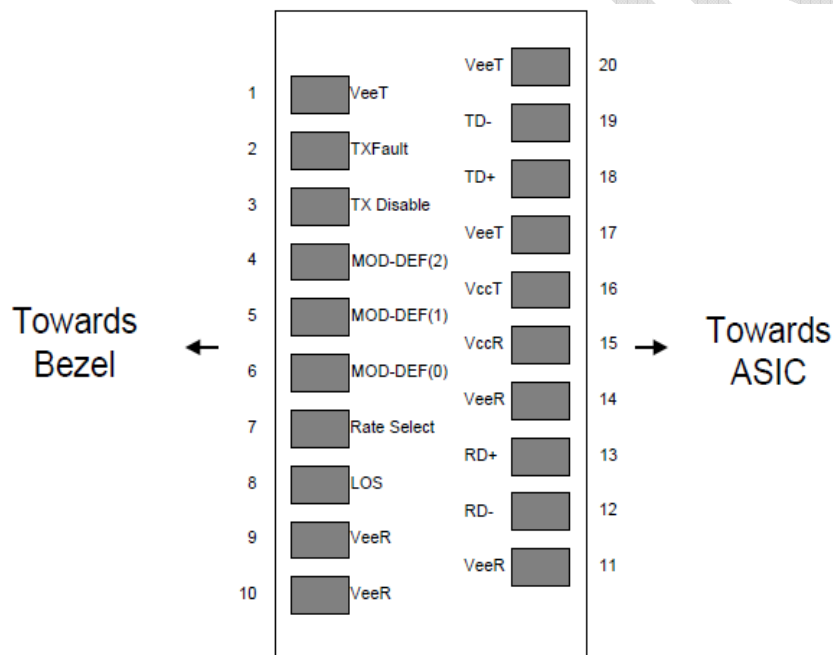

Figure 2. Pinout of Connector Block on Host Board

Add: 3rd floor Block 2, Tianlong Science Industry Park, Kengzhi Town, Longgang Area, Shenzhen, China.

Tel: 86-755-86101649

Fax: 86-755-86101640

Dec 10 / 2011

E-mail: sales@modulelink.net

Website: www.modulelink.net

Rev.1.3



## Modulelink(Shenzhen) Technology Co., Ltd.

Http://www.modulelink.net

Optical network solutions provider

### Absolute Maximum Ratings

Parameter	Symbol	Min.	Typ.	Max.	Unit	Note
Storage Temperature	T <sub>s</sub>	-40		85	°C	
Storage Ambient Humidity	HA	5		95	%	
Power Supply Voltage	V <sub>CC</sub>	-0.5		4	V	
Signal Input Voltage		-0.3		V <sub>CC</sub> +0.3	V	
Receiver Damage Threshold		+4			dBm	
Lead Soldering Temperature/Time	T <sub>SOLD</sub>			260/10	°C/sec	Note (1)
Lead Soldering Temperature/Time	T <sub>SOLD</sub>			380/10	°C/sec	Note (2)

Note (1). Suitable for wave solderin

Note (2). Only for soldering by iron

### Recommended Operating Conditions

Parameter	Symbol	Min.	Typ.	Max.	Unit	Note
Ambient Operating Temperature	T <sub>A</sub>	0		70	°C	Without air flow
Ambient Humidity	HA	5		70	%	Non-condensing
Power Supply Voltage	V <sub>CC</sub>	3.13	3.3	3.47	V	
Power Supply Current	I <sub>CC</sub>			280	mA	
Power Supply Noise Rejection				100	mVp-p	100Hz to 1MHz
Transmission Distance				20	KM	

### Specification of Transmitter

Parameter	Symbol	Min.	Typ.	Max.	Unit	Note
Average Output Power	P <sub>OUT</sub>	-15		-8	dBm	
Extinction Ratio	ER	8.2			dB	
Center Wavelength	λ <sub>c</sub>	1270	1310	1360	nm	FP Laser
Spectrum Width (RMS)	σ			7	nm	
Transmitter OFF Output Power	P <sub>Off</sub>			-32	dBm	
Optical Rise/Fall Time	t <sub>r</sub> /t <sub>f</sub>			3	ns	Note (1)
Total Jitter	t <sub>J</sub>			1	ns	Note (2)
Output Eye Mask	Compliant with ITU G957(class 1 laser safety)					Note (3)

Add: 3rd floor Block 2, Tianlong Science Industry Park, Kengzhi Town, Longgang Area, Shenzhen, China.

Tel: 86-755-86101649

Fax: 86-755-86101640

Dec 10 / 2011

E-mail:sales@modulelink.net

Website: www.modulelink.net

Rev.1.3



**Modulelink(Shenzhen) Technology Co., Ltd.**

Http://www.modulelink.net

Optical network solutions provider

Note (1). These are unfiltered 20-80% values

Note (2). Measure at 2<sup>23</sup>-1 NRZ PRBS pattern

Note (3). Transmitter eye mask definition

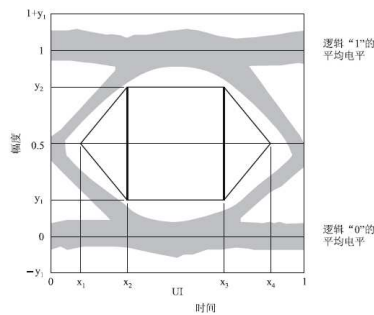

	STM-1	STM-4
$x_1/x_4$	0.15/0.85	0.25/0.75
$x_2/x_3$	0.35/0.65	0.40/0.60
$y_1/y_2$	0.20/0.80	0.20/0.80

**Specification of Receiver**

Parameter	Symbol	Min.	Typ.	Max.	Unit	Note
Input Optical Wavelength	$\lambda_{IN}$	1450	1550	1610	nm	PIN-PD
Receiver Sensitivity	$P_{IN}$			-28	dBm	Note (1)
Input Saturation Power (Overload)	$P_{SAT}$	-8			dBm	
Signal Detect -Assert Power	$P_A$			-29	dBm	
Signal Detect -Deassert Power	$P_D$	-44			dBm	Note (2)
Signal Detect Hysteresis	$P_A-P_D$	0.5	2	6	dB	
Data Output Rise/Fall time	$t_r/t_f$			2.5	ns	Note (3)

Note (1). Measured with Light source 1550nm, ER= 8.2dB; BER = <math>10^{-10}</math> @PRBS=2<sup>23</sup>-1 NRZ

Note (2). When SD deasserted, the RX-LOS output is High-level (fixed)

Add: 3rd floor Block 2, Tianlong Science Industry Park, Kengzhi Town, Longgang Area, Shenzhen, China.

Tel: 86-755-86101649

Fax: 86-755-86101640

Dec 10 / 2011

E-mail:sales@modulelink.net

Website: www.modulelink.net

Rev.1.3



Modulelink(Shenzhen) Technology Co., Ltd.

Http://www.modulelink.net

Optical network solutions provider

Note (3). These are 20%~80% values.

### Electrical Interface Characteristics

Parameter	Symbol	Min.	Typ.	Max.	Unit	Note
<b>Transmitter</b>						
Total Supply Current	I <sub>cc</sub>			A	mA	Note (1)
Transmitter Disable Input-High	V <sub>DISH</sub>	2		V <sub>cc</sub> +0.3	V	
Transmitter Disable Input-Low	V <sub>DISL</sub>	0		0.8	V	
Transmitter Fault Input-High	V <sub>DISL</sub>	2		V <sub>cc</sub> +0.3	V	
Transmitter Fault Input-Low	V <sub>TXFH</sub>	0		0.8	V	
<b>Receiver</b>						
Total Supply Current	I <sub>cc</sub>			B	mA	Note (1)
LOSS Output Voltage-High	V <sub>LOSH</sub>	2		V <sub>cc</sub> +0.3	V	LVTTTL
LOSS Output Voltage-Low	V <sub>LOSL</sub>	0		0.8	V	

Note (1). A (TX)+ B (RX) = 280mA (Not include termination circuit)

### Mechanical Specifications (Unit:mm)

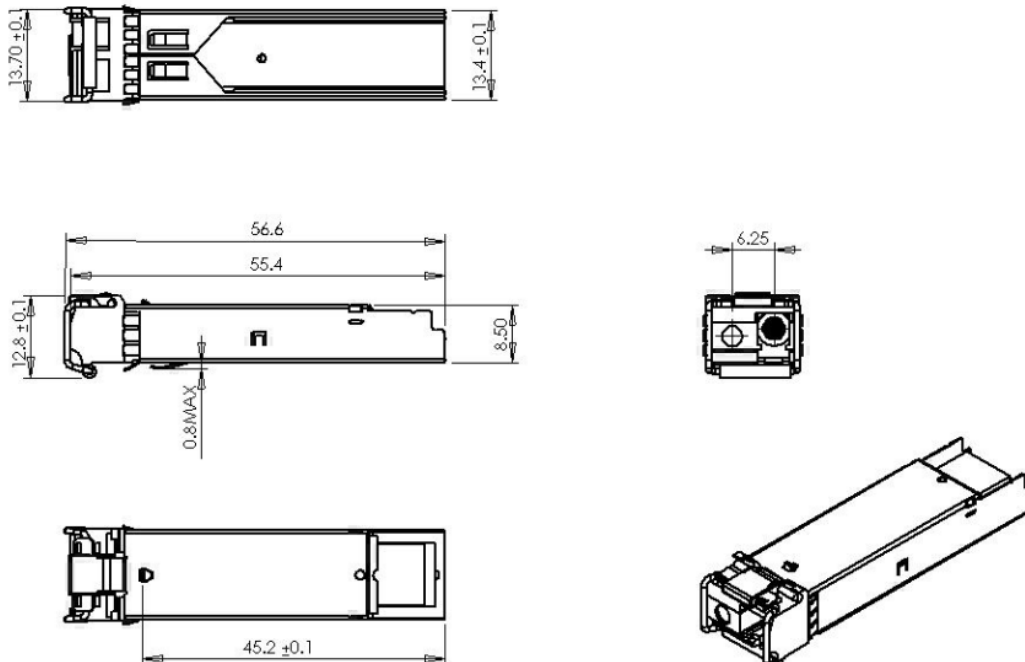

**MSFP-155M-BIDI20**

Add: 3rd floor Block 2, Tianlong Science Industry Park, Kengzhi Town, Longgang Area, Shenzhen, China.

Tel: 86-755-86101649

Fax: 86-755-86101640

Dec 10 / 2011

E-mail:sales@modulelink.net

Website: www.modulelink.net

Rev.1.3