

Schematic:

REV.	ECN NO.	DESCRIPTION	DATE	APPD
A	REL		2010/05/31	

PCB SIDE TO PHY

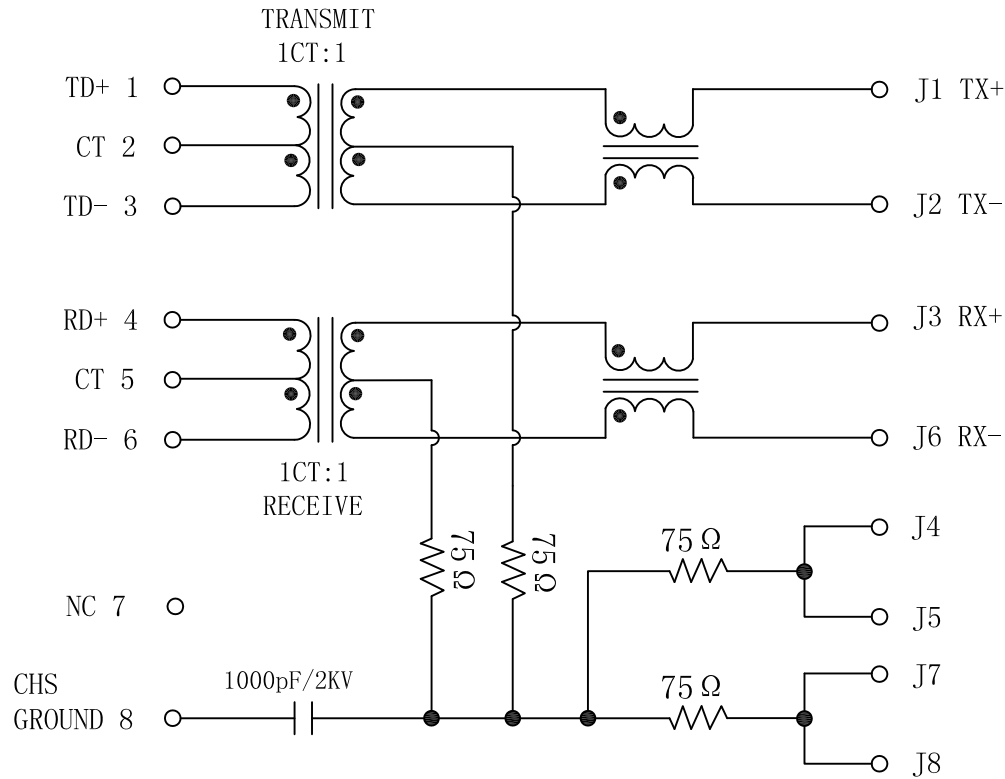

CABLE SIDE

ELECTRICAL SPECIFICATIONS @25°C

- Turn Ratio ( $\pm 2\%$ ):  
TX=1CT:1CT      RX=1CT:1CT
- Inductance OCL: 350uH MIN  
@ 100KHz/0.1V 8mA DC Bias
- Insertion Loss:  
-1.0dB MAX @ 1.0-100MHz
- Return Loss:  
-18dB MIN @ 1-30MHz  
-15dB MIN @ 30-60MHz  
-12dB MIN @ 60-80MHz  
-10dB MIN @ 80-100MHz
- Cross talk:  
-40dB MIN @ 30MHz  
-35dB MIN @ 60MHz  
-30dB MIN @ 100MHz
- Common Mode Rejection:  
-40dB MIN @ 30MHz  
-35dB MIN @ 60MHz  
-30dB MIN @ 100MHz
- Hipot Test: 1500Vrms
- Operating Temperature Range: -40°C TO +85°C

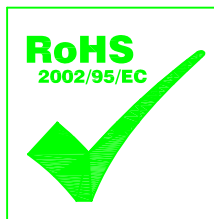

X:X	$\pm 0.25$	APPD:	LINK-PP INT'L TECHNOLOGY CO., LIMITED	
X:XX	$\pm 0.20$	CHKD:	TITLE: RJ45 Connector with 10/100 Base-T Integrated Magnetics	
X:XXX	$\pm 0.05$	DR: TOM		
ANGLES	$\pm 1^\circ$	UNIT: mm	PART NO.: LPJ0012DNL	
	SCALE: 2/1	SHEET: 1/2	REV: A	DWG NO.: LP10053135

# Mechanical:

REV.	ECN NO.	DESCRIPTION	DATE	APPD
A	REL		2010/05/31	

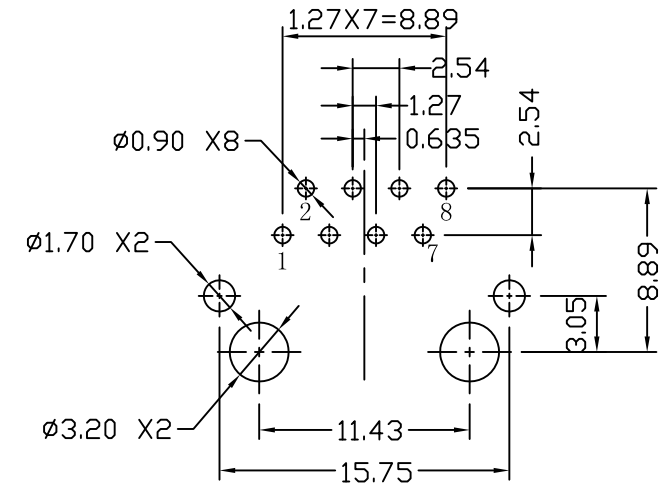
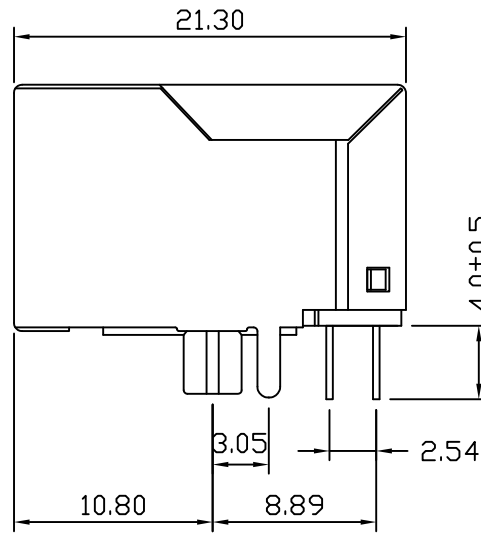
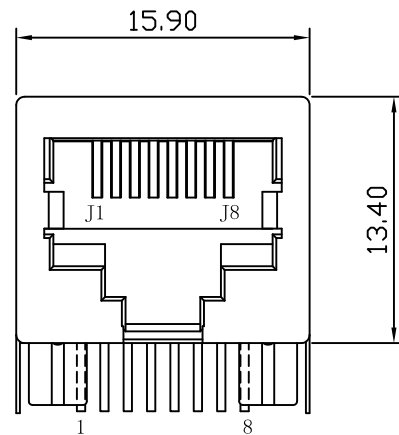

SUGGESTED PCB LAYOUT(TOP VIEW)

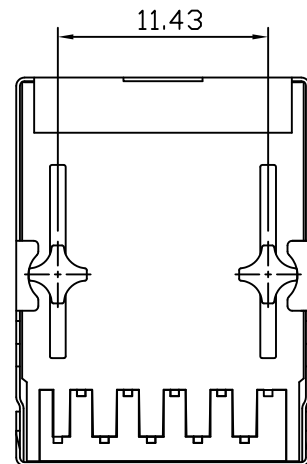

## NOTES:

1. Designed to support application, such as SOHO (ADSL modems), LAN-on-Motherboard (LOM), hub and Switches.
2. Meets IEEE 802.3 specification
3. Connector Materials:  
 Housing: Thermoplastic UL94V-0  
 Contact/Shield: Copper alloy  
 Shield plating: Nickel  
 Contact plating: Gold 6 micro-inches min. In contact area.
4. Wave solder tip temperature: 265°C Max  
 Wave solder tip temperature time: 5 Sec Max.

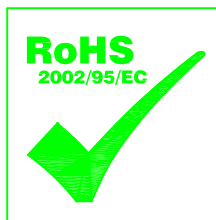

X:X	±0.25	APPD:	LINK-PP INT'L TECHNOLOGY CO., LIMITED	
X:XX	±0.20	CHKD:	TITLE: RJ45 Connector with 10/100 Base-T Integrated Magnetics	
X:XXX	±0.05	DR: TOM	PART NO.: LPJ0012DNL	
ANGLES	±1°	UNIT: mm	DWG NO.: LP10053135	
	SCALE: 2/1	SHEET: 2/2	REV: A	