

# Non-explosively actuated release mechanisms and cell bypass switches



## Over 45 years of mission-critical flight heritage

Eaton's release mechanisms and cell bypass switches, including G&H Technology™ solutions, utilize non-explosive initiators to provide rapid responses with low power consumption across a wide range of temperatures.

- Over 45 years of flight heritage
- Fragment and debris-free operation
- Electrical compatibility with pyro-activation circuits
- No precautions for explosive materials required

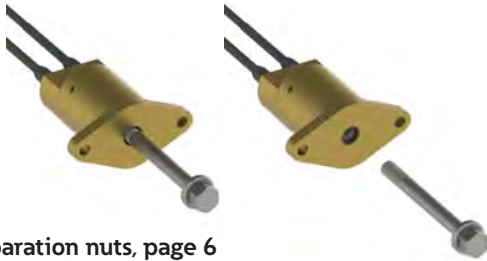

### Separation nuts, page 6

Standard load ratings from 4500 to 9500 lbs. (20 to 42.2 kN). Options include cryogenic ratings, nickel platings, and custom load ratings, flanges and cables.



### Pin-pullers, page 9

Standalone devices and integrated solutions include compression releases, structural separation systems, and pin-puller-initiated umbilical connectors and in-flight disconnects.



### Tension-releases, page 12

Solutions include 250 to 1300 pound (1.1 to 5.8 kN) standard load ratings and miniaturized releases that occupy less than 1/3 inch<sup>3</sup> (5cm<sup>3</sup>).

Non-explosive actuators eliminate the need for the safeguards required to provide protection from the explosive materials used in pyrotechnic devices and remove the potential safety issues resulting from debris release during pyrotechnic testing and operation.

Eaton also provides actuators with field and factory refurbishment capabilities and field-resettable mechanical test initiators that provide significant cost savings when compared to the replacement costs of one-shot pyrotechnic devices.



### Cable release mechanisms, page 14

Single and dual-cable releases with standard load ratings from 80 to 267 lbs. (355 to 1187 N) per cable and load orientations parallel or perpendicular to the mounting flange.

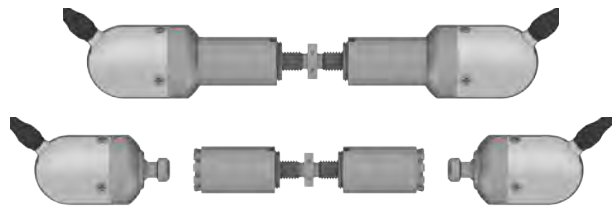

### Tension links, page 16

Tension links function as clamp fasteners until redundant initiators release their actuator shafts to facilitate separation in V-band (Marman) clamp applications.



### Cell bypass switches, page 18

Bypass switches reroute power in response to failed battery and solar-panel cells with lower voltage drops than diode-bypass systems and higher reliability than relays.

Heritage-proven technologies support rapid releases, field resettable testing and safe handling and deployment



**Split-spool initiator theory of operation, page 4**

Eaton's non-explosive, split-spool technologies have extensive flight heritage in release mechanism and electrical-bypass-switch applications.



**Actuator refurbishment capabilities, page 5**

Actuator refurbishment costs are typically less than 20% of the cost of replacing one-shot pyrotechnic devices. Field refurbishment can be performed in less than ten minutes.



**Field resettable, mechanical-test actuators, page 5**

Multiple-test sequences can be facilitated by replacing split-spool initiators with mechanical test initiators that are field resettable in under ten minutes.

## Split-spool technology advantages include rapid releases with low power consumption across a wide range of operating temperatures

	<b>Eaton's Split-Spool Technologies</b>	<b>Explosive Pyrotechnic</b>	<b>Parafin Wax</b>	<b>Shape Memory Alloy</b>	<b>Other Split-Spool Technologies</b>
No precautions for explosive materials required	Yes	No	Yes	Yes	Yes
Fragment and debris free operation	Yes	No	Yes	Yes	Yes
Rapid responses across wide temperature ranges	Yes	Yes	No	No	Yes
Low power consumption	Yes	Yes	No	No	Yes
Field-resettable testing without parts replacement	Yes	No	Yes	Yes	No
Field refurbishment capabilities	Yes	No	Yes	Yes	No
Low imparted shock	Yes	No	Yes	Yes	Yes

# Split-spool initiator theory of operation

Non-explosive, split-spool technologies have extensive flight heritage in release mechanism and electrical-bypass-switch applications. The two images below depict an electrically initiated split-spool assembly before and after load release. Electrically initiated, compression-release devices employ a similar operating sequence that uses the force of an external load to drive the split-spool plunger instead of the force of an internal compression spring.

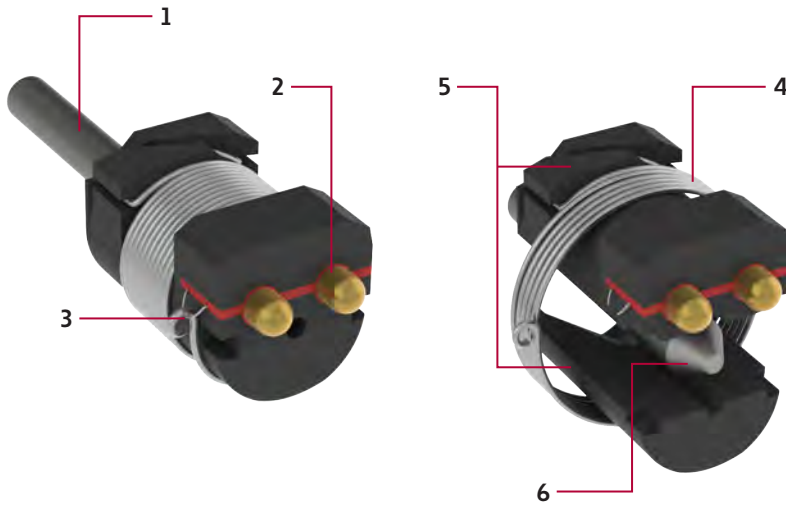

## Operating sequence

1. The initiator is armed by applying compression-spring force to the plunger. The wrapped spool restrains the plunger until actuation.
2. Current is applied to the electrical contacts; power requirements are compatible with pyrotechnic actuator circuitry.
3. Electrical current causes the link wire to open and release the tensile wire wrap.
4. Radial expansion of the tensile-wire wrap releases tension on the split-spool bobbin.
5. Separation of the two halves of the spool is facilitated by the forward movement of the spring-loaded plunger.
6. The forward movement of the plunger initiates pin retraction in pin pullers or release-mechanism activation in other devices.

This separation nut utilizes mechanical initiation instead of electrical initiation. This customer-requested modification was implemented to support application specific, host-system integration requirements.

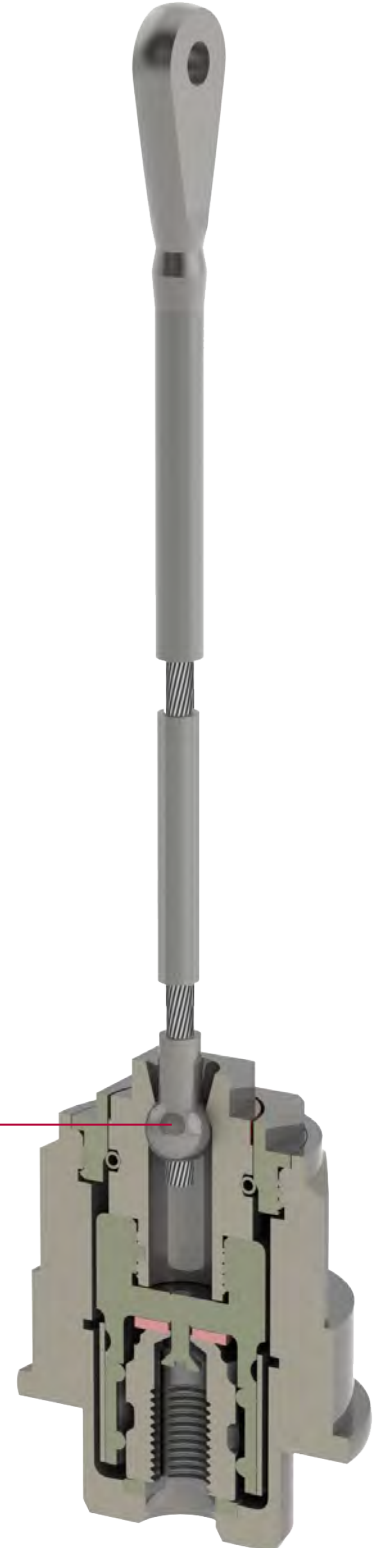

# Refurbishing can reduce actuator-related test costs up to 80%

Many of Eaton's products can be factory or field refurbished in under ten minutes by replacing the expended initiator. Refurbishment costs are typically less than 20% of the expense of replacing one-shot pyrotechnic devices. This can provide significant savings during multiple-actuation sequences required for system testing and qualification.

Split-spool initiators facilitate additional cost savings by eliminating the safety-assurance requirements inherent to test firing pyrotechnic actuators.

In addition to be a standard feature on many Eaton non-explosive actuators, refurbishment capabilities can be implemented in custom solutions.

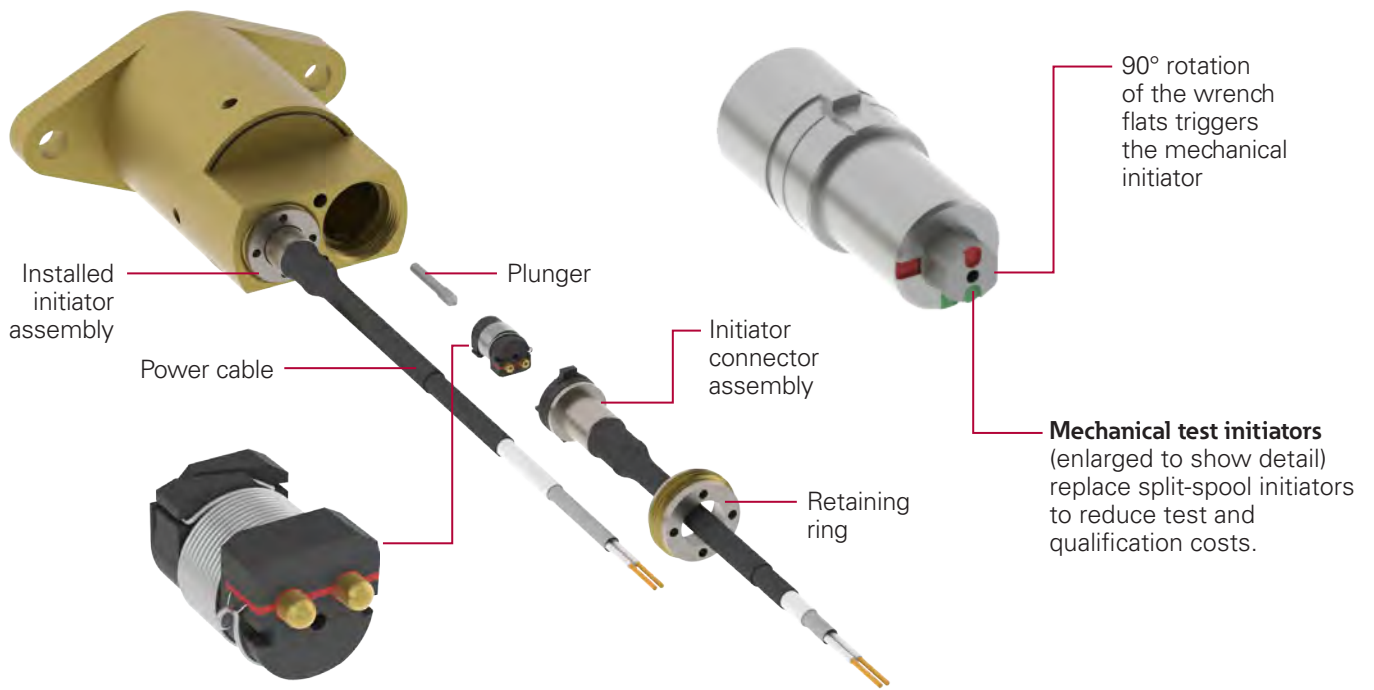

**Replacement split-spool initiators** (enlarged to show detail) are shipped from the factory ready for drop-in installation.

## Mechanical test initiators can be reset in under ten minutes

Multiple-test sequences can also be facilitated by replacing the split-spool initiator and cable assembly with a field resettable, mechanical initiator.

These accessory kits are options for many standard products. Mechanical initiator compatibility can also be implemented as a design feature in custom solutions.

An intuitive, visual confirmation that the mechanical test initiator is armed or actuated is provided by a color-coded status indicator; green – armed and red – actuated.

Installation and testing is extremely straight forward:

- The split-spool initiator, retaining ring, and cable assembly are removed and replaced with the mechanical initiator and retaining plug.
- Test sequences are triggered by a quarter turn of a standard 3/16-inch wrench.
- The mechanical initiator is reset, no parts replacements are required.
- After testing, the mechanical initiator is removed and the actuator parts are re-installed.



## Separation nuts

Eaton's separation nuts are available in redundantly initiated configurations with standard load ratings from 4500 to 9500 lbs. (20 to 42.2 kN).

Custom load ratings and attachments, cables, EMI/RFI and environmental compliances and < 10ms response times are also available.

Additional features and options include:

- Rapid releases with low power consumption.
- Fragment and debris-free operation.
- No precautions for explosive materials required.
- Electrical compatibility with pyro-activation circuits.
- Field refurbishable by spool replacement.
- Optional mechanical initiators are field resettable and support multiple test releases.
- Plating options include cryogenic rated and nickel.



Heritage includes space station resupply missions, Mars landers and multiple satellite programs.

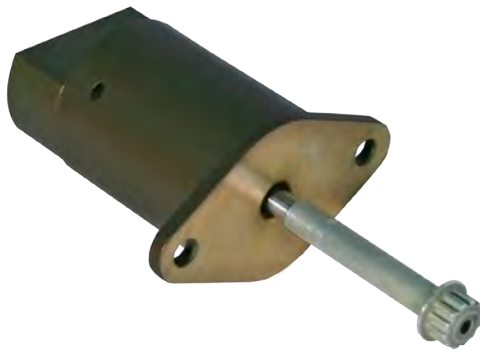

Separation nuts utilize split-spool initiators as hold down preloading assemblies and 1/4 or 5/16 inch load attachment bolts as hold down release actuators. After electrical initiation, load deployment is facilitated by threaded-segment release of the load-attachment bolt.

### Theory of operation

The cutaway drawing to the right depicts a separation nut configured with redundant split-spool initiators. Electrical activation of either initiator assembly will release the bolt.

- When armed, the spool assemblies constrain the plungers and rocker preventing the threaded segments from releasing the bolt.
- Initiation of either spool assembly unlocks the plunger and rocker allowing the expanding compression spring to power the release of the bolt.

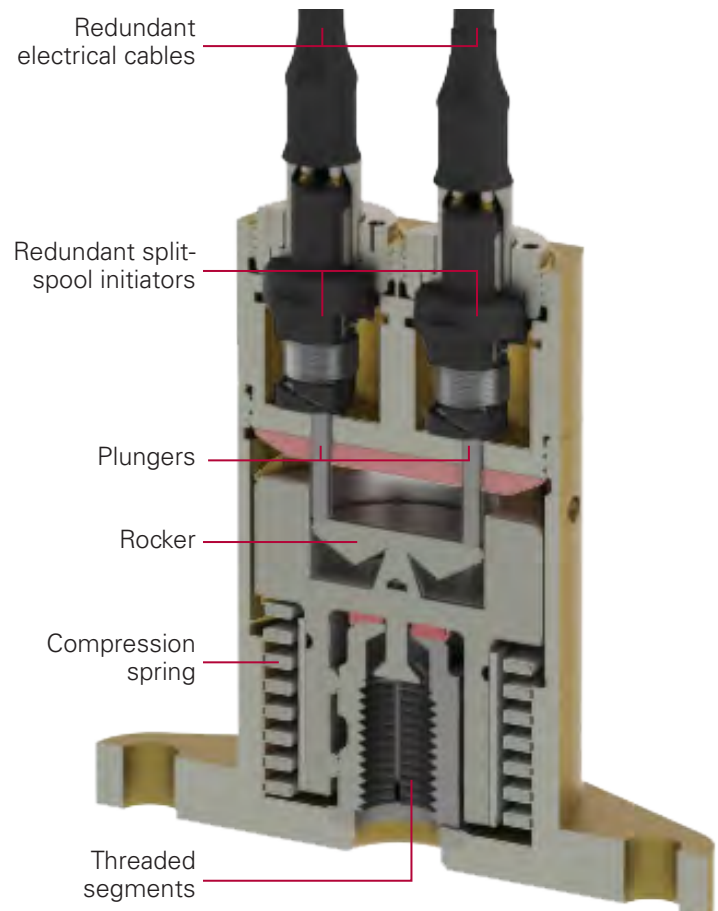

## Separation nut technical specifications

<b>Performance</b>	<b>1/4" Bolt</b>	<b>5/16" Bolt</b>
Design load	4500 pounds (20 kilonewtons)	9500 pounds (42.2 kilonewtons)
Operating temperature	-238°F to 266°F (-150°C to 130°C), cryogenic option is qualified to -351°F (-213°C)	
Initiator type	Split spool	
Response time	<25ms @ 4.5A per initiator*	
Redundancy	Dual power cables, initiators, and plungers	
Release system	Three threaded segments	

\*< 10ms response times can be attained by optimizing the actuation current. Please contact Eaton for more information.

<b>Mechanical Specifications</b>	<b>1/4" Bolt</b>	<b>5/16" Bolt</b>
Approximate weight	0.5 pounds (226g)	
Bolt insertion depth	0.600 - 0.625" (15.24 – 15.87mm)	
Imparted shock	~1000g's max @ 4500 lbs. preload	~2000g's max @ 7800 lbs. preload
Body materials	7075 Aluminum or stainless steel	
Body finishes	Nickel plating and gold or black anodizing	
Segment materials	17-4, 15-5 stainless steel	17-4, 15-5, MP35, custom 455
Bolt type	1/4 - 28	5/16 - 24
Mounting	Flange, flangeless, or threaded mounting	

<b>Electrical Characteristics</b>	<b>1/4" Bolt</b>	<b>5/16" Bolt</b>
Actuation current	4.5A for 25ms per initiator recommended	
Insulation resistance	5 megaohms at 500VDC	
No-fire current	0.6A for five minutes	
Link resistance	1.0 ohms nominal, each link	
Grounding isolation	< 2.5 milliohms per joint	

## Separation nut technical specifications (continued)

<b>Environmental</b>	<b>1/4" Bolt</b>	<b>5/16" Bolt</b>
Mechanical shock (induced)	10,000g's	10,000g's
Random vibration	40 grms	40 grms
Maximum humidity	< 90% RH	< 90% RH
Operating temperature	-238°F to 266°F (-150°C to 130°C), cryogenic option is qualified to -351°F (-213°C)	
Storage life	20 years	20 years

<b>Environmental</b>	<b>1/4" Bolt</b>	<b>5/16" Bolt</b>
Development date	1993	2001

## Mounting and connector configurations

Eaton's separation nuts are available with a wide range of mounting and electrical-connector options. All configurations deliver high-load ratings and redundant initiations from compact form factors.

The mechanical drawings presented below provide reference dimensions for a few representative heritage configurations. Actual dimensions are based on customer requirements.

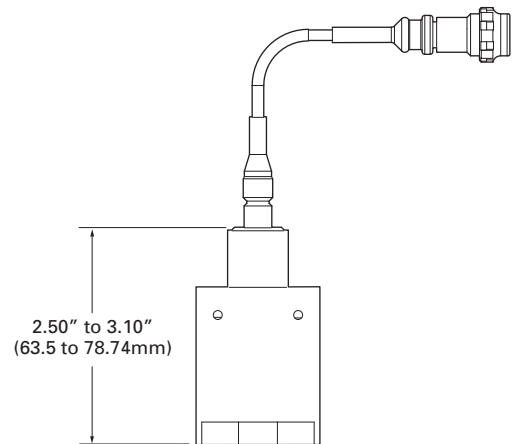
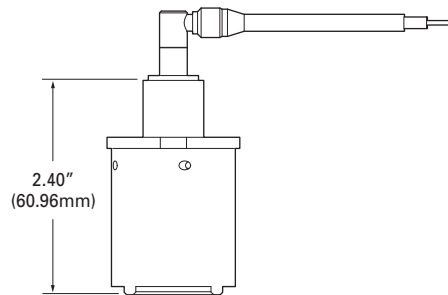
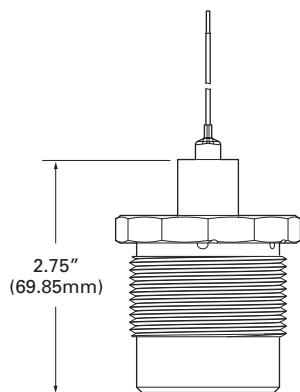
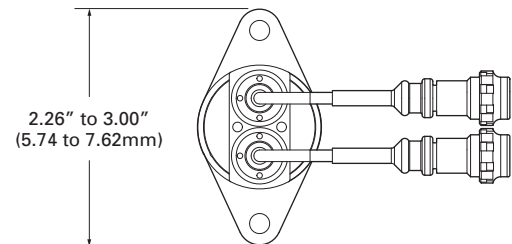
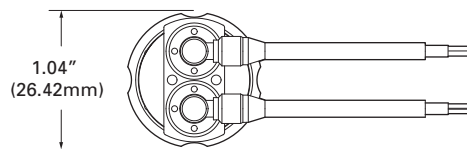
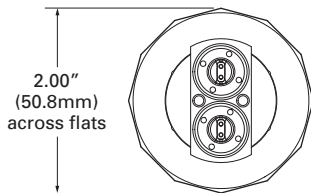



## Pin pullers and compression release devices

Eaton can provide pin pullers and compression release devices in a wide range of configurations – from standalone devices to integrated solutions.

Pin-puller initiated, integrated solutions include stage separation, payload release, flight termination, umbilical connectors and in-flight disconnects.

Additional features include:

- Rapid releases with low power consumption.
- Fragment and debris-free operation.
- Electrical compatibility with pyro-activation circuits.
- No precautions for explosive materials required.
- Field refurbishment significantly reduces actuator-related test and qualification costs when compared to one-shot pyrotechnic devices.

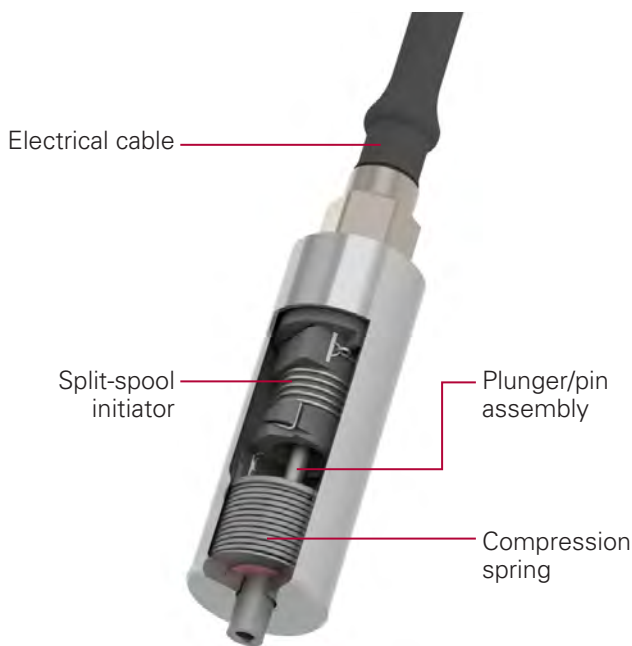

### Theory of operation

The cutaway drawing depicts a field refurbishable pin puller.

- When armed, the split-spool initiator constrains the plunger/pin assembly and prevents retraction.
- Electrical activation of the spool assembly unlocks the plunger/pin assembly allowing pin retraction as the compression spring expands.
- Compression releases operate in a similar manner to pin pullers except that pin retraction is driven by the external load instead of an internal compression spring.



Eaton pin puller and compression release heritage includes interconnect releases during launch and stage separation and antenna, solar panel, instrument, and sub-satellite releases on satellites and spacecraft.

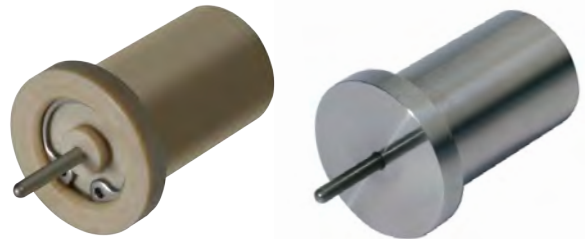

The left-hand compression release was designed to release smart-bomb guidance fins. This extremely compact solution features a 200 lb. (889 N) load rating.



Application-specific solutions are available in a wide range of mounting configurations.

## Pin puller actuated, structural-separation systems

Eaton's custom capabilities include structural-separation mechanisms that utilize pin pullers for actuation. Applications include stage and payload release and flight termination systems.

Eaton developed the solution depicted below for a flight termination application including the housing, redundant pin pullers, and all of the mechanical components required for restraint and separation.

This heritage-proven design can be used in harsh environment applications that would otherwise use tension links with Marmam clamps less than 15 inches (38cm) in diameter.



Program heritage includes structural separation to facilitate flight termination of inert ordnance.

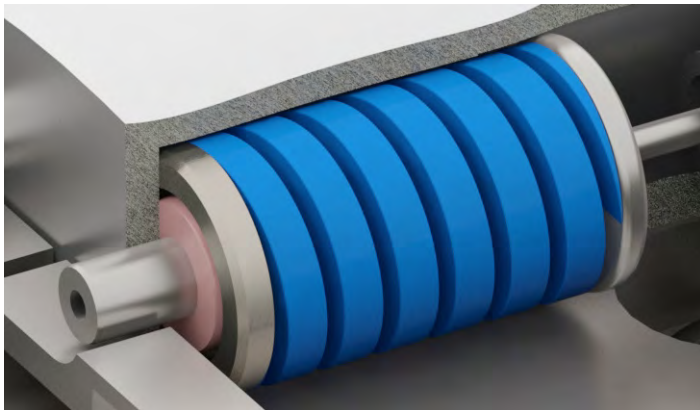

The restraining band has been cut away to show details of a pin puller utilized in the flight termination system depicted below.

This solution joins the two structural sections until electrical actuation initiates separation:

- The two structural sections are held together through wedge segments captured in the cavities of the forward section and a slot in the aft section.
- The wedge segments are held in place with a preload band restrained on both ends by pin pullers.
- Actuation of either pin puller releases the band allowing the wedge segments to move radially outward.
- The expansion of the ejection wave washer initiates release of the forward section from the aft section.

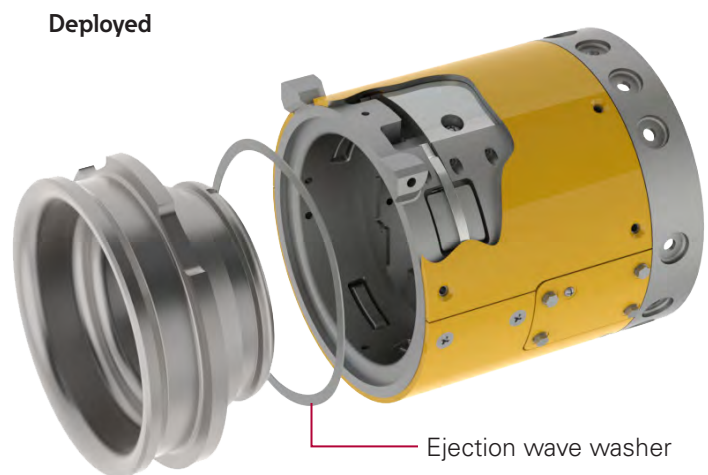
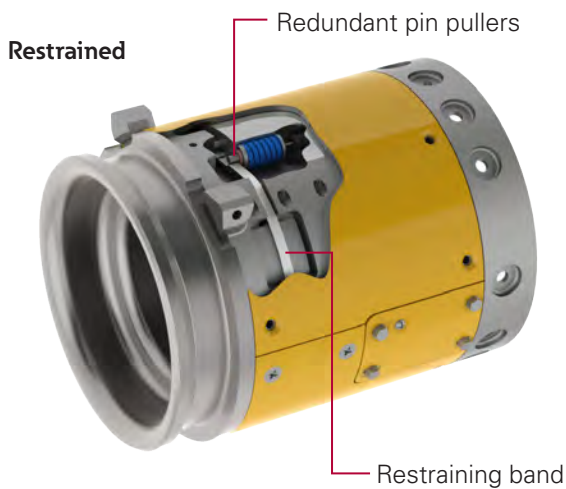

## Pin puller actuated umbilicals and in-flight disconnects

Eaton can leverage a broad range of heritage-proven technologies to quickly develop pin-puller-actuated umbilical connectors and in-flight disconnects.

The umbilical solutions depicted below were qualified for upper-stage deployment on multiple applications including manned-spaceflight programs.

- A pin puller initiates separation and is integrated with the cable assembly depicted below.
- The lanyard-release plug provides mechanical redundancy.



Program heritage for the in-flight disconnect depicted below includes ICBM applications. This rendering has the cover removed to show the redundant pin pullers that release the restraining band. After release, the restraining band moves radially outward to facilitate connector separation.

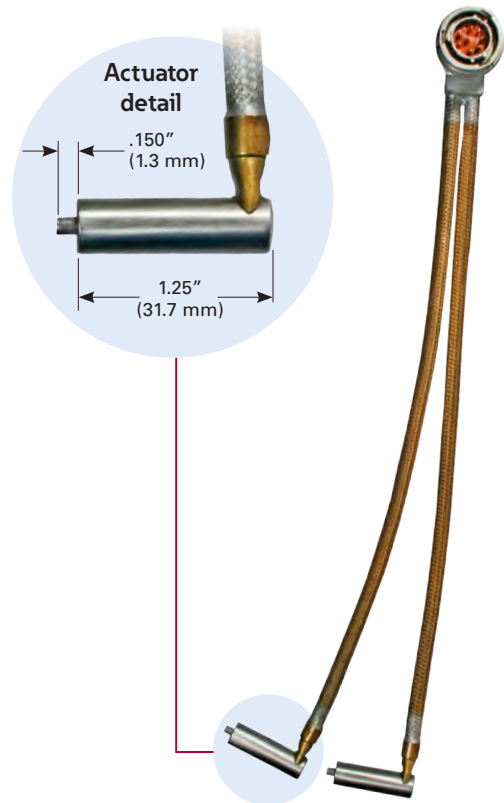
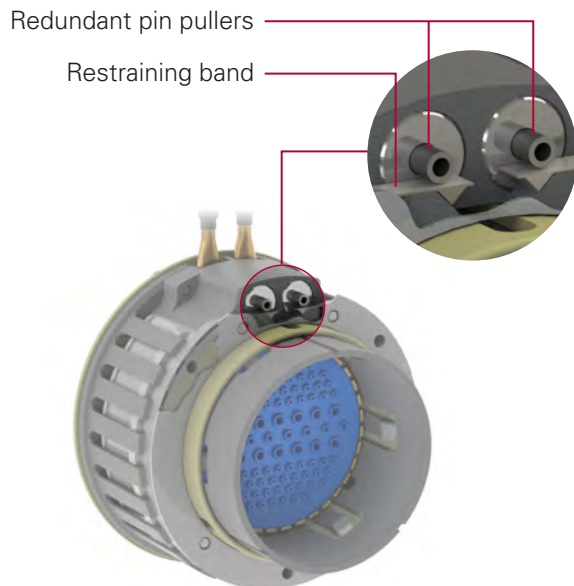

The redundant pin-puller solution depicted above includes an integrated cable assembly that is designed to work in high EMI/RFI environments and is qualified for connector separations on ICBM re-entry vehicles.



Eaton's interconnect-separation technologies also include lanyard releases and mechanically-initiated separation nuts as utilized in this MIL-DTL-38999-array umbilical connector.



## Tension releases

Eaton's tension releases are available in standard load ratings from 250 to 1300 lbs. (1.1 to 5.8 kN) and include miniaturized solutions that occupy less than 1/3 inch<sup>3</sup> (5cm<sup>3</sup>).

Custom load ratings and attachments, cables, EMI/RFI and environmental compliances and < 10ms response times are also available.

Additional features and options include:

- Fragment and debris-free operation.
- Rapid releases with low power consumption.
- No precautions for explosive materials required.
- Factory refurbishment significantly reduces actuator-related test and qualification costs.



Program qualifications include emergency detachment of night-vision systems in combat aircraft, warhead releases in exoatmospheric military vehicles and solar panel and antenna array releases on multiple satellite programs.

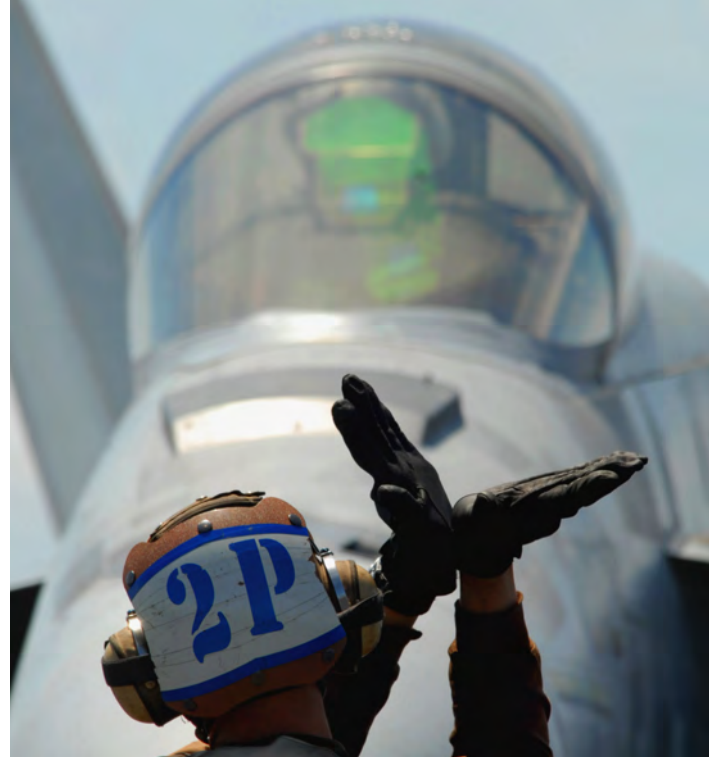

Parameter	1183 Releases	8038 Releases	8024 Releases
Tensile load rating	250 lbs. (1.1 kN)	625 lbs. (2.8kN)	1300 lbs. (5.8 kN)
Minimum load	15 lbs. (67 N) recommended, contact Eaton to discuss your application		
Separation time	<25ms @ 4.5A*	<25ms @ 4.5A*	<25ms @ 4.5A*
Recommended actuation current	4.5A for 25ms	4.5A for 25ms	4.5A for 25ms
Nominal link resistance	1.0 ohms	1.0 ohms	1.0 ohms
No-fire test current	0.6A for 5 minutes	0.6A for 5 minutes	0.6A for 5 minutes
Initiator type	Split-spool initiator; options include redundant initiation		
Load attachments	Clevis pins, shafts, threads and application-specific load attachments		
Materials	1183 & 8024 - Corrosion-resistant steel, except molded-epoxy insulator 8038 - Anodized or nickel plated aluminum, stainless steel		
Weight	12.5 gm (0.44 oz)	28.3 gm (2.2 oz)	28.3 gm (2.2 oz)
Operating temperature range	-29°F to 131°F (-34°C to 55°C)	-200°F to 300°F (-128°C to 149°C)	-200°F to 300°F (-128°C to 149°C)

\*< 10ms response times can be attained by optimizing the actuation current. Please contact Eaton for more information.

# Tension release mechanical drawings

1183 releases

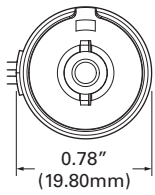
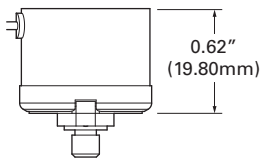

8038 releases

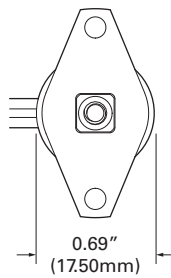
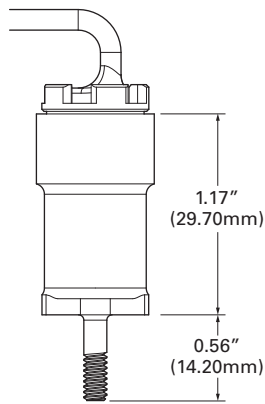

8024 releases

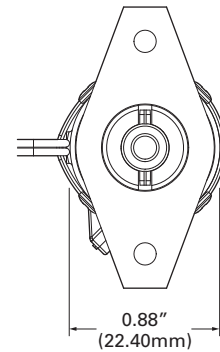
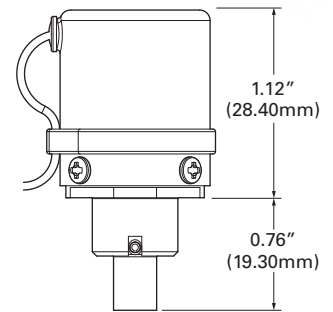

## Cable release mechanisms

Eaton's cable release mechanisms are available in single and multiple cable configurations with standard load ratings from 80 to 267 lbs. (355 to 1187 N) per cable.

Application specific load ratings and attachments, cables, EMI/RFI and environmental compliances and < 10ms response times are available.

Additional features and options include:

- Rapid releases with low power consumption.
- No precautions for explosive materials required.
- Electrical compatibility with pyro-activation circuits.
- Field refurbishable by spool replacement.
- Optional mechanical initiators are field resettable.
- Load orientations parallel or perpendicular to the mounting flange.



Flight heritage includes the deployment of solar panels and antenna arrays on multiple satellite programs.



A field resettable, mechanical initiator has been installed on this cable release to enable multiple test releases without the need for actuator refurbishment.

### Electrical Specifications

Actuation current	4.5A for 25ms per initiator recommended
Link resistance	1.0 ohms nominal, each link
Insulation resistance	1.0 megaohms minimum at 500VDC
Dielectric strength	5 milliamps maximum leakage current at 750VAC
No-fire test current	0.6 amps for five minutes
Electrical connections	20AWG shielded pigtails

# Cable release mechanical and environmental specifications

## Mechanical & Environmental Specifications

Initiator type	Split-spool initiator, field refurbishable
Redundancy	Electrically and mechanically redundant
Separation time	<25ms @ 4.5A per initiator*
Tensile load rating	80 to 267 pounds (355 to 1187 newtons) per cable standard ratings Application-specific load ranges are also available
Load connections	Flexible cables or rigid rods with .190-24UNF-2A or .190-24UNC-2A threads
Load-axis orientation	Configurations available with the load axis parallel or perpendicular to the mounting flange
Weight	10.5 ounces (300 grams) typical maximum
Operating temperature	-6°F to 217°F (-21°C to 102°C)

\*< 10ms response times can be attained by optimizing the actuation current. Please contact Eaton for more information.

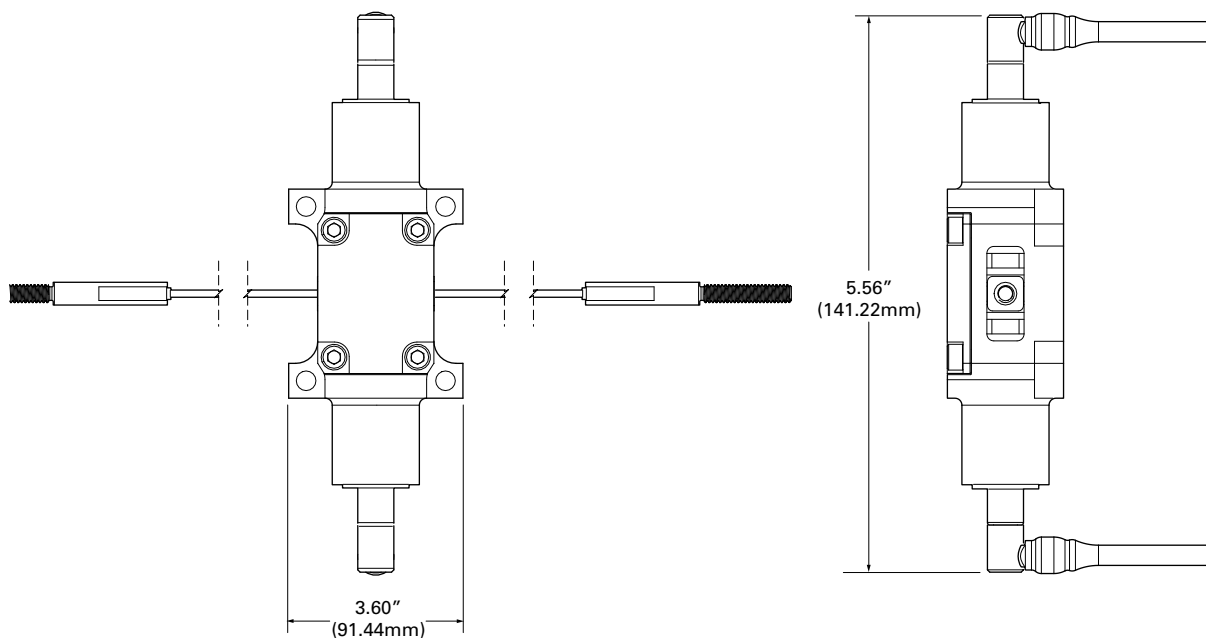



# Tension links

Eaton's 8014 tension links are available with standard load ratings up to 2000 pounds (8.9 kilonewtons) and function as clamp fasteners until redundant spilt-spool initiators release their actuator shafts to facilitate separation.

These heritage-proven devices are primarily designed for harsh environment circular-clamp applications, such as Marman and V-band clamps.

Custom load ratings and attachments, cables, application-specific EMI/RFI and environmental compliances, < 10ms response times and complete clamping mechanisms are also available.

Additional features include:

- Electrically and mechanically redundant.
- No precautions for explosive materials required.
- Rapid releases with low power consumption.
- Factory refurbishment significantly reduces actuator-related test and qualification costs.
- Electrical compatibility with pyro-activation circuits.



Tension link qualifications include missile systems and Mars landers.

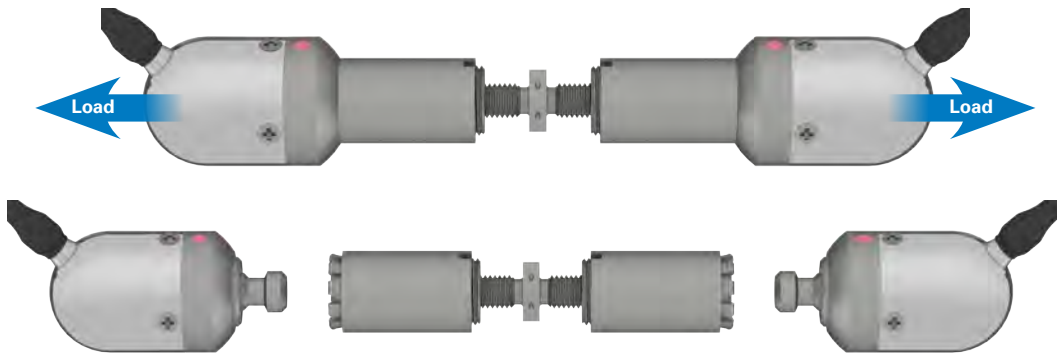

8014 tension links are electrically and mechanically redundant. Initiation of the left or right actuator mechanism, or both, will initiate clamp release.

## Electrical Specifications

Actuation current	4.5A for 25ms per initiator recommended
Link resistance	1.0 ohms nominal, each link
No-fire test current	0.6 amps for five minutes

# Tension link mechanical and environmental specifications

## Mechanical & Environmental Specifications

Initiator type	Split-spool initiator, factory refurbishable
Separation time	<25ms @ 4.5A per initiator*
Separation stroke	0.12 inch (3mm) each side
Tensile load	2000 pounds (8.9 kilonewtons)
Minimum required load	15 pounds (66 newtons)
Redundancy	Electrically and mechanically redundant
Materials	Corrosion-resistant steel, all parts except insulators
Weight	7.5 ounces (213 grams) maximum
Operating temperature	-80°F to 220°F (-62°C to 104°C)

\*< 10ms response times can be attained by optimizing the actuation current. Please contact Eaton for more information.

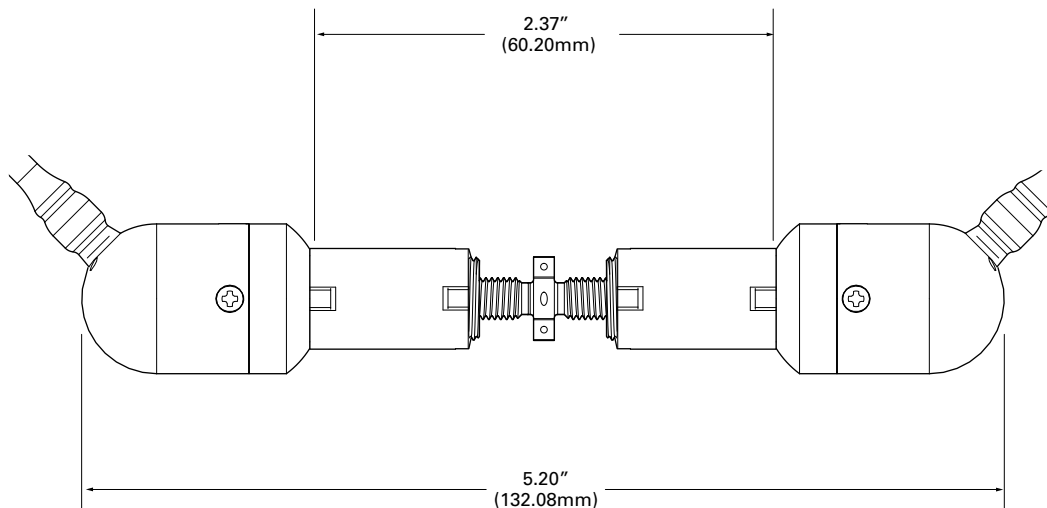

# Cell bypass switches

Eaton's cell bypass switches can be used to permanently open or close single or multiple electrical circuits. Applications include terminating an event, sequencing events, bypassing failed battery or solar panel cells and disconnecting or rerouting power in response to fault conditions.

When compared to relays, split-spool-initiated bypass switches enable faster response times, reduced weight, and increased reliability especially in high shock and vibration environments.

Additional advantages include:

- Significantly lower voltage drops than diode-bypass systems; < 20mV @ 100A and 40mV @ 200A.
- Rapid releases with low power consumption.
- No precautions for explosive materials required.
- Fragment and debris-free operation.
- Field refurbishable by spool replacement.
- Electrical compatibility with pyro-activation circuits.

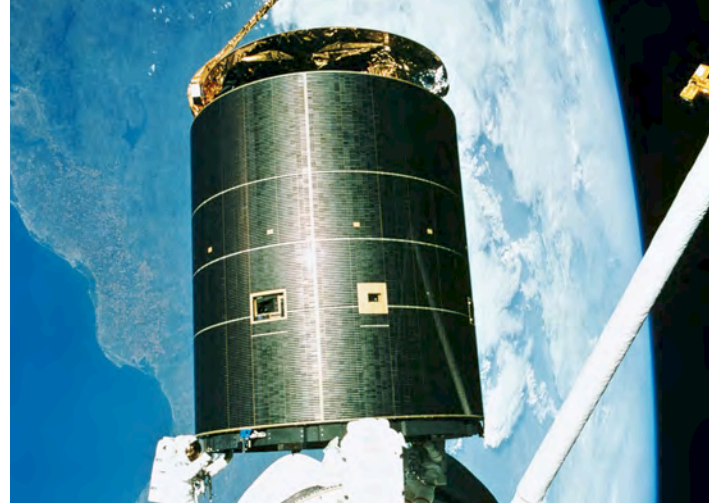

Flight heritage includes power management on multiple satellite programs.

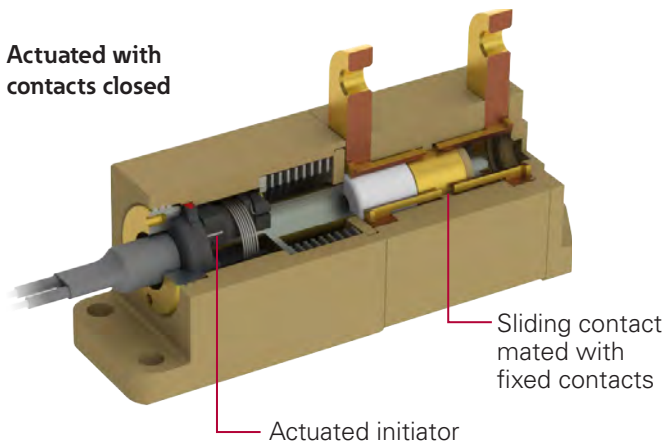
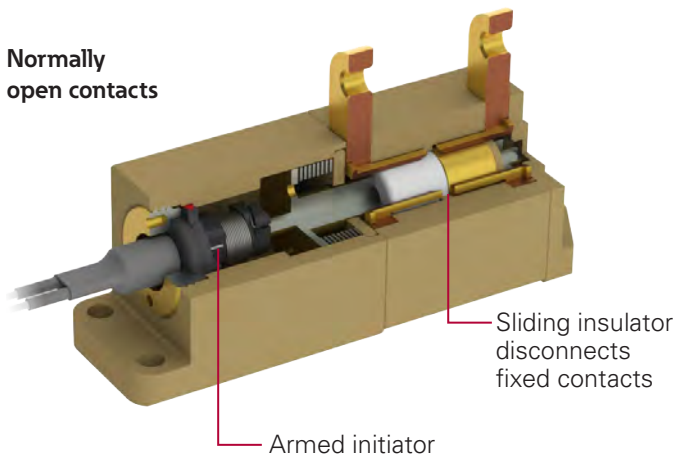

## Theory of operation

The actuation sequence of the depicted single pole, single throw switch is representative of the operation of all of Eaton's split-spool-initiated bypass switches.

- When armed, the initiator locks the sliding insulator/contact assembly with the insulator positioned between the fixed contacts.
- Initiator actuation unlocks the insulator/contact assembly allowing the sliding contact to mate with the fixed contacts as the compression spring expands.



Double (depicted above) and single-throw design platforms (depicted to the left) can be quickly optimized to support application-specific requirements.

# Custom bypass-switch development

Eaton’s heritage-proven technologies and design platforms accelerate custom solution development for a broad range of electrical-switch requirements:

- Single-and-multiple pole and throw combinations.
- Normally open or closed contacts.
- Make before break or break before make switching.
- Simultaneous or sequenced multi-pole operation.
- Application-specific form factors and materials.

- Customer defined electrical performance including high current ratings - continuous and surge.
- Extreme shock, vibration, corrosive environments, and operating temperatures including cryogenic.

Specifications for 1181 bypass switches are presented as capabilities references. Please contact Eaton to discuss quick turn, custom solutions to support your application specific bypass-switch requirements.

### Model 1181 Electrical Specifications

Actuation current	4.5A for 25ms recommended
No-fire test current	0.6 amps for five minutes
Continuous / surge current	200 amps / 350 amps for 120 seconds
Post activation voltage drop	< 20mV @ 100A, 40mV @ 200A
Insulation resistance	5 megaohms minimum @ 600VDC
Dielectric withstand voltage	600Vrms, 60Hz at sea level
Link resistance	1.0 ohms nominal
Electrical protection	Optional blocking diode prevents current flow in the event of cell reversal

### Model 1181 Mechanical & Environmental Specifications

Initiator type	Split-pool initiator
Separation time	25ms @ 4.5A*
Operating temperature range	-15°C to 40°C (5°F to 104°F)
Random vibration	10.7grms
Shock	1960g’s from 2.5 to 10KHz
Weight	3 ounces (85 grams) maximum

\*< 10ms response times can be attained by optimizing the actuation current. Please contact Eaton for more information.

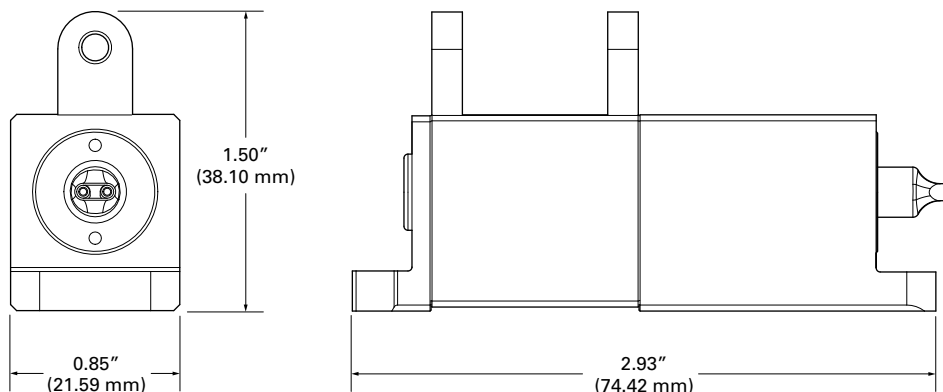

For additional information

- Visit [www.eaton.com/interconnect](http://www.eaton.com/interconnect)
- Call 805.484.0543
- Email [cicustomer.service@eaton.com](mailto:cicustomer.service@eaton.com)

**Eaton**

1000 Eaton Boulevard  
Cleveland, OH 44122  
United States  
[Eaton.com](http://Eaton.com)

Customer Service  
750 West Ventura Blvd.  
Camarillo, CA 93010  
Phone: 805.484.0543 or  
800.840.0502  
[www.eaton.com/interconnect](http://www.eaton.com/interconnect)

© 2014 Eaton  
All Rights Reserved  
Printed in USA  
Publication No. BR800005EN  
June 2015

Eaton is a registered trademark.

All other trademarks are property  
of their respective owners.



*Powering Business Worldwide*