

LOC		DIST		REVISIONS			
P	LTR	DESCRIPTION	DATE	DNW	APVD		
T		REVISED PER 063B-1094-04	26JAN85	KW	SR		

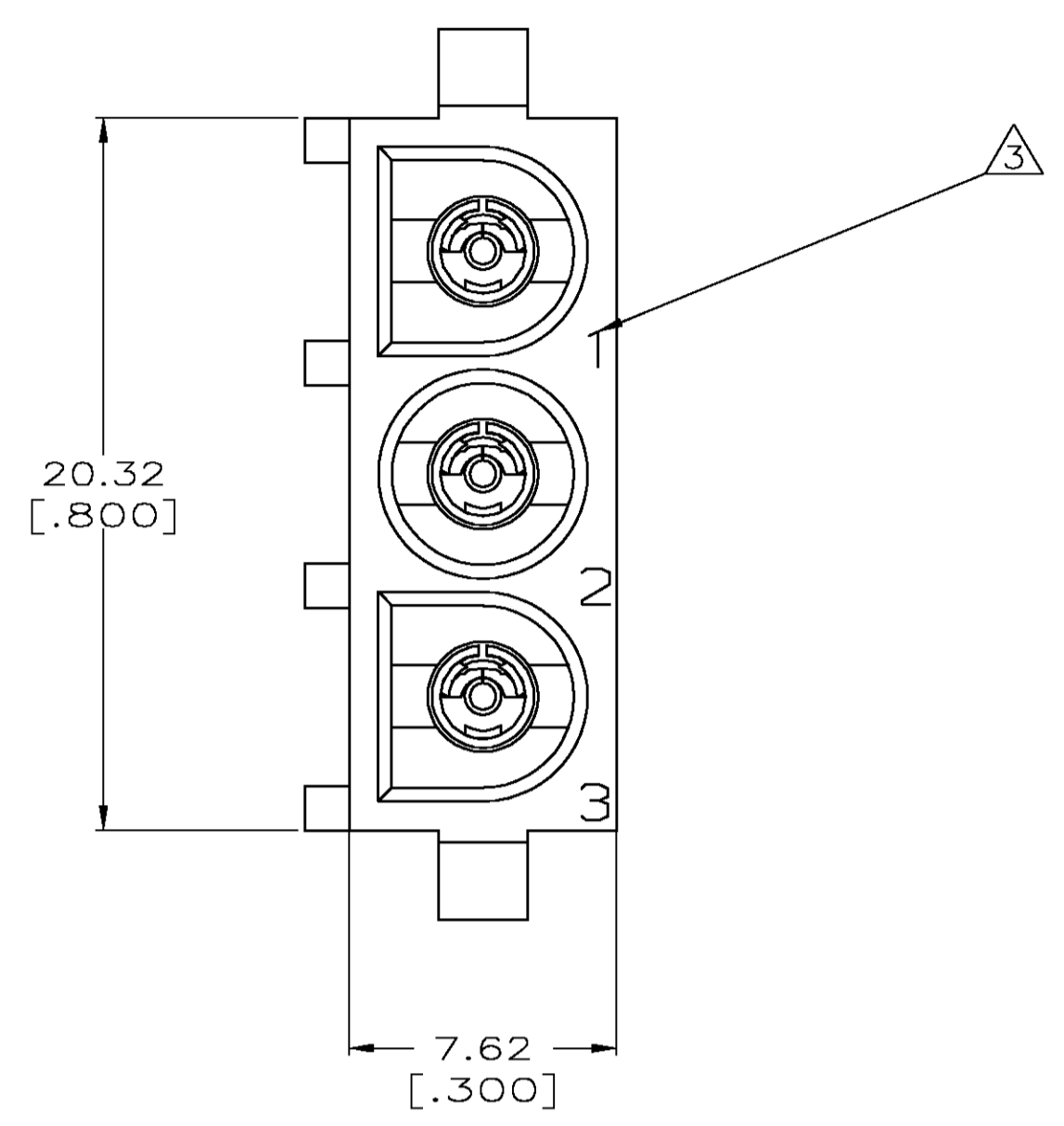

- PARTS COMPLY TO AMP SOLDERABILITY SPECIFICATION 109-11-3.
- CONTACT IS PLATED OVERALL WITH 0.00127 [.000050] NICKEL, THEN 0.00076 [.000030] GOLD OVER CONTACT LENGTH INDICATED AND MATTE TIN LEAD ON SOLDER TAIL END.
- CIRCUIT IDENTIFICATION CHARACTERS ARE ADJACENT TO THE INDICATED CAVITIES, BUT LOCATION AND ORIENTATION MAY DIFFER FROM PRINT.
- DIMENSIONS IN BRACKETS ARE IN INCHES.
- CONTACT IS PLATED OVERALL WITH 0.00127 [.000050] NICKEL, THEN 0.00076 [.000030] GOLD OVER CONTACT LENGTH INDICATED AND MATTE TIN ON SOLDER TAIL END.

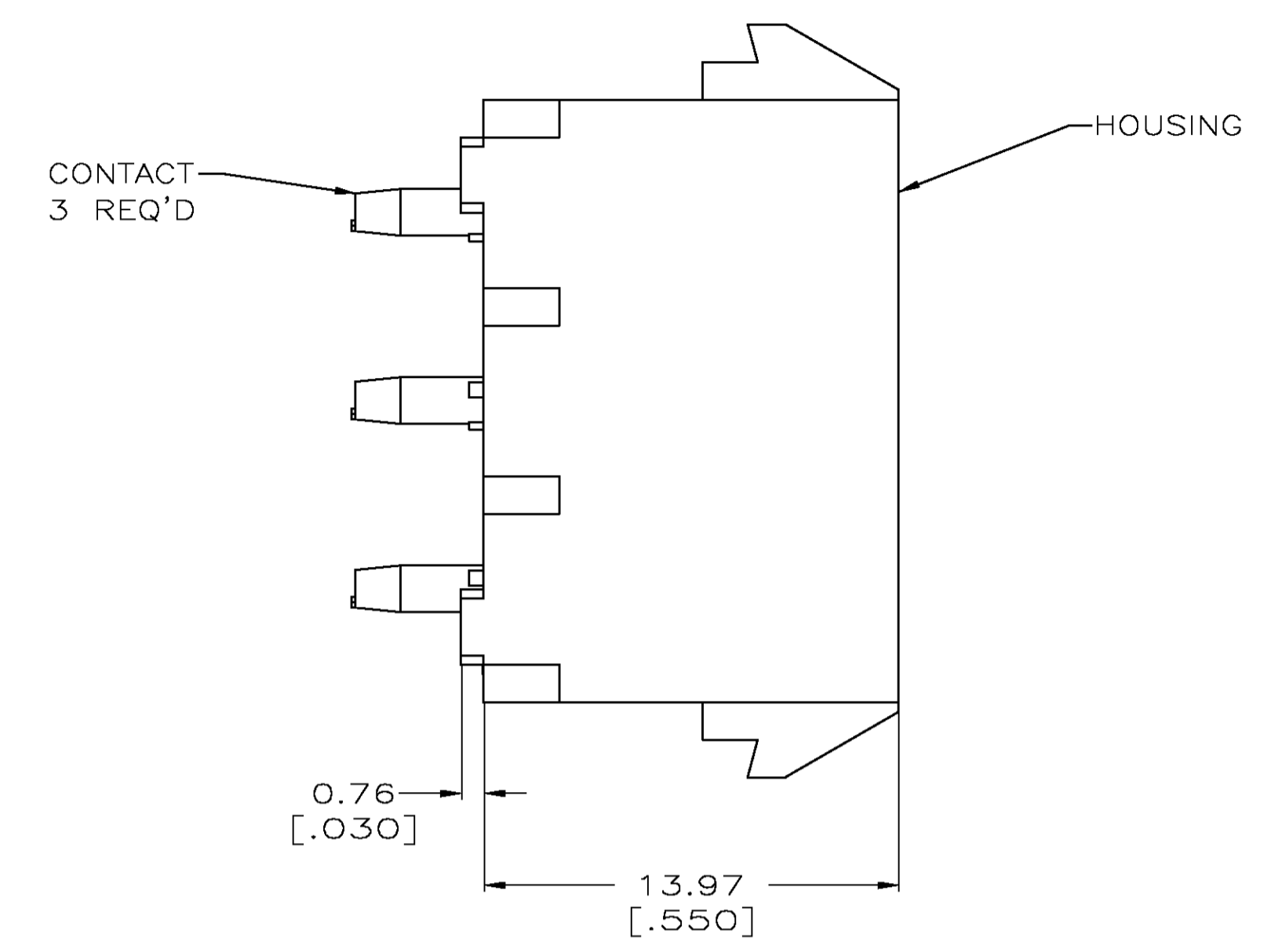
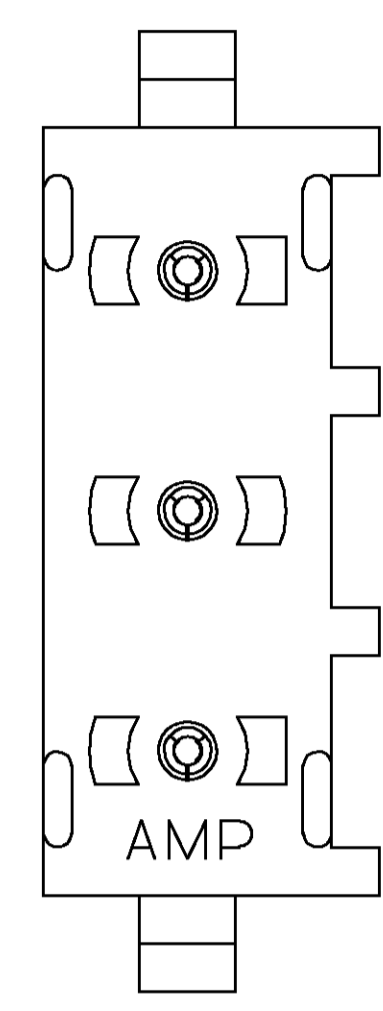
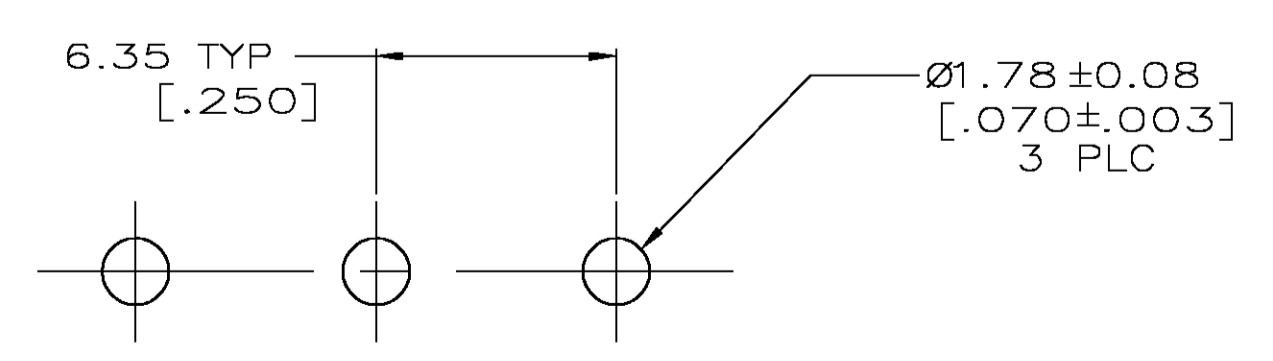
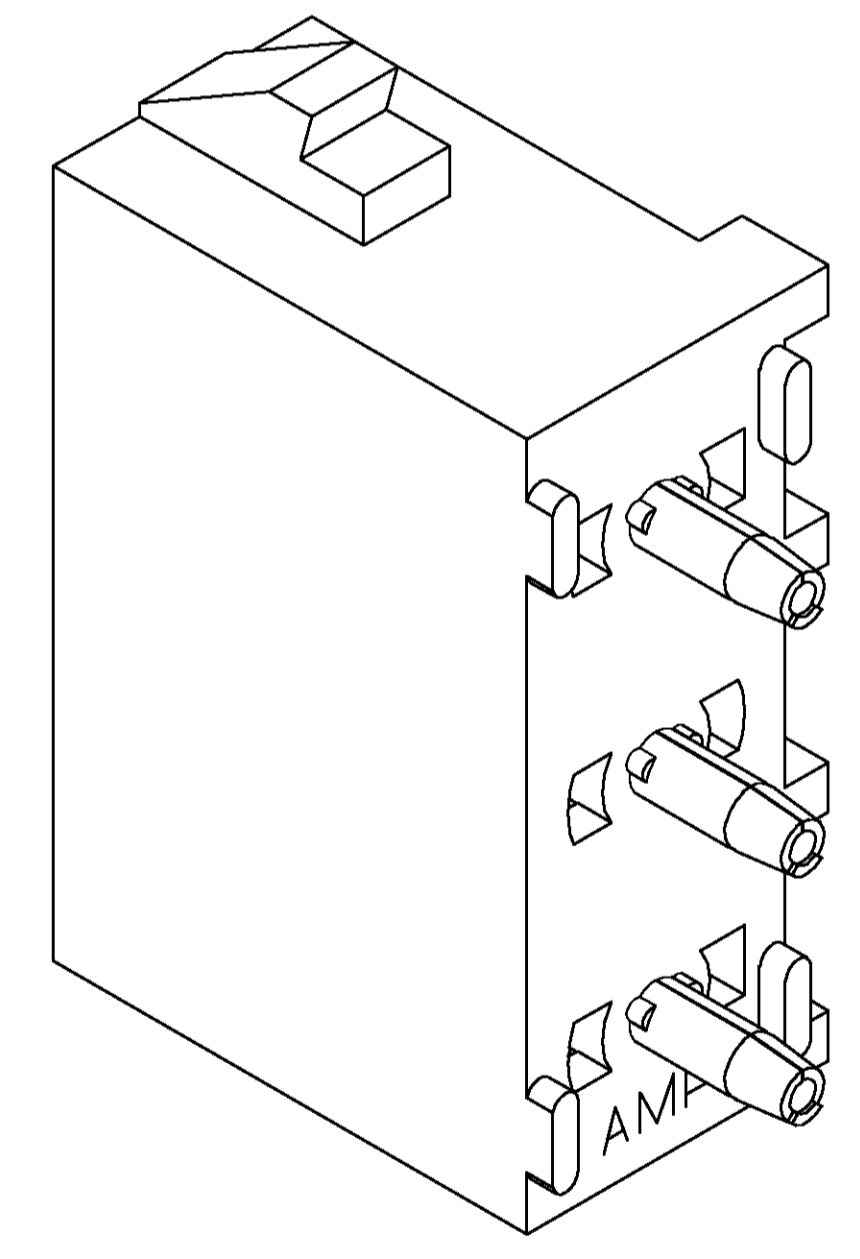
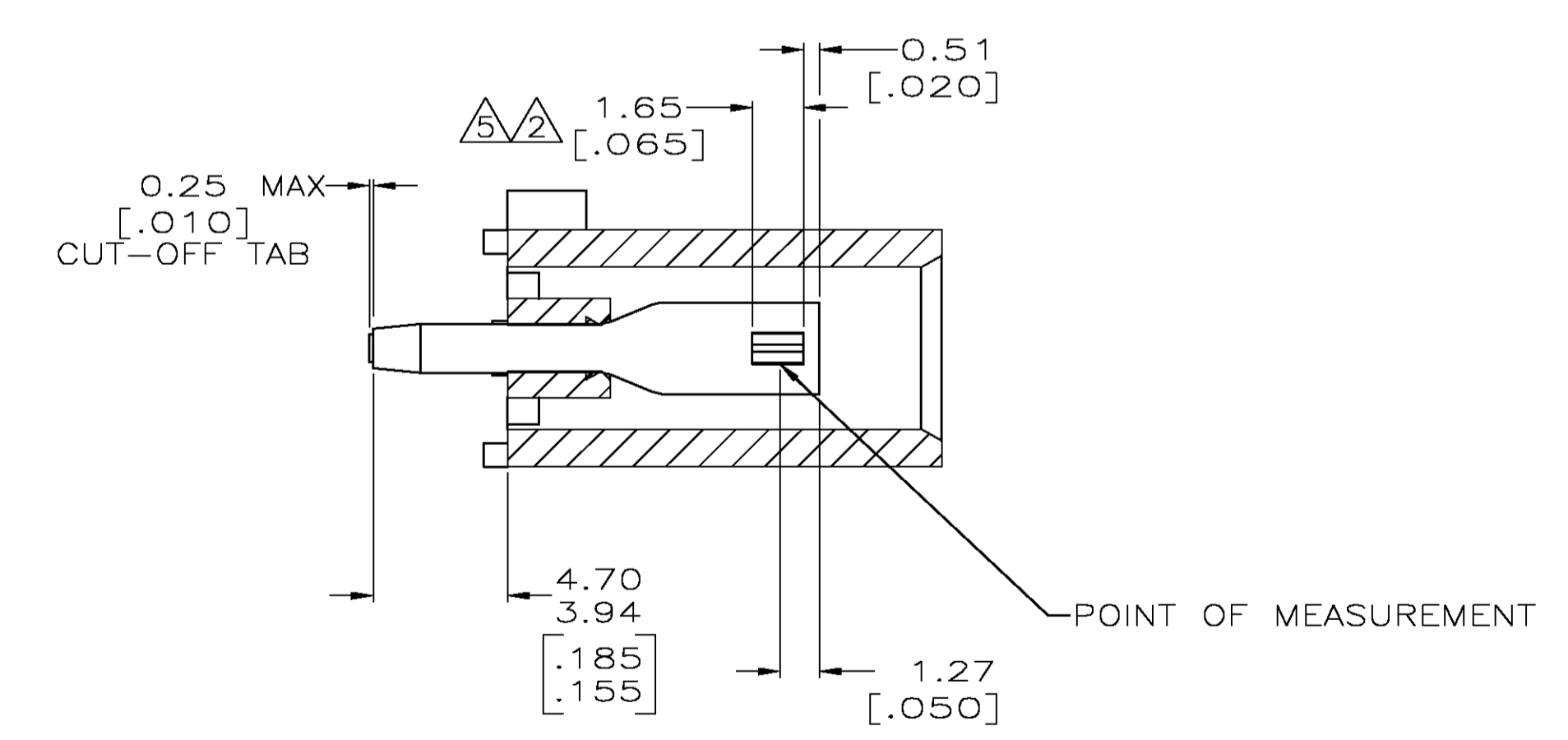

PHOSPHOR BRONZE, GOLD	NYLON, UL94V-2, NATURAL	350760-5
PHOSPHOR BRONZE, PRE-TIN	NYLON, UL94V-2, NATURAL	350760-4
PHOSPHOR BRONZE, GOLD	NYLON, UL94V-2, NATURAL	350760-3
CONTACT MATERIAL AND FINISH	HOUSING MATERIAL	PART NUMBER

THIS DRAWING IS A CONTROLLED DOCUMENT.		DNW B. LEWIS 8-19-98	Tyco Electronics Corporation Greensboro, NC 27409
DIMENSIONS: mm [INCHES]		CHK R. SWING 8-19-98	APVD M. TRULL 8-19-98
TOLERANCES UNLESS OTHERWISE SPECIFIED:		NAME SOCKET HEADER ASSEMBLY, 3 CIRCUIT UNIVERSAL MATE-N-LOK™	
0 PLC ± -	1 PLC ± -	APPLICATION SPEC	SIZE A1
2 PLC ± 0.13 [.005]	3 PLC ± -	WEIGHT	CAGE CODE 00779
4 PLC ± -	ANGLES ± 0.30°	FINISH	DRAWING NO. 350760
MATERIAL SEE TABLE	FINISH SEE TABLE	CUSTOMER DRAWING	RESTRICTED TO
SCALE 5:1		SHEET 1 OF 1	REV T

