

CJ3134K-HF

**N-Channel
RoHS Device
Halogen Free**

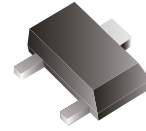

V(BR) _{DSS}	R _{DS(ON)} MAX	I _D
20V	380mΩ@4.5V	0.75A
	450mΩ@2.5V	
	800mΩ@1.8V	

Features

- Lead free product is acquired
- Surface mount package
- N-Channel switch with low R_{DS(on)}
- Operated at low logic level gate drive

Mechanical data

- Case: SOT-723, molded plastic.
- Terminals: Solderable per MIL-STD-750, method 2026.

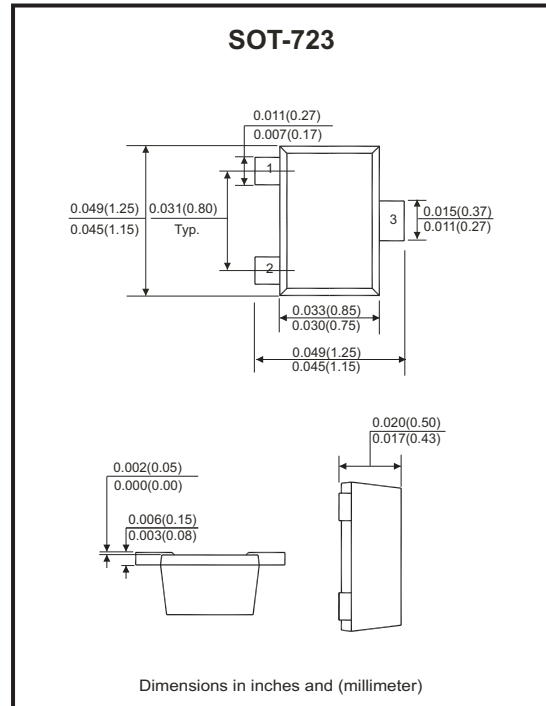

Circuit Diagram

1. G : Gate
2. S : Source
3. D : Drain

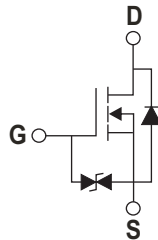

Maximum Rating (at TA=25°C unless otherwise noted)

Parameter	Symbol	Value	Unit
Drain-Source voltage	V _{DS}	20	V
Typical Gate-Source voltage	V _{GS}	±12	V
Continuous drain current (note1)	I _D	0.75	A
Pulsed drain current (tp=10μs)	I _{DM}	1.8	
Power dissipation (note1)	P _D	150	mW
Thermal resistance from junction to ambient (note1)	R _{ΘJA}	833	°C/W
Junction temperature	T _J	150	°C
Storage temperature	T _{STG}	-55 to +150	°C
Lead temperature for soldering purposes (1/8" from case for 10 s)	T _L	260	°C

Notes: 1. Surface mounted on FR4 board using the minimum recommended pad size.

Company reserves the right to improve product design, functions and reliability without notice.

Electrical Characteristics (at $T_A=25^{\circ}\text{C}$ unless otherwise noted)

Parameter	Symbol	Conditions	Min	Typ	Max	Unit
Static Characteristics						
Drain-source breakdown voltage	$V_{(BR)DSS}$	$V_{GS}=0V, I_D=250\mu A$	20			V
Zero gate voltage drain current	I_{DSS}	$V_{DS}=20V, V_{GS}=0V$			1	μA
Gate-body leakage current	I_{GSS}	$V_{GS}=\pm 10V, V_{DS}=0V$			± 20	μA
Gate threshold voltage (note 2)	$V_{GS(th)}$	$V_{DS}=V_{GS}, I_D=250\mu A$	0.35	0.54	1.1	V
Drain-source on-state resistance (note 2)	$R_{DS(on)}$	$V_{GS}=4.5V, I_D=0.65A$		270	380	m Ω
		$V_{GS}=2.5V, I_D=0.55A$		320	450	
		$V_{GS}=1.8V, I_D=0.45A$		390	800	
Forward transconductance (note 2)	g_{FS}	$V_{DS}=10V, I_D=0.8A$		1.6		S
Diode forward voltage	V_{SD}	$I_S=0.15A, V_{GS}=0V$			1.2	V
Dynamic Characteristics (note 4)						
Input capacitance	C_{iss}	$V_{DS}=16V, V_{GS}=0V, f=1MHz$		79	120	pF
Output capacitance	C_{oss}			13	20	
Reverse transfer capacitance	C_{rss}			9	15	
Switching Characteristics (note 4)						
Turn-on delay time (note 3)	$t_{d(on)}$	$V_{GS}=4.5V, V_{DS}=10V$ $I_D=500mA, R_{GEN}=10\Omega$		6.7		nS
Turn-on rise time (note 3)	t_r			4.8		
Turn-off delay time (note 3)	$t_{d(off)}$			17.3		
Turn-off fall time (note 3)	t_f			7.4		

Notes:

1. Surface mounted on FR4 board using the minimum recommended pad size.
2. Pulse test: Pulse width=300 μs , Duty cycle=2%
3. Switching characteristics are independent of operating junction temperatures.
4. Guaranteed by design, not subject to producing.

RATING AND CHARACTERISTIC CURVES (CJ3134K-HF)

Fig.1 - Output Characteristics

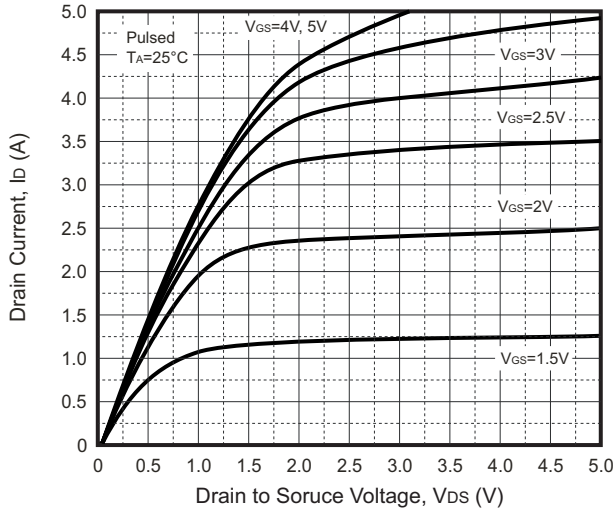

Fig.2 - Transfer Characteristics

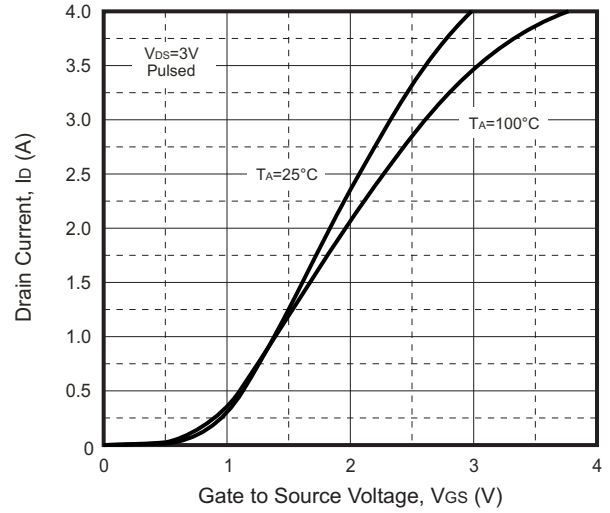

Fig.3 - $R_{DS(ON)}$ — I_D

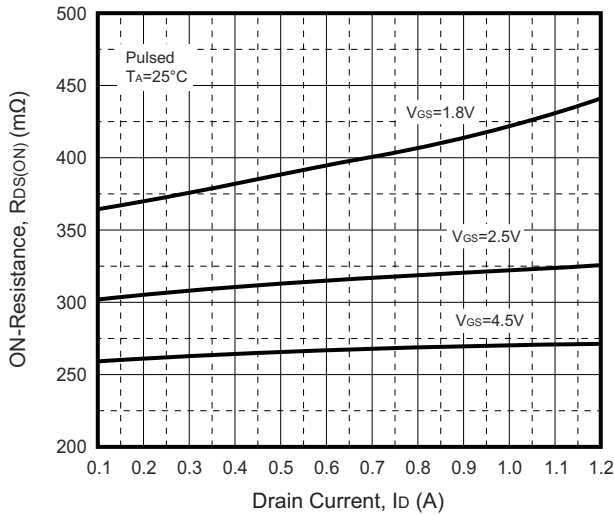

Fig.4 - $R_{DS(ON)}$ — V_{GS}

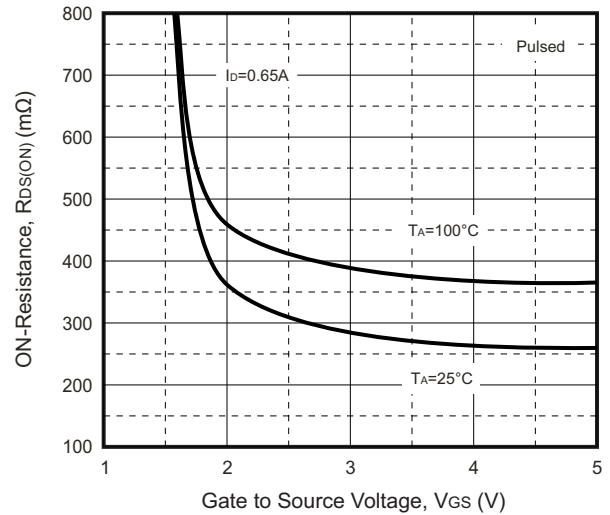

Fig.5 - I_S — V_{SD}

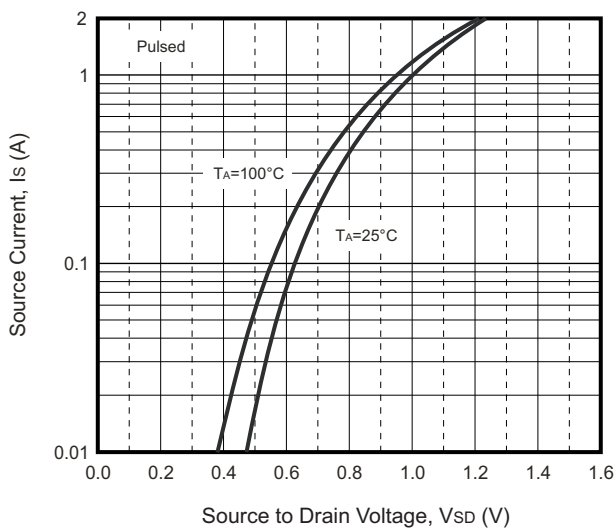
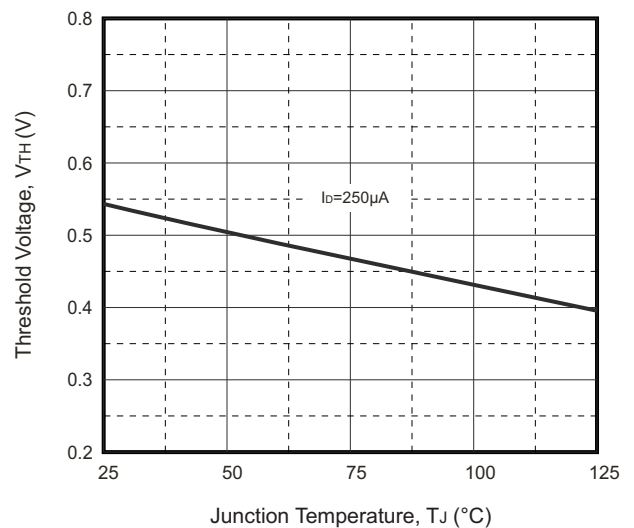
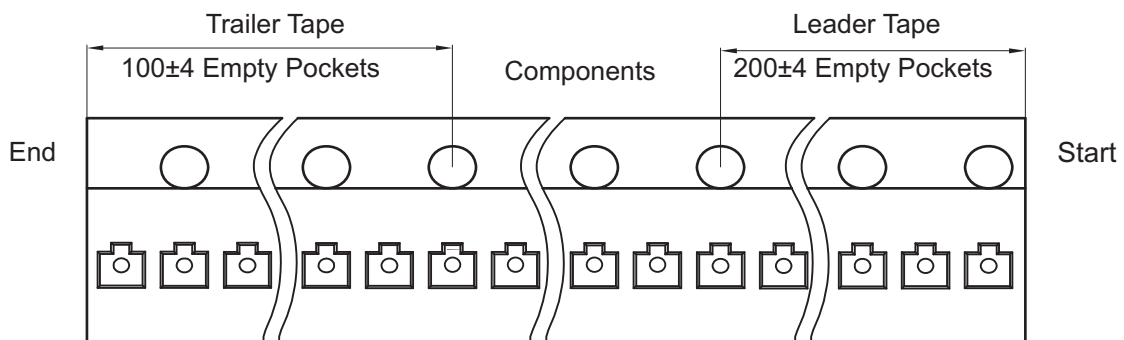
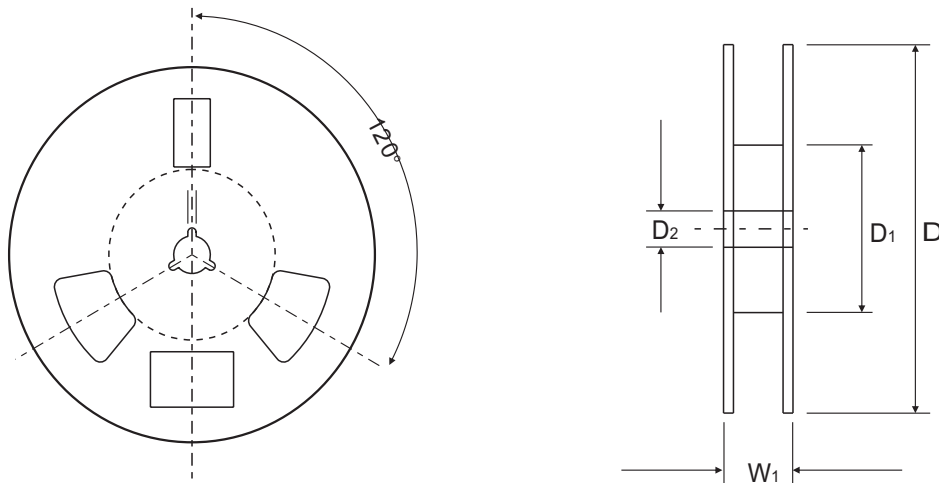
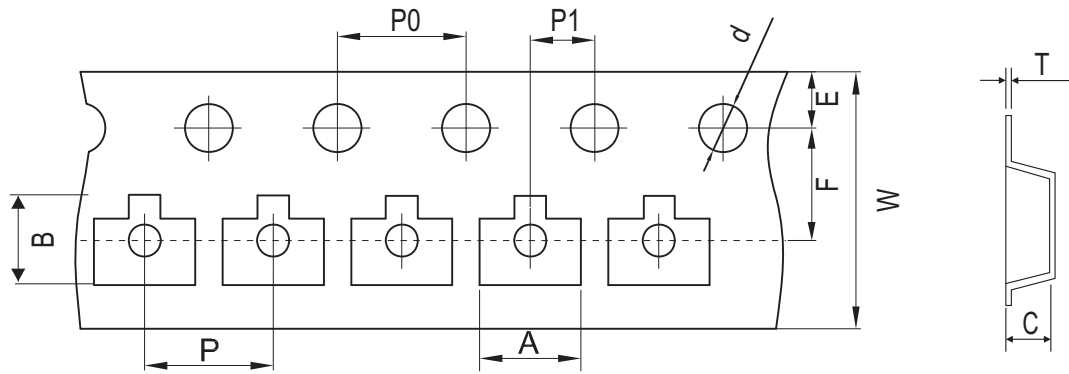

Fig.6 - Threshold Voltage



Company reserves the right to improve product design, functions and reliability without notice.

Reel Taping Specification



SOT-723	SYMBOL	A	B	C	d	D	D1	D2
	(mm)	1.33 ± 0.05	1.45 ± 0.05	0.61 ± 0.05	1.50 ± 0.10	178 ± 2.00	54.40 ± 1.00	13.00 ± 1.00
	(inch)	0.052 ± 0.002	0.057 ± 0.002	0.024 ± 0.002	0.059 ± 0.004	7.008 ± 0.078	2.142 ± 0.039	0.512 ± 0.039

SOT-723	SYMBOL	E	F	P	P0	P1	W	W1
	(mm)	1.75 ± 0.10	3.50 ± 0.05	2.00 ± 0.10	4.00 ± 0.10	2.00 ± 0.10	8.00 + 0.30 / - 0.10	12.30 ± 1.00
	(inch)	0.069 ± 0.004	0.138 ± 0.002	0.079 ± 0.004	0.158 ± 0.004	0.079 ± 0.004	0.315 + 0.012 / - 0.004	0.484 ± 0.039

Company reserves the right to improve product design , functions and reliability without notice.

Marking Code

Part Number	Marking Code
CJ3134K-HF	KF

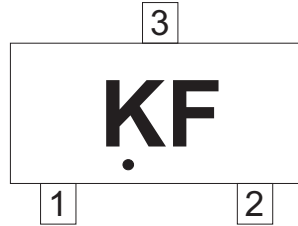

Solid dot “•” = Halogen Free

Suggested PAD Layout

SIZE	SOT-723	
	(mm)	(inch)
A	0.42	0.017
B	0.30	0.012
C	0.30	0.012
D	0.32	0.013
E	0.80	0.031
F	1.00	0.039

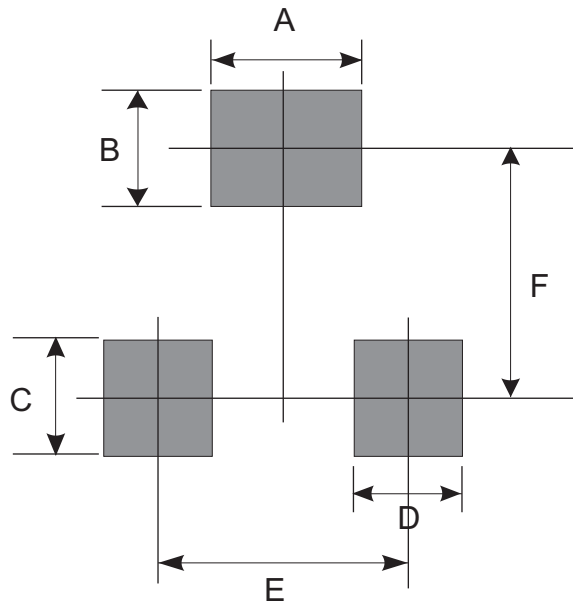

Note:

- 1.General tolerance: $\pm 0.05\text{mm}$.
- 2.The pad layout is for reference purposes only.

Standard Packaging

Case Type	REEL PACK	
	REEL (pcs)	Reel Size (inch)
SOT-723	8,000	7