

CTS2030N3-HF (NPN)

RoHS Device
Halogen Free

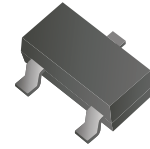

Features

- High breakdown voltage, $BV_{CEO} \geq 200V$.
- Large continuous collector current capability.
- Low collector saturation voltage.

Diagram

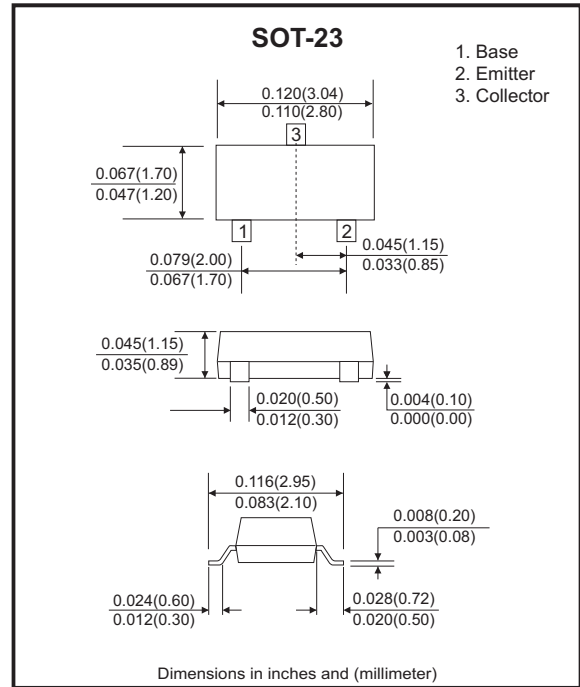
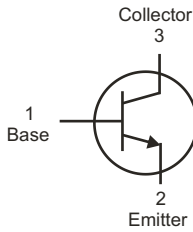

Maximum Ratings (at $T_A=25^\circ C$ unless otherwise noted)

Parameter	Symbol	Value	Units
Collector-Base voltage	V_{CBO}	280	V
Collector-Emitter voltage	V_{CEO}	200	V
Emitter-Base voltage	V_{EBO}	6	V
Collector current	I_C	1	A
Base current	I_B	0.5	A
Power dissipation ($T_A=25^\circ C$, Note 1)	P_D	225	mW
Power dissipation ($T_C=25^\circ C$)	P_D	560	mW
Thermal resistance, junction to ambient (Note 1)	$R_{\theta JA}$	556	$^\circ C/W$
Thermal resistance, junction to case	$R_{\theta JC}$	223	$^\circ C/W$
Junction temperature	T_J	150	$^\circ C$
Storage temperature range	T_{STG}	-55 to +150	$^\circ C$

Notes:
1. Free air condition

Company reserves the right to improve product design, functions and reliability without notice.

Electrical Characteristics (at $T_A=25^\circ\text{C}$ unless otherwise noted)

Parameter	Symbol	Conditions	Min.	Typ.	Max.	Units
Collector-Base breakdown voltage	$V_{(BR)CBO}$	$I_C=100\mu\text{A}$, $I_E=0$	280	-	-	V
Collector-Emitter breakdown voltage	$V_{(BR)CEO}$	$I_C=10\text{mA}$, $I_B=0$	200	-	-	V
Emitter-Base breakdown voltage	$V_{(BR)EBO}$	$I_E=10\mu\text{A}$, $I_C=0$	6	-	-	V
Collector cut-off current	I_{CBO}	$V_{CB}=250\text{V}$, $I_E=0$		-	100	nA
Emitter cut-off current	I_{EBO}	$V_{EB}=6\text{V}$, $I_C=0$	-	-	100	nA
DC current gain (Note 1)	$h_{FE(1)}$	$V_{CE}=5\text{V}$, $I_C=1\text{mA}$	100	-	-	
	$h_{FE(2)}$	$V_{CE}=5\text{V}$, $I_C=0.2\text{A}$	100	-	320	
	$h_{FE(3)}$	$V_{CE}=5\text{V}$, $I_C=1\text{A}$	10	-	-	
Collector-Emitter saturation voltage (Note 1)	$V_{CE(sat)1}$	$I_C=100\text{mA}$, $I_B=10\text{mA}$	-	-	0.1	V
	$V_{CE(sat)2}$	$I_C=250\text{mA}$, $I_B=25\text{mA}$	-	-	0.2	V
	$V_{CE(sat)3}$	$I_C=500\text{mA}$, $I_B=50\text{mA}$	-	0.2	0.5	V
Base-Emitter saturation voltage (Note 1)	$V_{BE(sat)}$	$I_C=250\text{mA}$, $I_B=25\text{mA}$	-	-	0.95	V
Base-Emitter on voltage (Note 1)	$V_{BE(on)}$	$I_C=250\text{mA}$, $V_{CE}=5\text{V}$	-	-	0.9	V
Output capacitance	C_{ob}	$V_{CB}=10\text{V}$, $I_E=0\text{A}$, $f=1\text{MHz}$	-	-	10	pF
Transition frequency	f_T	$V_{CE}=10\text{V}$, $I_C=50\text{mA}$ $f=100\text{MHz}$	75	-	-	MHz

Notes:

1. Pulse test: Pulse Width $\leq 380\mu\text{s}$, Duty Cycle $\leq 2\%$.

RATING AND CHARACTERISTIC CURVES (CTS2030N3-HF)

Fig.1 - Power Derating Curve

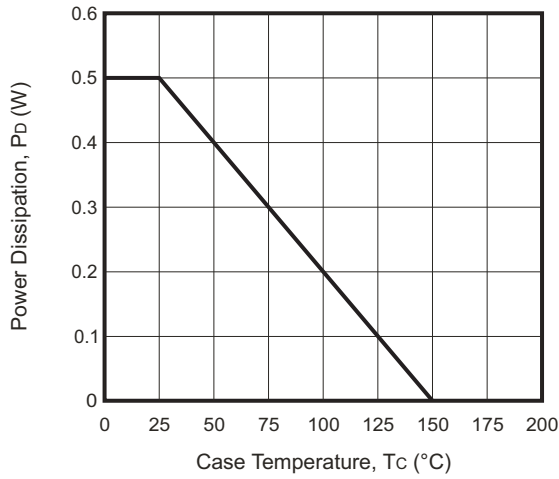

Fig.2 - Saturation Voltage vs. Collector Current

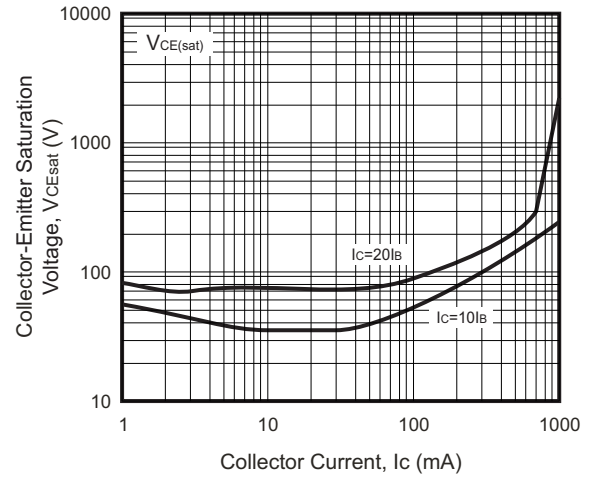

Fig.3 - Saturation Voltage vs. Collector Current

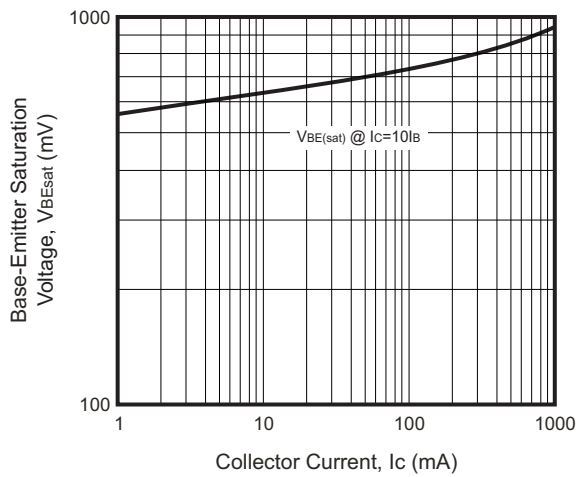
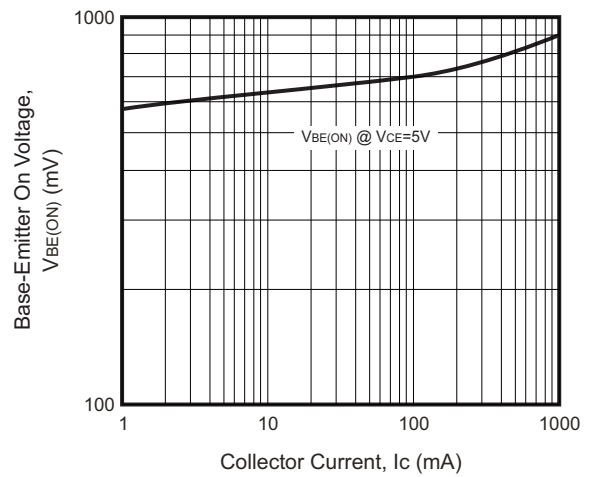
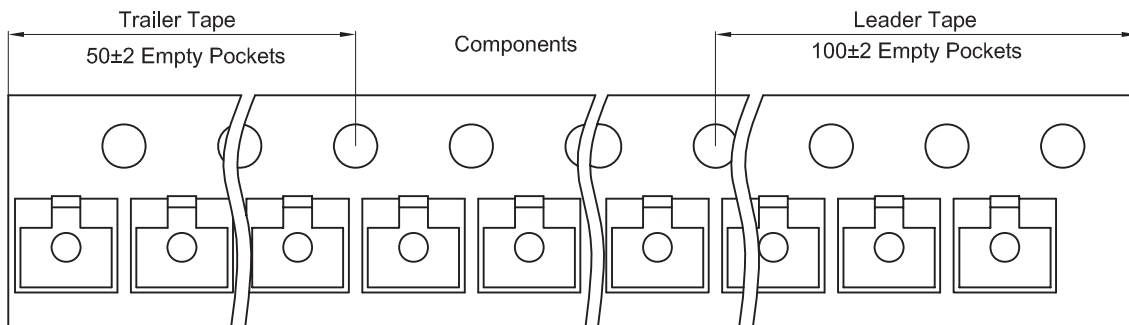
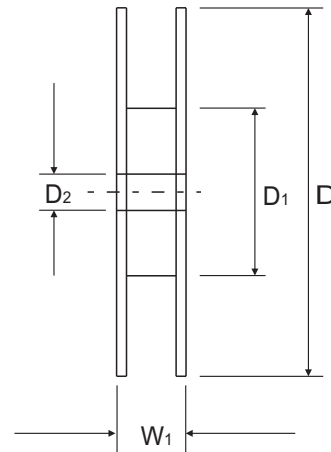
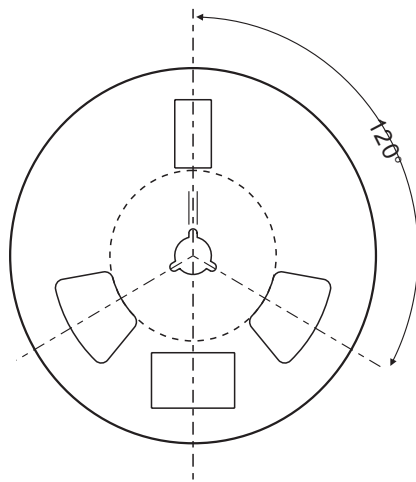
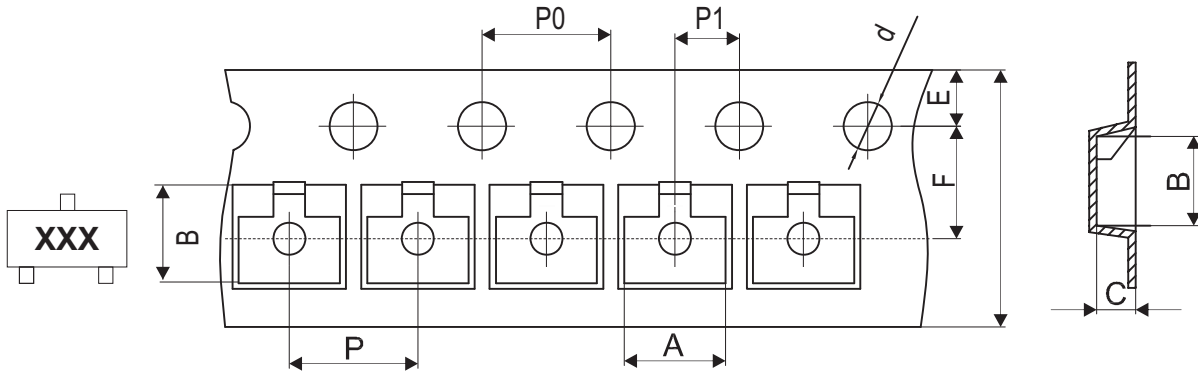

Fig.4 - On Voltage vs. Collector Current



Reel Taping Specification



SOT-23	SYMBOL	A	B	C	d	D	D1	D2
	(mm)	3.17 ± 0.10	3.23 ± 0.10	1.37 ± 0.10	1.50 ± 0.10	178.00 ± 1.00	55.00 ± 1.00	13.00 ± 0.50
	(inch)	0.125 ± 0.004	0.127 ± 0.004	0.054 ± 0.004	0.059 ± 0.004	7.008 ± 0.039	2.165 ± 0.039	0.512 ± 0.020

SOT-23	SYMBOL	E	F	P	P0	P1	W	W1
	(mm)	1.75 ± 0.10	3.50 ± 0.05	4.00 ± 0.10	4.00 ± 0.10	2.00 ± 0.05	8.00 + 0.30 / - 0.10	12.00 ± 0.50
	(inch)	0.069 ± 0.004	0.138 ± 0.002	0.157 ± 0.004	0.157 ± 0.004	0.079 ± 0.002	0.315 + 0.012 / - 0.004	0.472 ± 0.020

Company reserves the right to improve product design, functions and reliability without notice.

REV: A

Marking Code

Part Number	Marking Code
CTS2030N3-HF	CB

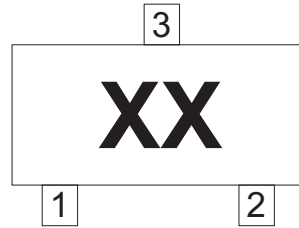

xx = Product type marking code

Suggested PAD Layout

SIZE	SOT-23	
	(mm)	(inch)
A	0.90	0.035
B	0.80	0.031
C	0.95	0.037
D	2.00	0.079

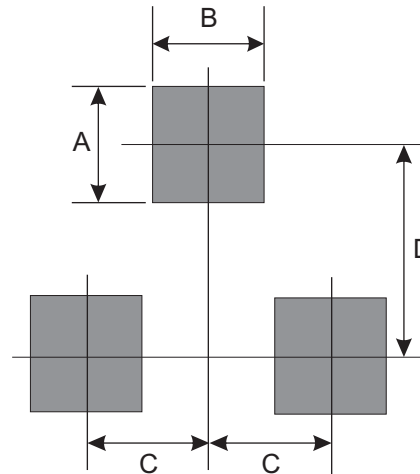

Note: The pad layout is for reference purposes only.

Standard Packaging

Case Type	REEL PACK	
	REEL (pcs)	Reel Size (inch)
SOT-23	3,000	7