

Chip Schottky Barrier Rectifier



SMD Diodes Specialist

CDBD1020-G Thru. CDBD10200-G

Reverse Voltage: 20 to 200 Volts

Forward Current: 10.0 Amp

RoHS Device

Features

- Batch process design, excellent power dissipation offers better reverse leakage current and thermal resistance.
- Low profile surface mounted application in order to optimize board space.
- Low power loss, high efficiency.
- High current capability, low forward voltage drop.
- High surge capability.
- Guardring for overvoltage protection.
- Ultra high-speed switching.
- Silicon epitaxial planar chip, metal silicon junction.
- Lead-free parts meet environmental standards of MIL-STD-19500 /228

Mechanical data

- Case: TO-263/D2PAK, molded plastic.
- Terminals: solderable per MIL-STD-750, method 2026.
- Polarity: Indicated by cathode band.
- Weunting Position: Any
- Weight: 1.70 gram(approx.).

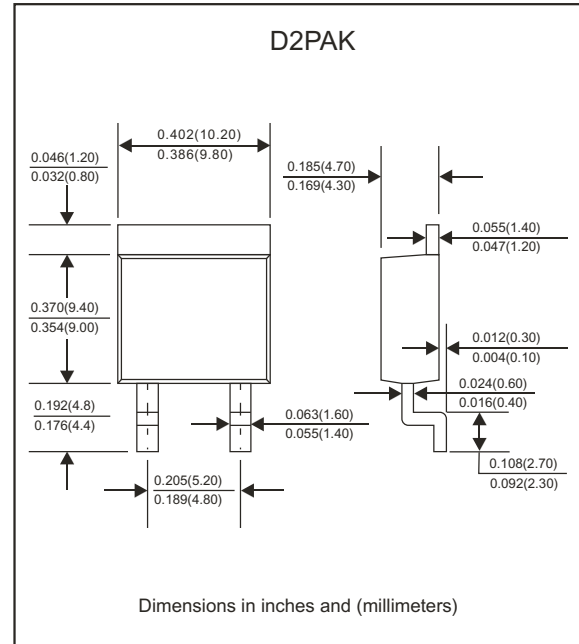

Maximum Ratings (At Ta=25°C, unless otherwise noted)

Parameter	Symbol	CDBD 1020-G	CDBD 1030-G	CDBD 1040-G	CDBD 1050-G	CDBD 1060-G	CDBD 1080-G	CDBD 10100-G	CDBD 10150-G	CDBD 10200-G	Unit	
Repetitive peak reverse voltage	V_{RRM}	20	30	40	50	60	80	100	150	200	V	
Continuous reverse voltage	V_R	20	30	40	50	60	80	100	150	200	V	
RMS voltage	V_{RMS}	14	21	28	35	42	56	70	105	140	V	
Forward rectified current (See fig. 1)	I_o	10.0									A	
Maximum forward voltage $I_F=10.0A$	V_F	0.55			0.75		0.85		1.00		V	
Forward surge current, 8.3ms single half sine-wave superimposed on rated load (JEDEC method)	I_{FSM}	150									A	
Reverse current	$V_R=V_{RRM}$ $T_A=25^\circ C$	0.5									mA	
	$V_R=V_{RRM}$ $T_A=100^\circ C$	50									mA	
Thermal resistance Junction to Case	$R_{\theta Jc}$	3.0									$^\circ C/W$	
Operating temperature	T_J	-55 to +125				-55 to +125						$^\circ C$
Storage temperature	T_{STG}	-65 to +175									$^\circ C$	

RATING AND CHARACTERISTIC CURVES (CDBD1020-G Thru. CDBD10200-G)

FIG.1-TYPICAL FORWARD CURRENT DERATING CURVE

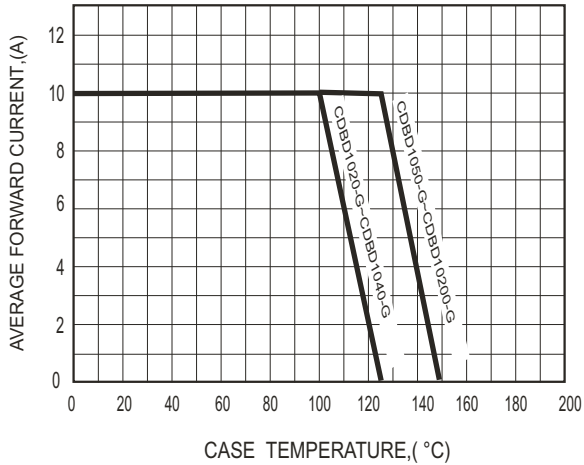

FIG.2-TYPICAL FORWARD CHARACTERISTICS

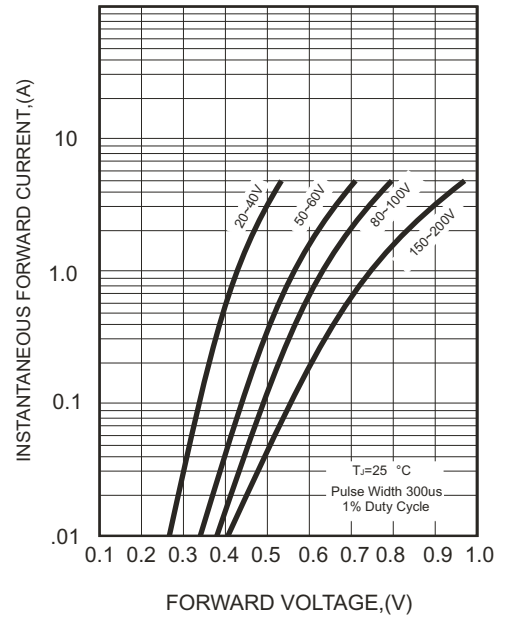

FIG.3-MAXIMUM NON-REPETITIVE FORWARD SURGE CURRENT

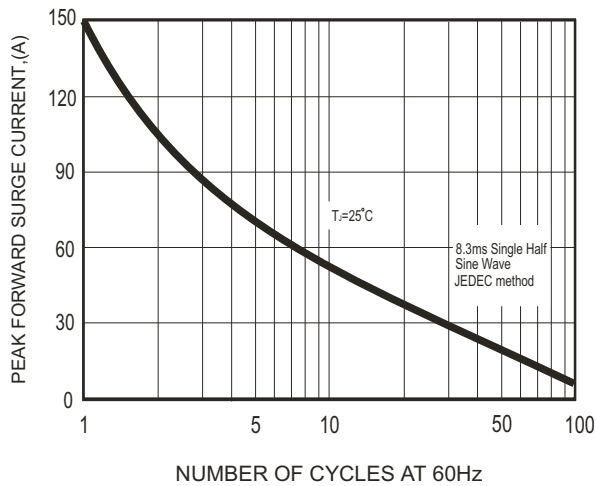
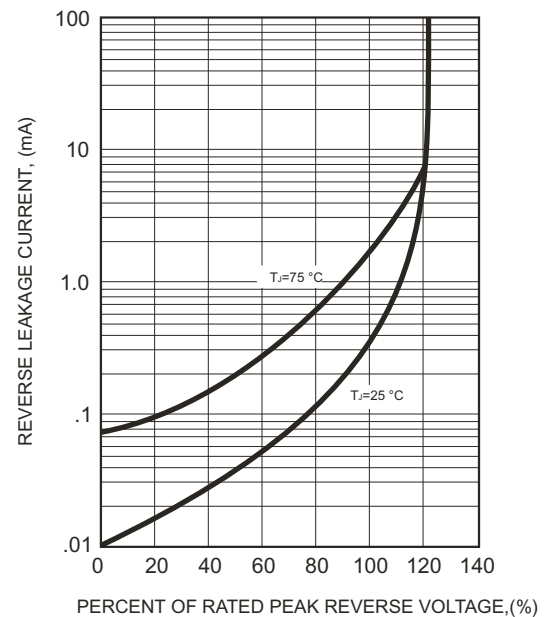
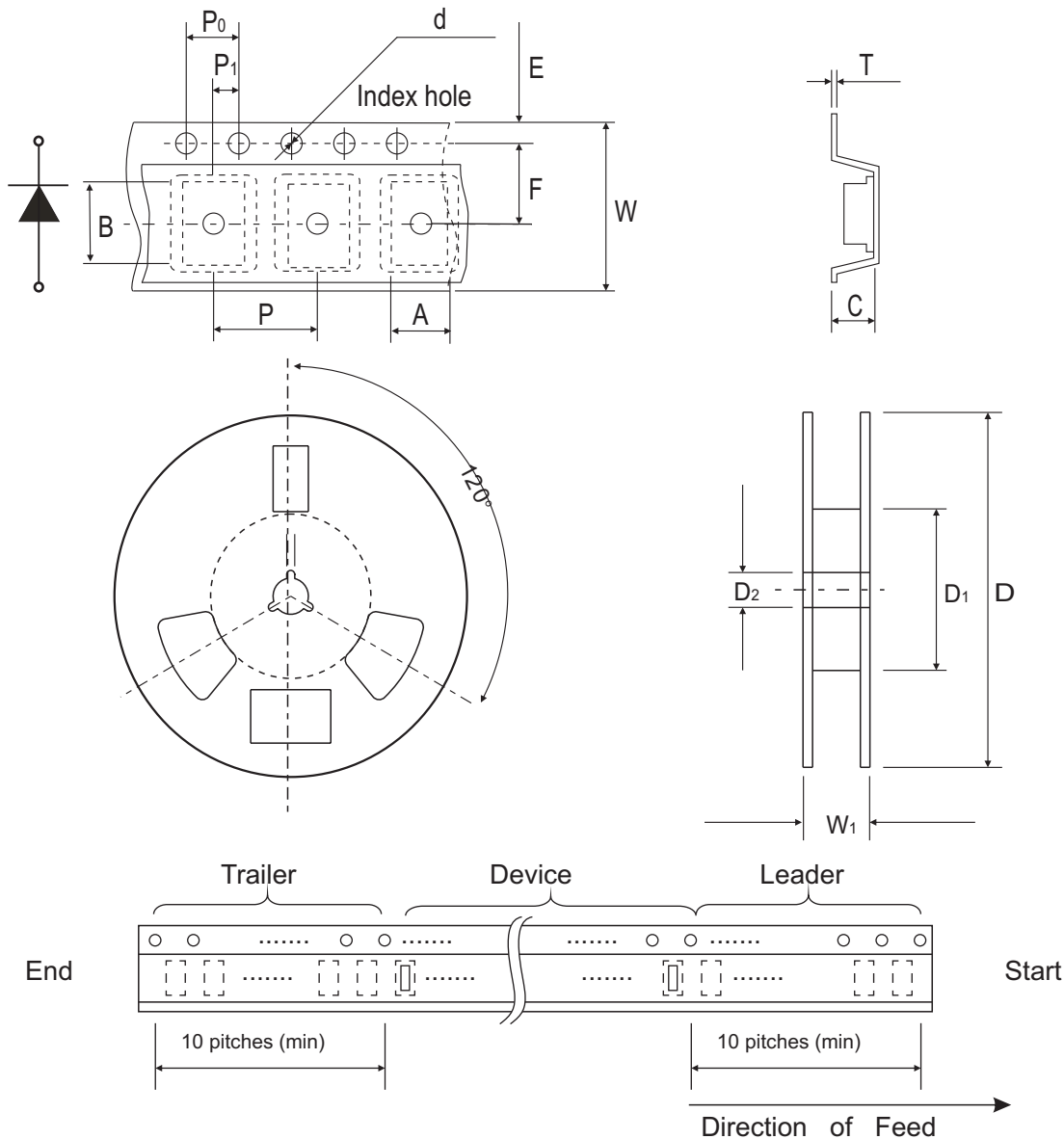

FIG.4 - TYPICAL REVERSE CHARACTERISTICS



Reel Taping Specification



TO-263/D2PAK	SYMBOL	A	B	C	d	D	D ₁	D ₂
	(mm)	10.70 ± 0.10	16.30 ± 0.10	5.10 ± 0.10	1.50 ± 0.10	330.00 ± 2.00	50.0 MIN.	13.0 ± 0.50
	(inch)	0.421 ± 0.004	0.642 ± 0.004	0.201 ± 0.004	0.059 ± 0.004	13.00 ± 0.079	1.969 MIN.	0.512 ± 0.020

TO-263/D2PAK	SYMBOL	E	F	P	P ₀	P ₁	T	W	W ₁
	(mm)	1.75 ± 0.10	11.50 ± 0.10	16.00 ± 0.10	4.00 ± 0.10	2.00 ± 0.10	0.23 ± 0.10	24.00 ± 0.30	30.00 ± 1.0
	(inch)	0.069 ± 0.004	0.453 ± 0.004	0.630 ± 0.004	0.157 ± 0.004	0.079 ± 0.004	0.009 ± 0.004	0.945 ± 0.012	1.181 ± 0.039

Marking Code

Part Number	Marking Code
CDBD1020-G	SK1020
CDBD1030-G	SK1030
CDBD1040-G	SK1040
CDBD1050-G	SK1050
CDBD1060-G	SK1060
CDBD1080-G	SK1080
CDBD10100-G	SK10100
CDBD10150-G	SK10150
CDBD10200-G	SK10200

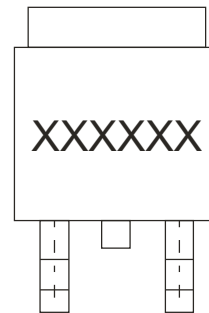

XXXXXX / XXXXXXXX = Product type marking code

Suggested PAD Layout

SIZE	TO-263 / D2PAK	
	(mm)	(inch)
A	9.50	0.347
B	2.50	0.098
C	16.90	0.665
X1	10.80	0.425
X2	1.10	0.043
Y1	11.40	0.449
Y2	3.50	0.138

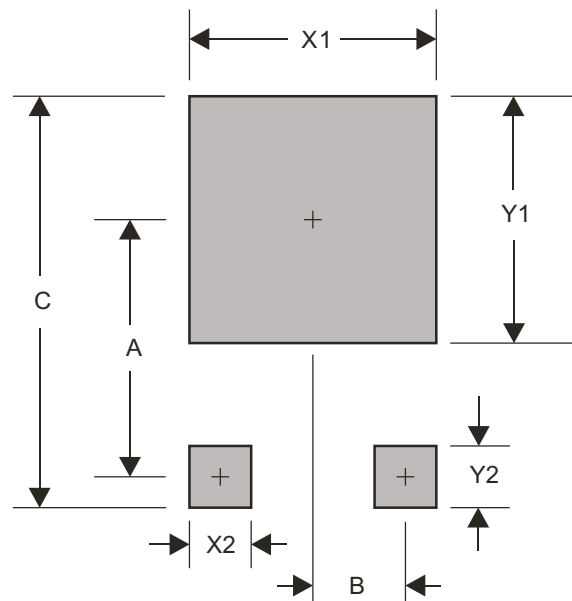

Standard Package

Case Type	Qty per Reel	Reel Size
	(Pcs)	(inch)
TO-263 / D2PAK	800	13