

## TB2S-G Thru. TB10S-G

Reverse Voltage: 200 to 1000 Volts

Forward Current: 0.8, 1.0 A

RoHS Device

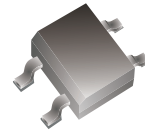

### Features

- Glass passivated chip junction.
- High surge overload rating :30A peak
- Save space on printed circuit boards.
- High temperature soldering guaranteed:  
260°C/10 seconds at 5 lbs.
- Pb free product.
- Plastic material has U/L flammability classification 94v-0.

### Mechanical data

- Polarity: Symbol molded on body.
- Case: Molded plastic body over passivated junction.
- Terminals: Plated leads solderable per MIL-STD-750,  
Method 2026.
- Mounting position: Any.

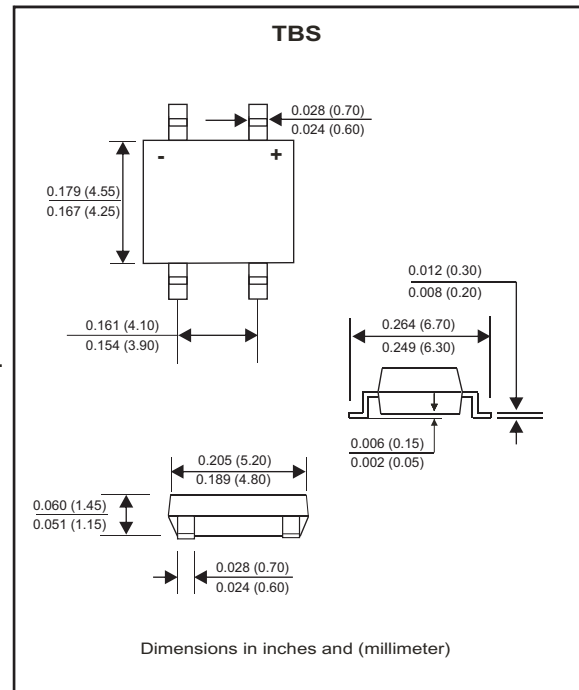

### Maximum Rating And Electrical Characteristics

Rating at  $T_A=25^\circ\text{C}$ , unless otherwise noted.  
Single phase, half wave, 60Hz, resistive or inductive load.  
For capacitive load, derate current by 20%.

Parameter	Symbol	TB2S-G	TB4S-G	TB6S-G	TB8S-G	TB10S-G	Unit
	Marking	TB2S	TB4S	TB6S	TB8S	TB10S	
Maximum Recurrent Peak Reverse Voltage	$V_{RRM}$	200	400	600	800	1000	V
Maximum RMS Voltage	$V_{RMS}$	140	280	420	560	700	V
Maximum DC Blocking Voltage	$V_{DC}$	200	400	600	800	1000	V
Maximum Average Forward Output Current $T_L=100^\circ\text{C}$	$I_{F(AV)}$	0.8 <sup>1)</sup> 1.0 <sup>2)</sup>					A
Peak Forward Surge Current, 8.3ms Single Half Sine-wave, Superimposed on Rated Load (JEDEC Method)	$I_{FSM}$	30					A
Maximum Instantaneous Forward Voltage at 0.4A DC	$V_F$	0.95					V
Maximum Reverse Current @ $T_A=25^\circ\text{C}$ at Rated DC Blocking Voltage	$I_R$	10					$\mu\text{A}$
Typical Thermal Junction to lead On aluminum substrate On glass-epoxy substrate	$R_{\theta JL}$ $R_{\theta JA}$	25 62.5 80					$^\circ\text{C/W}$
Operating Junction Temperature Range	$T_J$	-55 to +150					$^\circ\text{C}$
Storage Temperature Range	$T_{STG}$	-55 to +150					$^\circ\text{C}$

Notes: 1. On glass epoxy P.C.B  
2. On aluminum substrate

## RATING AND CHARACTERISTIC CURVES (TB2S-G thru TB10S-G)

Fig.1-Typical Forward Characteristics

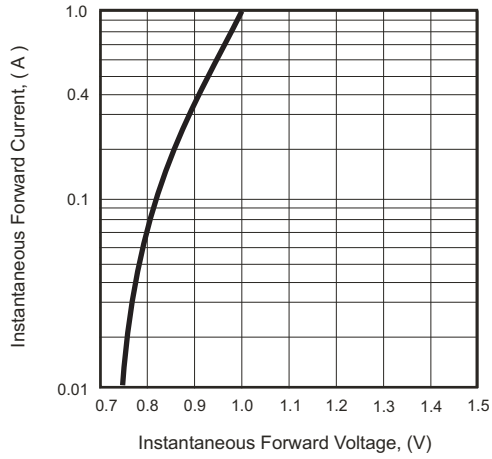

Fig.2-Forward Derating Curve

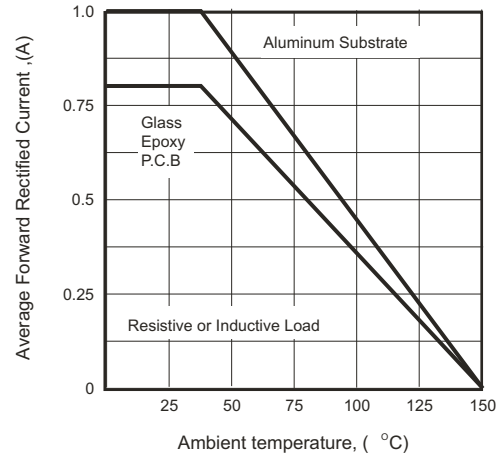

Fig.3-Typical Reverse Characteristics

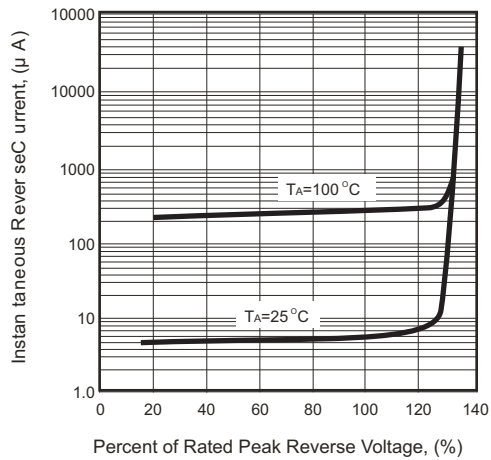
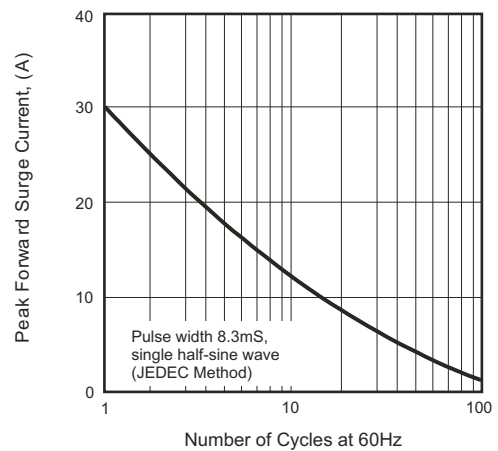
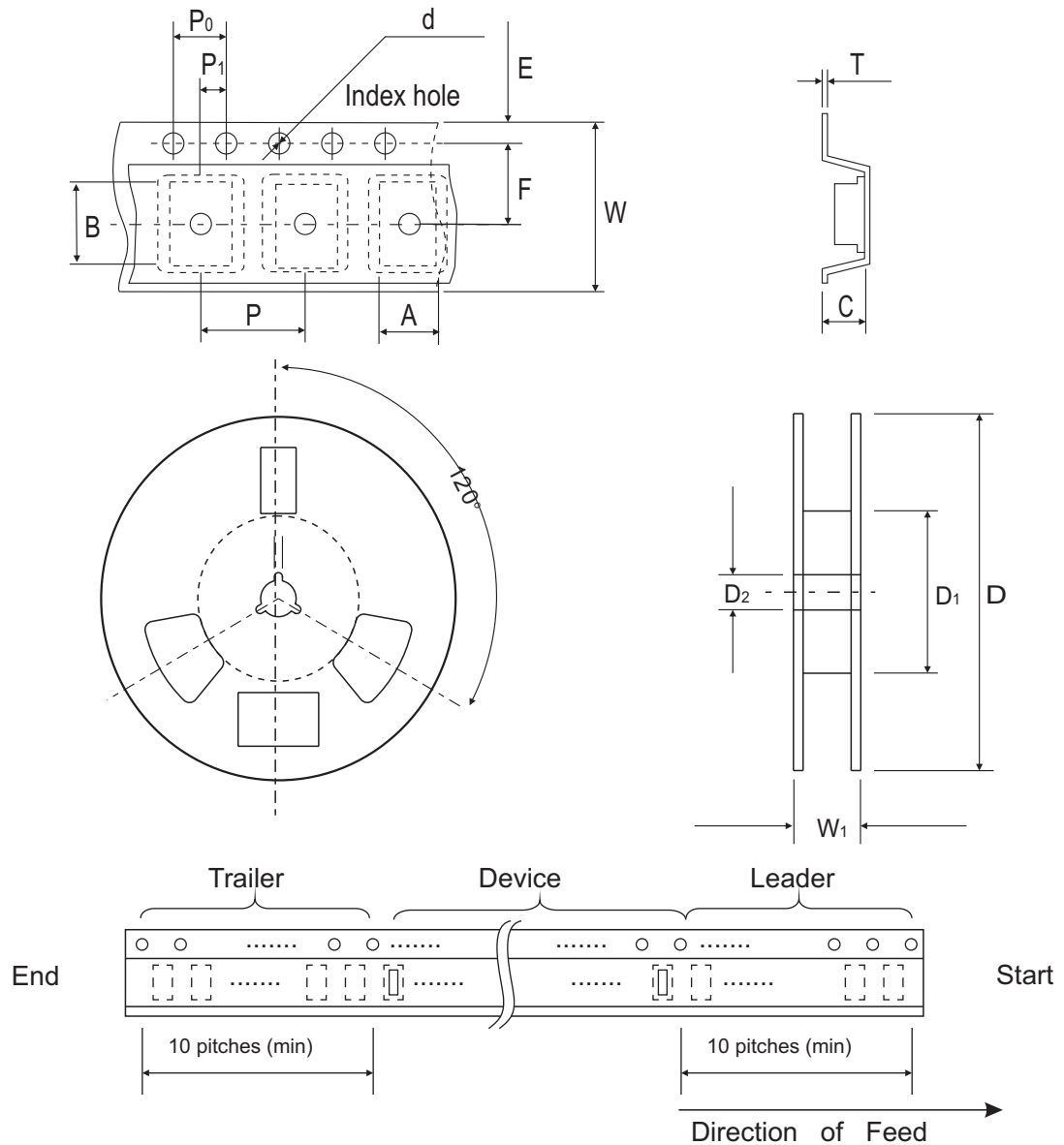

Fig.4- Peak Forward Surge Current



## Reel Taping Specification



TBS	SYMBOL	A	B	C	d	D	D <sub>1</sub>	D <sub>2</sub>
	(mm)	5.50 ± 0.10	6.85 ± 0.10	2.10 ± 0.10	1.55 ± 0.05	330 ± 0.1	75 ± 0.1	13.0 ± 0.10
	(inch)	0.217 ± 0.004	0.270 ± 0.004	0.083 ± 0.004	0.061 ± 0.002	12.992 ± 0.004	2.953 ± 0.004	0.512 ± 0.004

TBS	SYMBOL	E	F	P	P <sub>0</sub>	P <sub>1</sub>	T	W	W <sub>1</sub>
	(mm)	1.75 ± 0.10	5.50 ± 0.10	8.00 ± 0.10	4.00 ± 0.10	2.00 ± 0.05	0.30 ± 0.05	12.00 ± 0.30	18.00 ± 0.1
	(inch)	0.069 ± 0.004	0.217 ± 0.004	0.315 ± 0.004	0.157 ± 0.004	0.079 ± 0.002	0.012 ± 0.002	0.472 ± 0.012	0.709 ± 0.004

## Suggested PAD Layout

SIZE	TBS	
	(mm)	(inch)
A	0.68MIN	0.027MIN
B	4.0±0.1	0.157±0.004
C	0.62MIN	0.024MIN
D	6.70MAX	0.264MAX

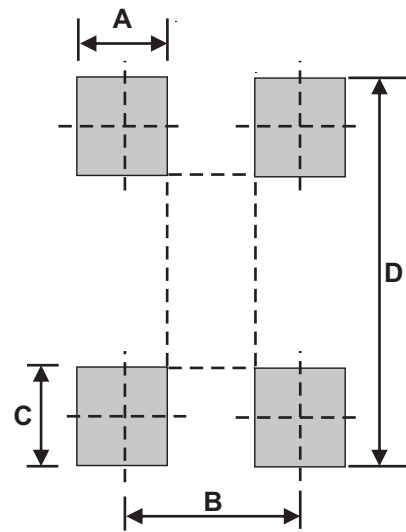

## Standard Package

Case Type	Reel	
	Qty per Reel	Reel Size
	(Pcs)	(inch)
TBS	1500	13