CHT-7404 DATASHEET

*Revision: 03.4
8-Jul-14
(Last Modified Date)*

High-Temperature, Hex Inverter

General Description

The CHT-7404 contains six independent inverter, performing the Boolean function :

$$Y = \bar{A}$$

This circuit is designed assuring latchup-free operation for all supply and temperature conditions.

The CHT-7404 can operate with supply voltages from 3.3 to 5V ($\pm 10\%$).

Features

- Qualified from -55 to +225°C (Tj)
- 3.3 to 5V ($\pm 10\%$) supply voltages
- Latchup-free at any supply and temperature condition
- Validated at 225°C for 30000 hours (CDIL14) and 20000 hours (CSOIC16) (and still on-going)
- Available in CDIL14 and CSOIC16 hermetic standard package

Applications

- Well logging,
 - Automotive, Aeronautics & Aerospace
 - Harsh Environments
-

Package and Pin Configuration

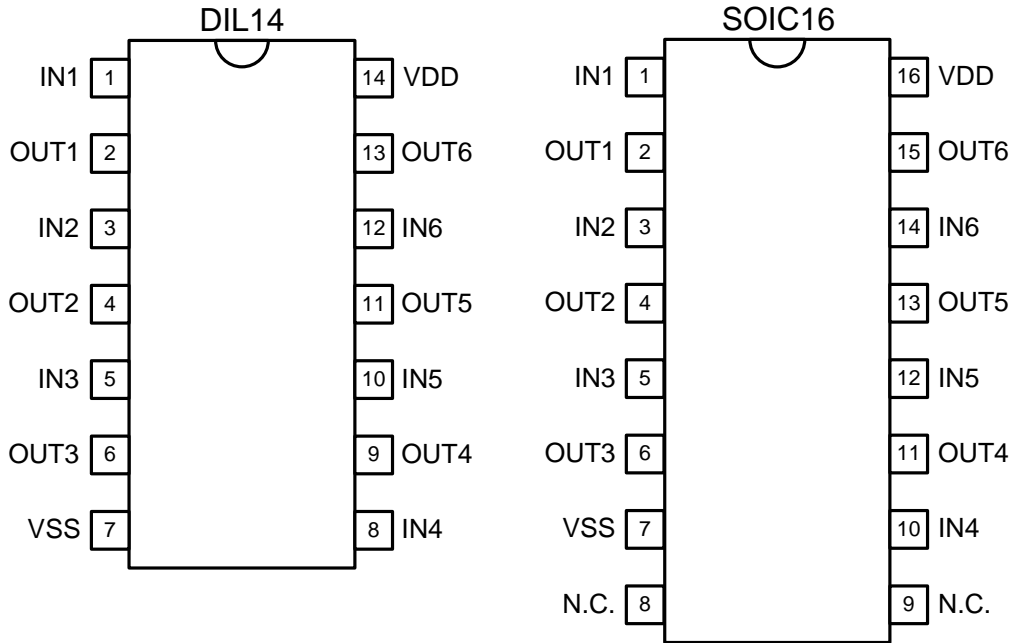

Function Table

INPUT	OUTPUT
A	Y
L	H
H	L

Function and Logical Diagrams

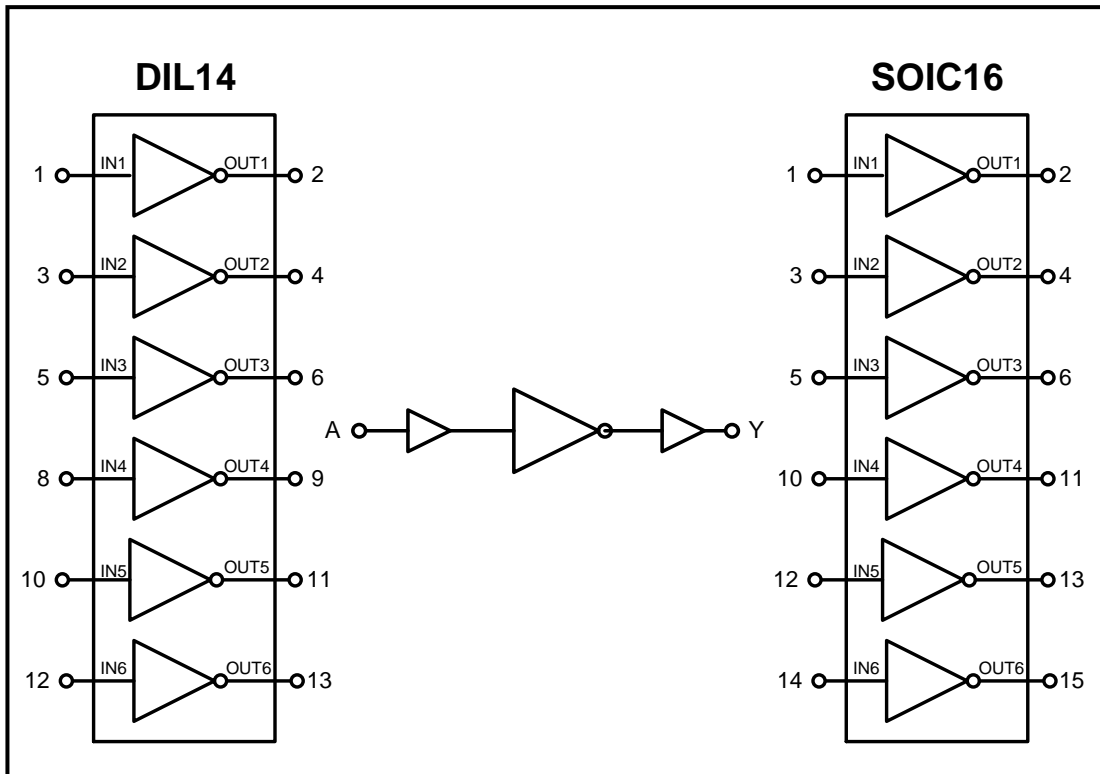

Figure 1. CHT-7404: simplified block diagram.

Absolute Maximum Ratings

 Supply Voltage V_{DD} to GND -0.5 to 6.0V
 Voltage on any Pin to GND -0.5 to $V_{DD}+0.5V$

ESD Rating (expected)

Human Body Model

1kV

Operating Conditions

 Supply Voltage V_{DD} to GND 3.3V to 5V ($\pm 10\%$)
 Junction temperature -55°C to +225°C

DC Electrical Characteristics

 Unless otherwise stated: $V_{DD}=5V$, $T_j=25^\circ C$. **Bold underlined** figures indicate values valid over the whole temperature range ($-55^\circ C < T_j < +225^\circ C$).

Parameter	Condition	Min	Typ	Max	Units
Supply voltage V_{DD}		2.97		5.5V	V
Quiescent current I_{DD}	$V_{DD} = 3.3V, T_j = -55^\circ C$			4	nA
	$V_{DD} = 5V, T_j = -55^\circ C$			13	
	$V_{DD} = 3.3V, T_j = 225^\circ C$			<u>2100</u>	
	$V_{DD} = 5V, T_j = 225^\circ C$			<u>2500</u>	
Minimum HIGH level output voltage V_{OH}	$V_{DD} = 3.3V, I_{OH} < 4mA$ (source)	<u>2.7</u>	3.04		V
	$V_{DD} = 5V, I_{OH} < 4mA$ (source)	<u>4.6</u>	4.82		
Maximum LOW level output voltage V_{OL}	$V_{DD} = 3.3V, I_{OL} < 4mA$ (sink)		0.28	<u>0.5</u>	V
	$V_{DD} = 5V, I_{OL} < 4mA$ (sink)		0.20	<u>0.4</u>	
Minimum HIGH level input voltage V_{IH}	$V_{DD} = 3.3V$	<u>2.4</u>	2.10		V
	$V_{DD} = 5V$	<u>3.7</u>	3.49		
Maximum LOW level input voltage V_{IL}	$V_{DD} = 3.3V$		1.72	<u>1.5</u>	V
	$V_{DD} = 5V$		2.16	<u>2.0</u>	
Input leakage current (source / sink) $\pm I_I$	$V_I = V_{CC}$ or GND, $V_{DD} = 3.3V$		± 1	<u>± 35</u>	nA
	$V_I = V_{CC}$ or GND, $V_{DD} = 5V$		± 2	<u>± 37</u>	

AC Electrical Characteristics

Unless otherwise stated: VDD=5V, T_i=25°C. **Bold underlined** figures indicate values valid over the whole temperature range (-55°C < T_i < +225°C).

Parameter	Condition	Temperature	Min	Typ	Max	Units
Propagation delay time from A to Y t _{PHL}	C _L =50pF	T _J =-55°C		9	16	ns
		T _J =25°C		10	18	
		T _J =225°C		14	25	
Propagation delay time from A to Y t _{PLH}	C _L =50pF	T _J =-55°C		11	20	ns
		T _J =25°C		12	21	
		T _J =225°C		13	23	
Output transition time High to Low t _{THL}	C _L =50pF	T _J =-55°C		13	17	ns
		T _J =25°C		14	18	
		T _J =225°C		17	<u>22</u>	
Output transition time Low to High t _{TLH}	C _L =50pF	T _J =-55°C		19	25	ns
		T _J =25°C		20	26	
		T _J =225°C		23	<u>30</u>	

AC Electrical Characteristics (cntd)

Unless otherwise stated: VDD=3.3V, $T_j=25^\circ\text{C}$. **Bold underlined** figures indicate values valid over the whole temperature range ($-55^\circ\text{C} < T_j < +225^\circ\text{C}$).

Parameter	Condition	Temperature	Min	Typ	Max	Units
Propagation delay time from A or B to Y t_{PHL}	$C_L=50\text{pF}$	$T_j=-55^\circ\text{C}$		16	28	ns
		$T_j=25^\circ\text{C}$		17	30	
		$T_j=225^\circ\text{C}$		23	40	
Propagation delay time from A or B to Y t_{PLH}	$C_L=50\text{pF}$	$T_j=-55^\circ\text{C}$		17	30	ns
		$T_j=25^\circ\text{C}$		18	32	
		$T_j=225^\circ\text{C}$		21	37	
Output transition time High to Low t_{THL}	$C_L=50\text{pF}$	$T_j=-55^\circ\text{C}$		20	26	ns
		$T_j=25^\circ\text{C}$		21	28	
		$T_j=225^\circ\text{C}$		27	<u>36</u>	
Output transition time Low to High t_{TLH}	$C_L=50\text{pF}$	$T_j=-55^\circ\text{C}$		23	30	ns
		$T_j=25^\circ\text{C}$		24	32	
		$T_j=225^\circ\text{C}$		26	<u>34</u>	

AC Waveforms

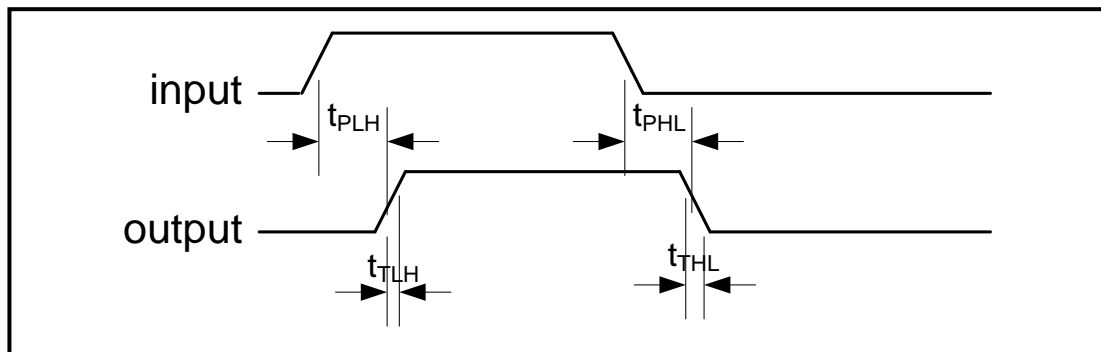
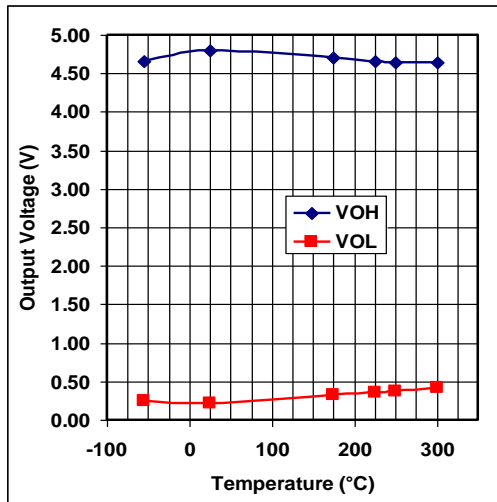
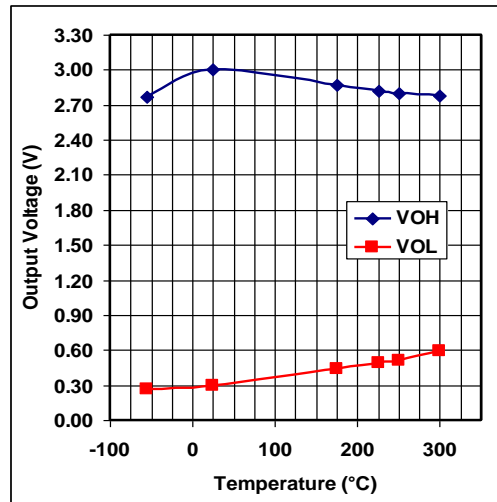

Figure 2. AC Waveforms

Typical Performance Characteristics



Output voltage levels versus temperature,
 $V_{DD} = 5V$



Output voltage levels versus temperature,
 $V_{DD} = 3.3V$

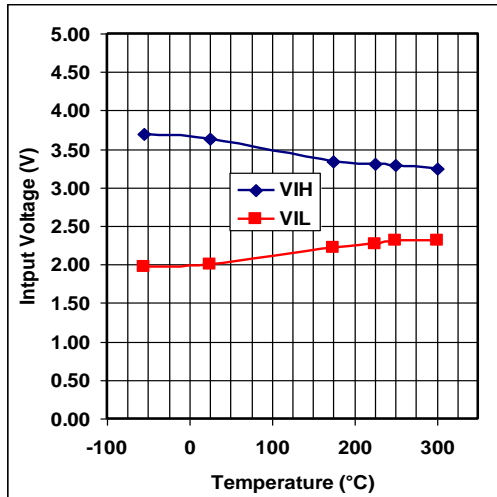

Input voltage levels versus temperature,
 $V_{DD} = 5V$

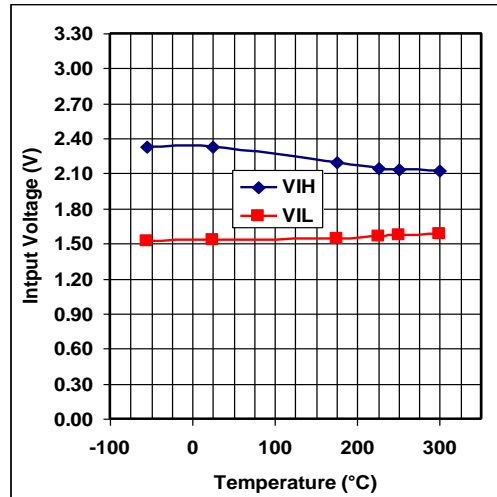

Input voltage levels versus temperature,
 $V_{DD} = 3.3V$

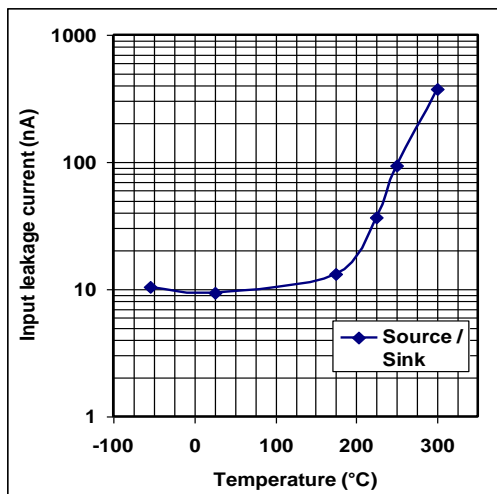

Input leakage current versus temperature,
 $V_{DD} = 5V$

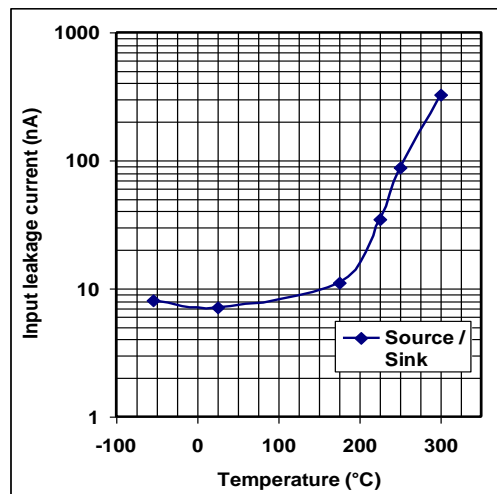

Input leakage current versus temperature,
 $V_{DD} = 3.3V$

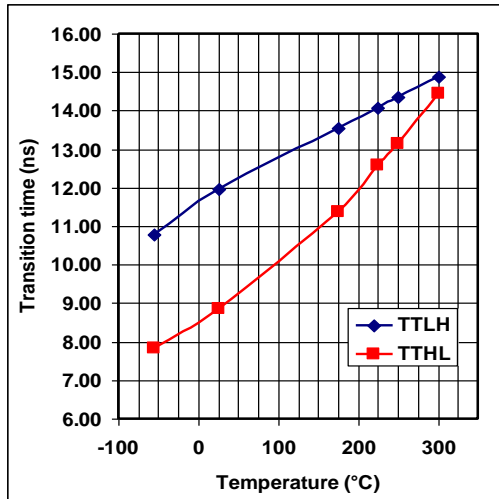

Transition times versus temperature,
V_{DD} = 5V

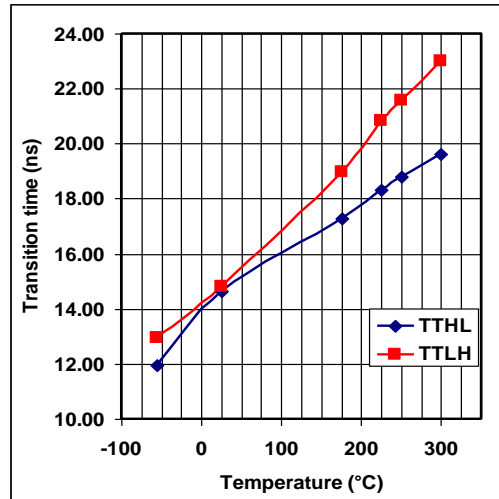

Transition times versus temperature,
V_{DD} = 3.3V

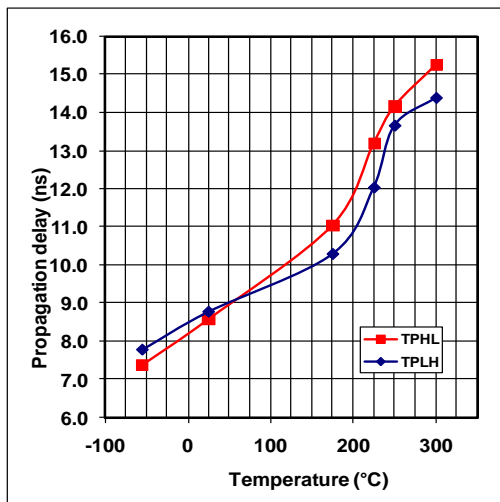

Propagation delays versus temperature,
V_{DD} = 5V

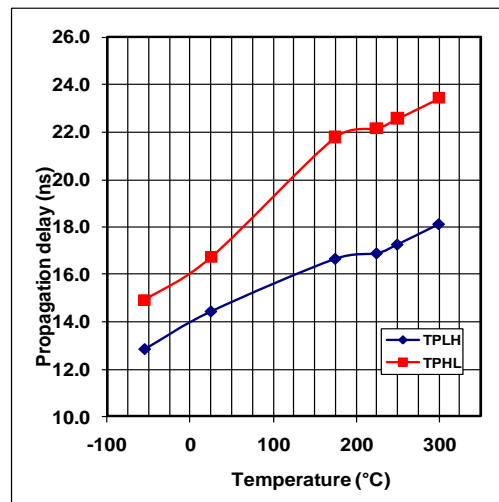

Propagation delays versus temperature,
V_{DD} = 3.3V

Ordering Information

Ordering Reference	Package	Temperature Range	Marking
CHT-7404-CDIL14-T	Ceramic DIL14	-55°C to +225°C	CHT-7404
CHT-7404-CSOIC16-T	Ceramic CSOIC16	-55°C to +225°C	CHT-7404

Package Dimensions

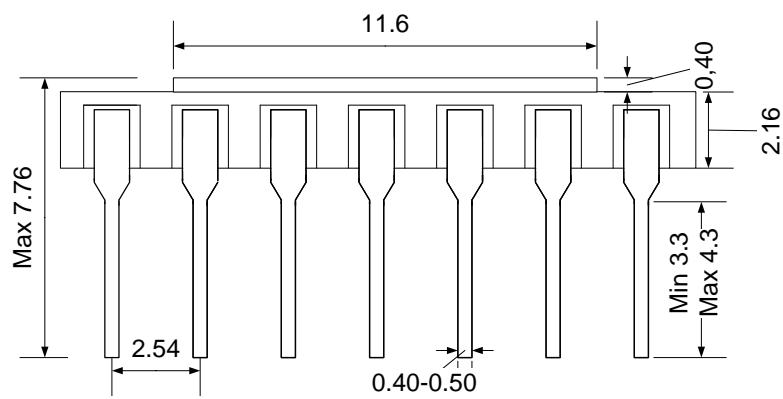
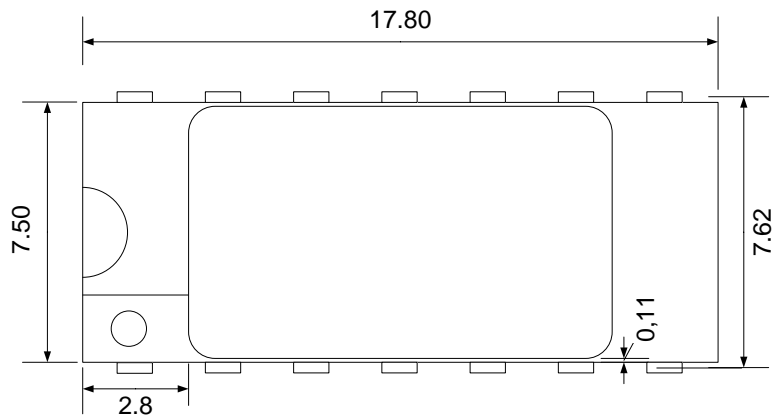

Drawing CDIL14 (mm +/- 10%)

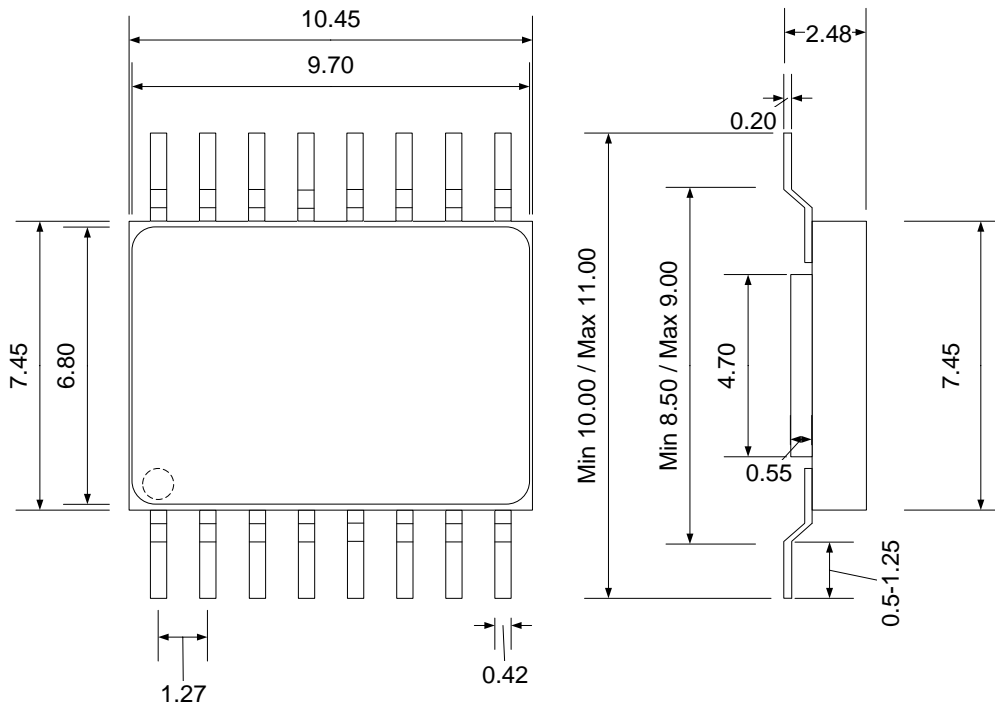

Drawing CSOIC16 (mm +/- 10%)

Contact & Ordering

CISSOID S.A.

Headquarters and contact EMEA:	CISSOID S.A. – Rue Francqui, 3 – 1435 Mont Saint Guibert - Belgium T : +32 10 48 92 10 - F: +32 10 88 98 75 Email: sales@cissoid.com
Representatives	Visit our website: www.cissoid.com

Disclaimer

Neither CISSOID, nor any of its directors, employees or affiliates make any representations or extend any warranties of any kind, either express or implied, including but not limited to warranties of merchantability, fitness for a particular purpose, and the absence of latent or other defects, whether or not discoverable. In no event shall CISSOID, its directors, employees and affiliates be liable for direct, indirect, special, incidental or consequential damages of any kind arising out of the use of its circuits and their documentation, even if they have been advised of the possibility of such a damage. The circuits are provided "as is". CISSOID has no obligation to provide maintenance, support, updates, or modifications.