

## Outline: 产品概要

- Magnetic shielded structure: excellent resistance to electro magnetic interference(EMI).  
磁屏蔽结构：抗电磁干扰(EMI)性能强。
- A composite structure, ultra low buzz noise.  
一体成型结构，超低蜂鸣噪音。
- Low loss, high efficiency, wide application frequency.  
低损耗，高效率，应用频率宽。
- Lightweight design, save space, suitable for high density SMT.  
轻薄型设计，节省空间，适合高密度贴装。
- Die-casting by low loss alloy powder: low impedance, small parasitic capacitance.  
低损耗合金粉末压铸：低阻抗，寄生电容小。
- Operating temperature :  $-40^{\circ}\text{C} \sim +125^{\circ}\text{C}$  (Including coil's temperature rise)  
工作温度： $-40^{\circ}\text{C} \sim +125^{\circ}\text{C}$  (包含线圈发热)

## 1 Appearance and dimensions (mm) 外形尺寸

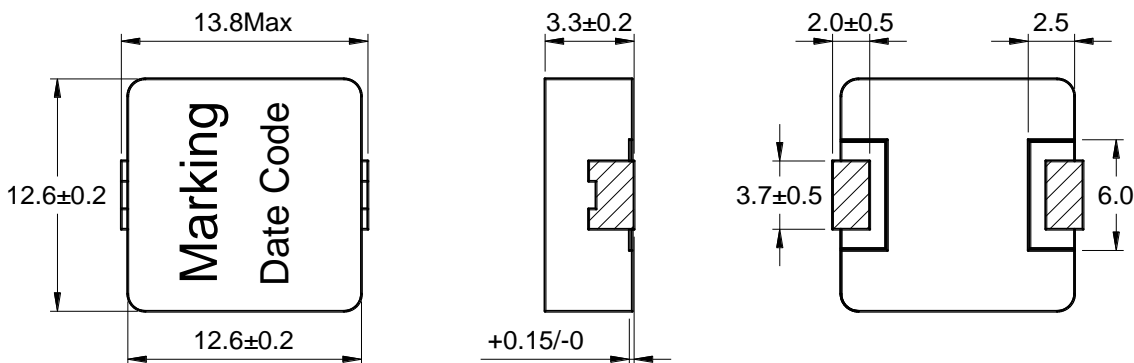

## 2 Marking 印字标识



## 3 Reference land pattern (mm) 参考基板尺寸

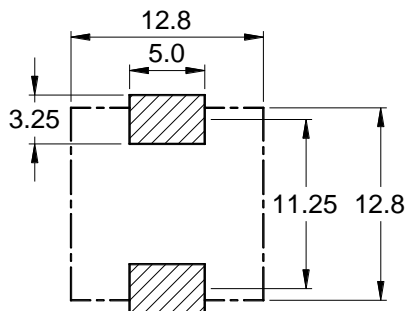

## 4 Schematic 原理图

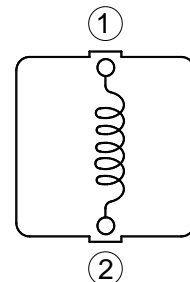

**5 Electrical characteristics**

**电气特性**

Part No. 型号	Inductance (μH) 电感值 ※1 ±20%	D.C.R. (mΩ) 直流电阻		Saturation current (A) 饱和电流 ※2 Typical	Temperature rise current (A) 温升电流 ※3 Typical
		Typical	Max		
CSAB1235A-R47M	0.47	1.60	1.90	58.0	30.0
CSAB1235A-R68M	0.68	1.70	2.30	40.0	29.0
CSAB1235A-1R0M	1.00	2.30	2.60	35.0	25.0
CSAB1235A-1R5M	1.50	5.30	6.50	25.0	16.5
CSAB1235A-2R2M	2.20	6.90	8.50	24.0	14.5
CSAB1235A-3R3M	3.30	9.50	13.0	18.0	12.0
CSAB1235A-4R7M	4.70	17.1	19.5	16.0	9.00

■ All data is tested based on 25°C ambient temperature.

所有数据基于环境温度 25°C条件下测试。

※1 Inductance measure condition at 100kHz, 1V.

电感测试条件为 100kHz, 1V。

※2 Saturation current: the actual value of DC current when the inductance decrease 30% of its initial value.

饱和电流: 电感值下降其初始值的 30%时所加载的实际直流电流值。

※3 Temperature rise current: the actual value of DC current when the temperature rise is ΔT40°C(Ta=25°C).

温升电流: 使产品温度上升到 ΔT40°C时所加载的实际直流电流值(Ta=25°C)。

※ Special remind: Circuit design, component placement, PWB size and thickness, cooling system and etc. all will affect the product temperature. Please verify the product temperature in the final application.

特别提醒: 线路设计, 组件布局, 印刷线路板(PWB)尺寸及厚度, 散热系统等均会影响产品温度。

请务必在最终应用时, 验证产品发热状况。

**6 Saturation current VS temperature rise current curve  
饱和电流 VS 温升电流曲线**

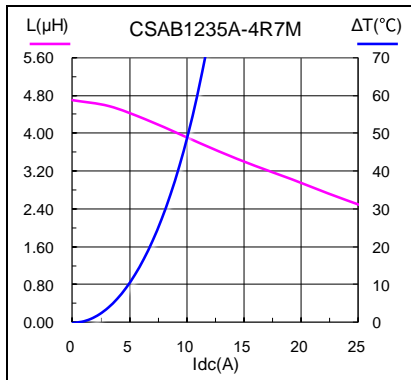
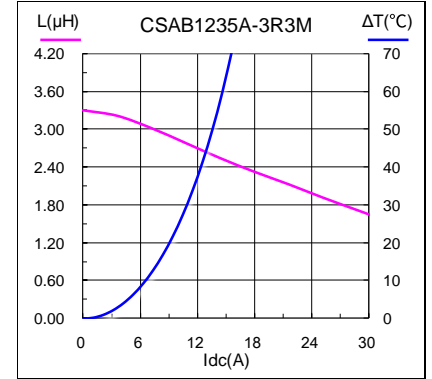
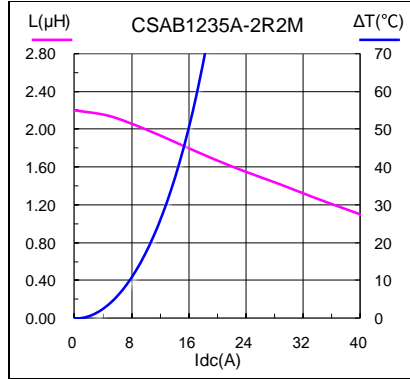
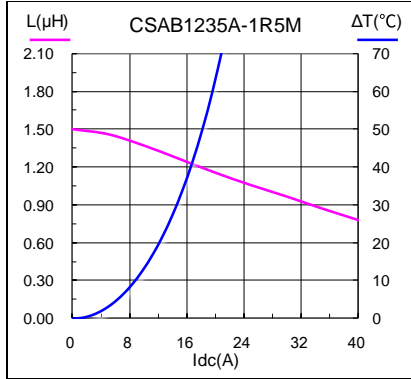
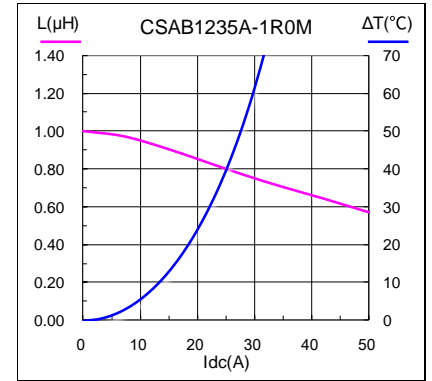
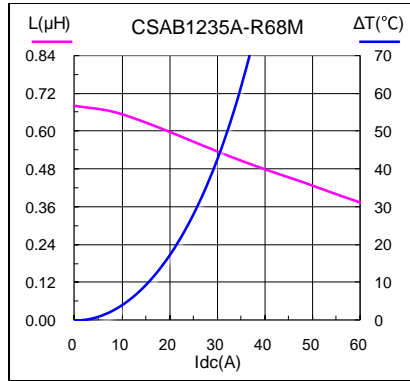
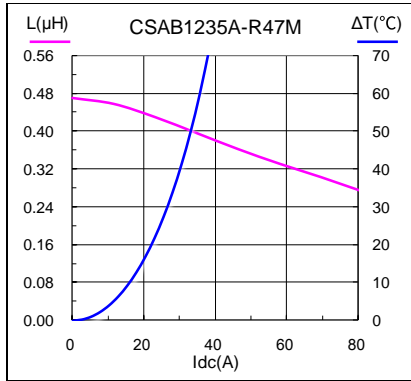

## 7 Packing specification

### 包装规格

#### 7.1 Carrier tape dimensions (mm)

##### 载带尺寸

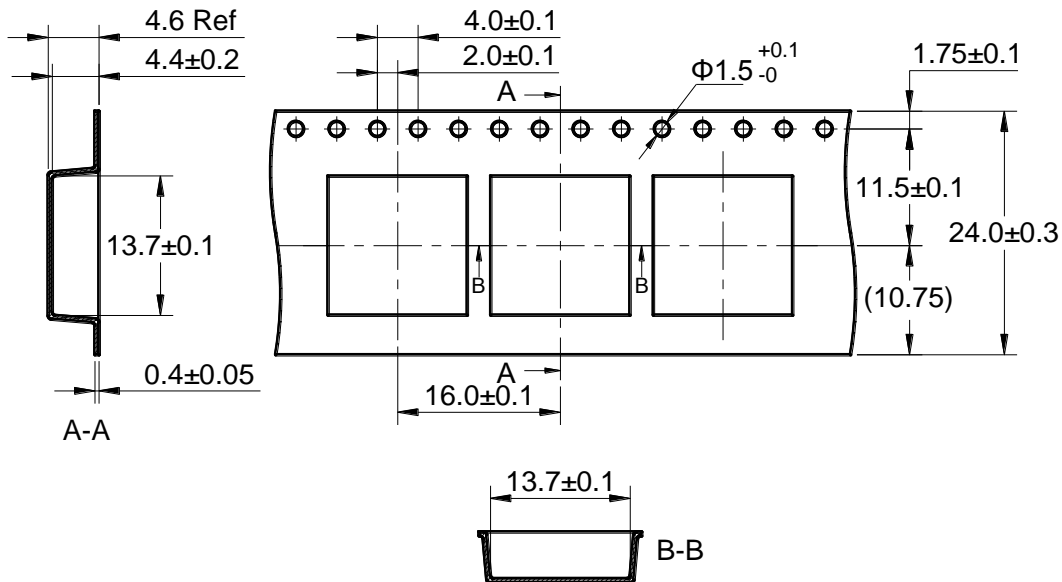

※ Packing is referred to the international standard IEC 60286-3.  
包装参照国际标准 IEC 60286-3。

#### 7.2 Tape direction

##### 捆包方向

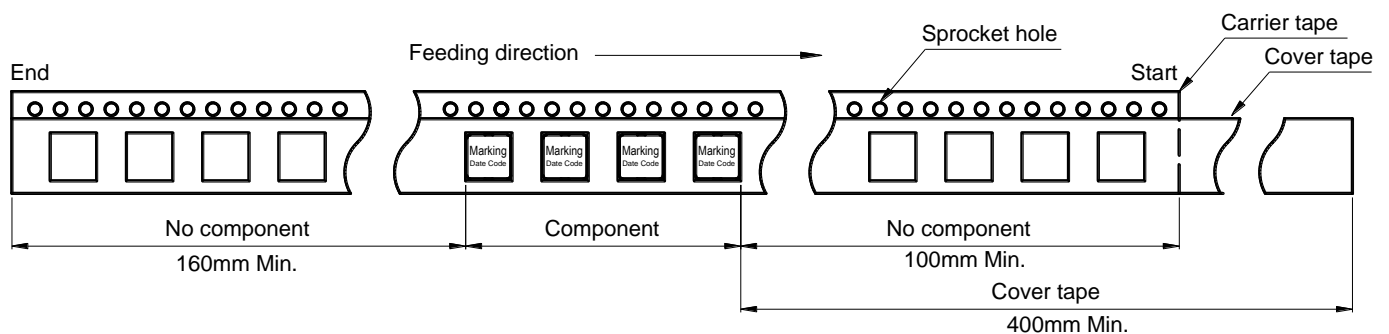

#### 7.3 Cover tape peel off condition

##### 盖带剥离条件

- Cover tape peel force shall be 0.1 to 1.3N.  
盖带剥离力度为 0.1~1.3N。
- Reference peel speed 300±10mm/min.  
参考剥离速度 300±10mm/分钟。

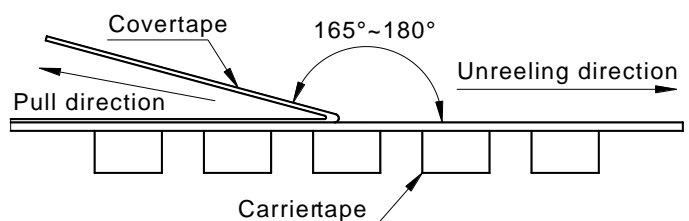

## 7.4 Reel dimensions (mm)

卷盘尺寸

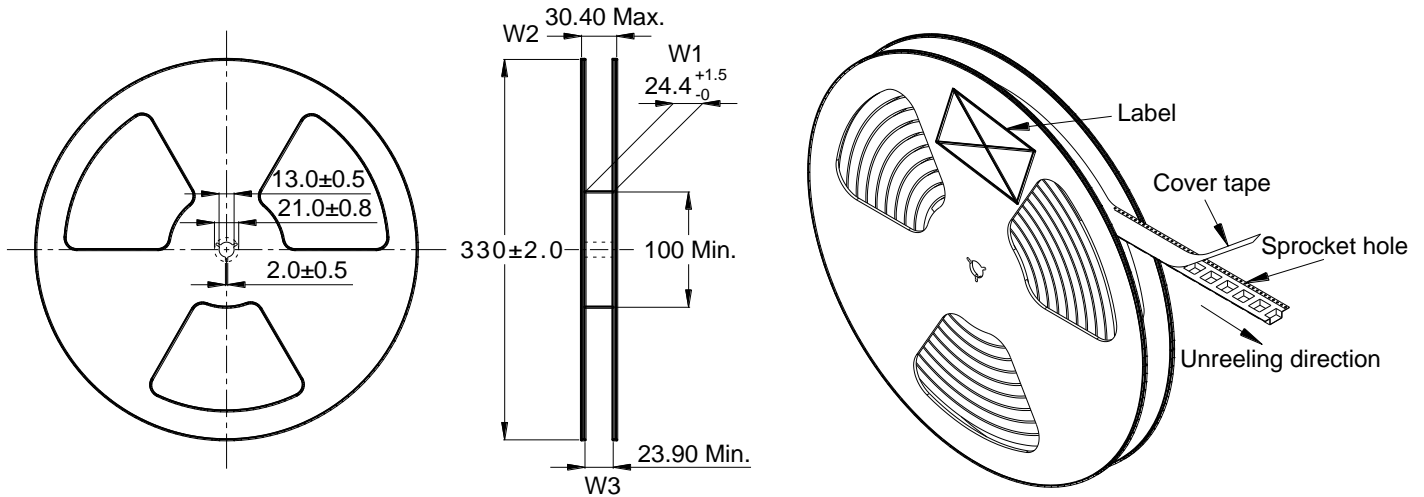

## 7.5 Carton dimensions and packing quantity

包装箱尺寸和包装数量

■ Inner Carton: 340×340×95mm  
内包装盒

■ Out Carton : 355×355×385mm  
外包装箱

Product Series 产品系列	Quantity / Reel 数量 / 卷	Inner Carton Quantity 内盒 包装数量	Out Carton Quantity 外箱 包装总数量
CSAB1235A	500pcs	(500×2) = 1000pcs	(1000×3) = 3000pcs

## 7.6 Label making

标签标识

The following items will be marked on the reel of product label and shipping label.  
以下项目将明确标识于产品卷盘标签以及运输标签上。

Production Label 产品标签
■ Part No. 产品型号
■ Electrical Information 产品电性信息
■ Quantity 数量
■ Packing No. 包装流水号

Shipping Label 运输标签
■ Customer Name 客户名称
■ Customer Part No. 客户型号
■ Supplier Part No. 供应商型号
■ Supplier Name 供应商名称
■ Country of origin 产品产地

## 8 Soldering specification

### 焊接规格

#### 8.1 Reflow profile for SMT components

SMT 回流焊温度曲线

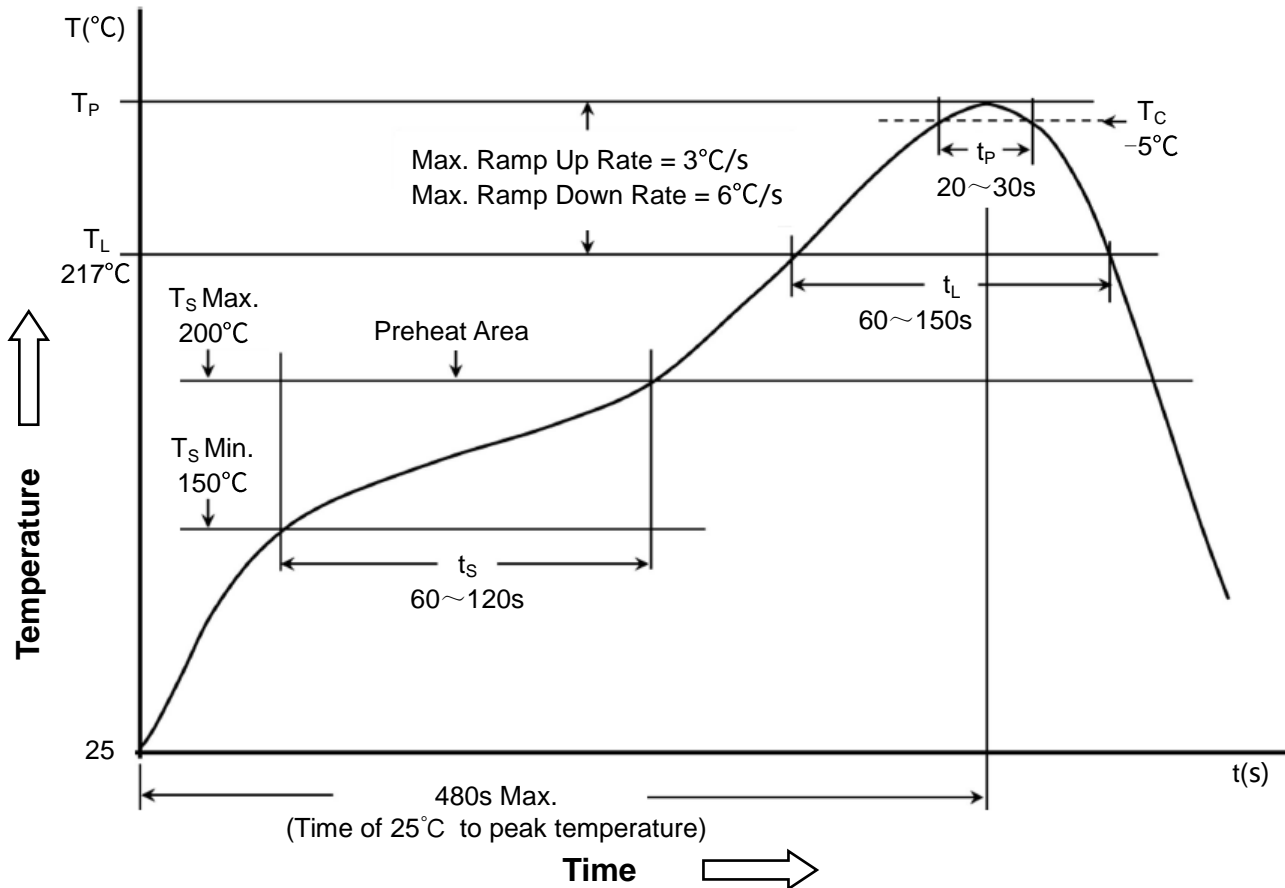

#### 8.2 Classification of peak package body temperature (T<sub>P</sub>)

封装体峰值温度(T<sub>P</sub>)分类

	Package Thickness 封装厚度	Package Volume 封装体积		
		<350 mm <sup>3</sup>	350~2000 mm <sup>3</sup>	>2000 mm <sup>3</sup>
PB-Free Assembly 无铅装配	<1.6mm	260°C	260°C	260°C
	1.6~2.5mm	260°C	250°C	245°C
	≥2.5mm	250°C	245°C	245°C

※ Reflow is referred to standard IPC/JEDEC J-STD-020D.  
回流焊参照标准 IPC/JEDEC J-STD-020D。