

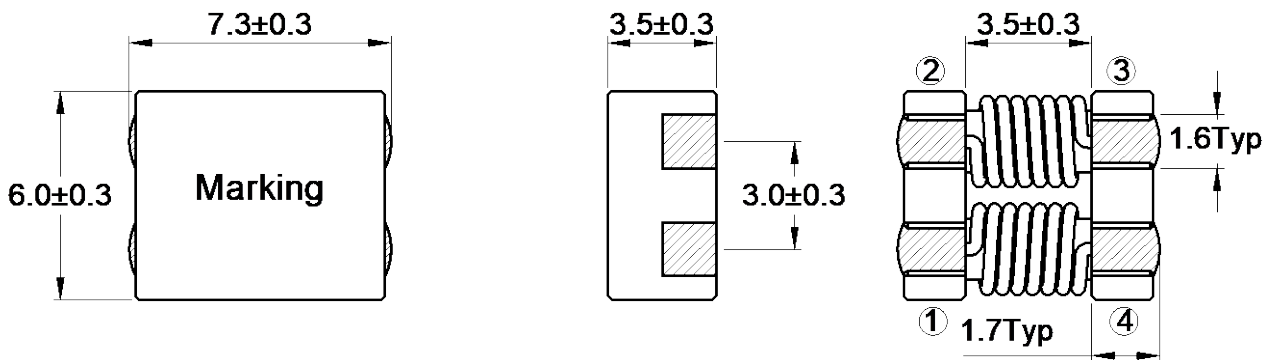

Outline: 产品概要

- Excellent impedance characteristics, making it great for suppressing common mode noise.
高阻抗特性，能高效抑制共模噪音效果。
- Low profile design makes it optimal for surface mounting.
因低的高度设计，适合表面安装。
- Measures against common mode noise in power lines for various DC power lines, multimedia devices, and various electronic devices, including automotive power trains.
各种电子产品、多媒体设备，包括车载动力传递的 DC 电源线的共模噪音抑制。
- Operating temperature : $-40^{\circ}\text{C} \sim +125^{\circ}\text{C}$
(Including coil's temperature rise)
工作温度: $-40^{\circ}\text{C} \sim +125^{\circ}\text{C}$ (包含线圈发热)

1 Appearance and Dimensions (mm) 外形尺寸 (mm)



2 Marking 印字标识



3 Reference Land Pattern (mm) 参考基板尺寸 (mm)

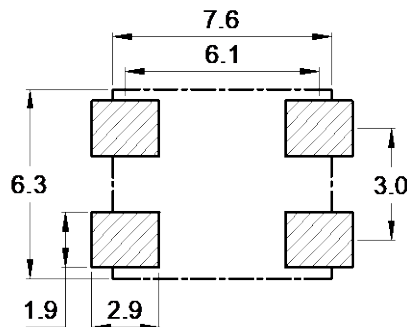

4 Schematic 原理图

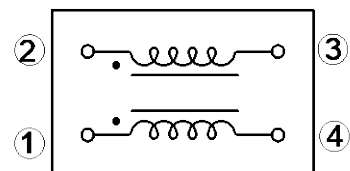

5 Electrical Characteristics

电气特性

Part No. 型号	Inductance (μ H) 电感值※1	Impedance (Ω) 共模阻抗※2		D.C.R. (m Ω) 直流电阻		Rated Current (A) 额定电流※3	Rated Voltage (V) 额定电压	Insulation Resistance (M Ω) 绝缘耐压
	$\pm 50\%$	Min	Typical	Typical	Max	Max	Max	Min
CSTS0740-141	0.80	100	140	4.10	5.00	9.00	80.0	10.0
CSTS0740-301	2.20	230	300	6.60	8.00	5.20	80.0	10.0
CSTS0740-501	3.00	300	500	8.80	10.0	5.00	80.0	10.0
CSTS0740-701	3.50	500	700	9.00	11.0	4.30	80.0	10.0
CSTS0740-102	5.00	800	1,000	12.0	14.5	3.60	80.0	10.0
CSTS0740-132	7.20	910	1,300	15.5	21.0	2.50	80.0	10.0
CSTS0740-272	13.5	2,000	2,700	43.5	55.0	1.00	80.0	10.0
CSTS0740-302	18.5	2,500	3,000	63.0	75.0	0.90	80.0	10.0

■ All data is tested based on 25°C ambient temperature.

所有数据基于环境温度 25°C 条件下测试。

※1 Inductance measure condition at 100KHz,0.1V.

电感测试条件为 100KHz,0.1V。

※2 Impedance measure condition at 100MHz,0.5V.

共模阻抗测试条件为 100MHz,0.5V。

※3 Rated current: the value of DC current when the temperature rise is $\Delta T 40^{\circ}\text{C}$ ($T_a=25^{\circ}\text{C}$).

额定电流: 使产品温度上升到 $\Delta T 40^{\circ}\text{C}$ 时所加载的直流电流值 ($T_a=25^{\circ}\text{C}$)。

※ Special remind: Circuit design, component placement, PCB size and thickness, cooling system and etc. all will affect the product temperature. Please verify the product temperature in the final application.

特别提醒: 线路设计, 组件布局, 印刷线路板(PCB)尺寸及厚度, 散热系统等均会影响产品温度。

请务必在最终应用时, 验证产品发热状况。

**6 Impedance vs Frequency Curve
阻抗值 VS 频率曲线**

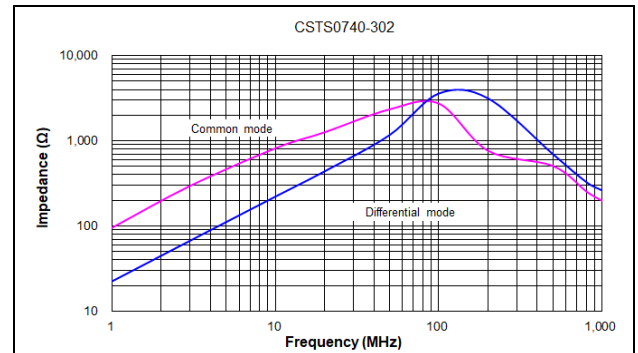
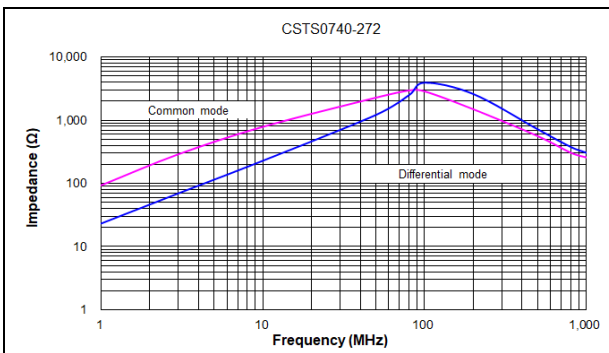
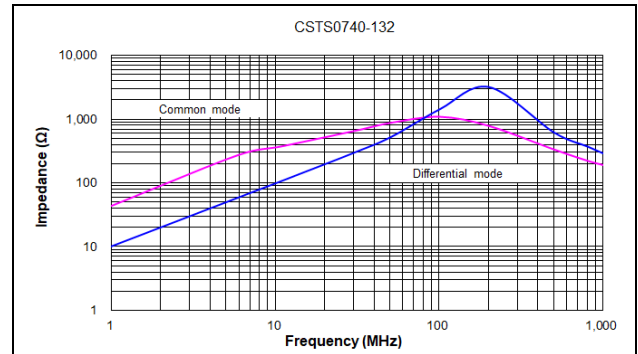
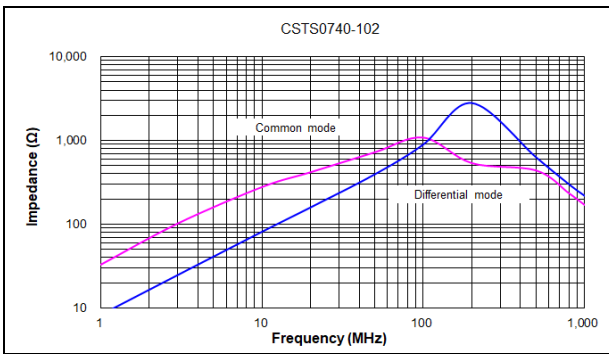
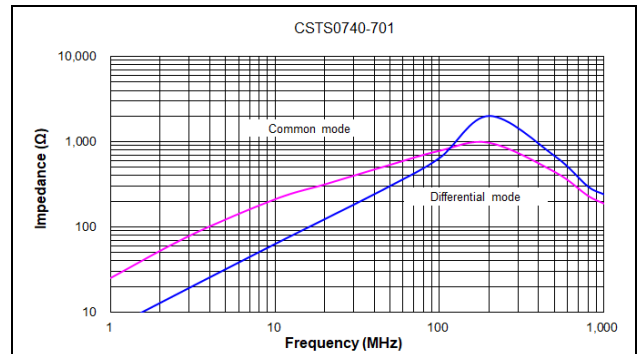
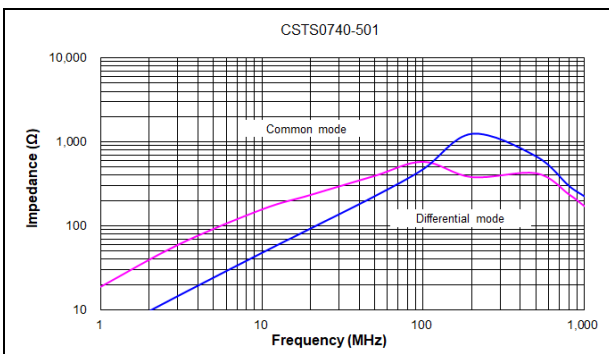
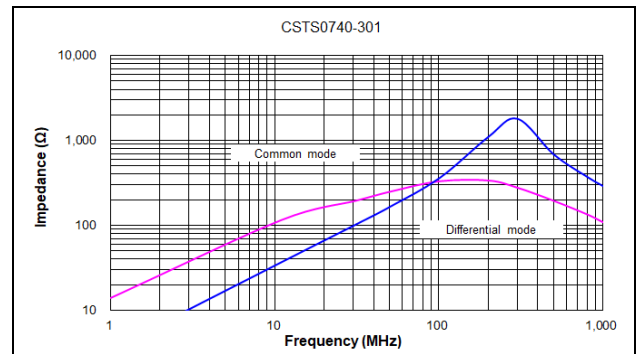
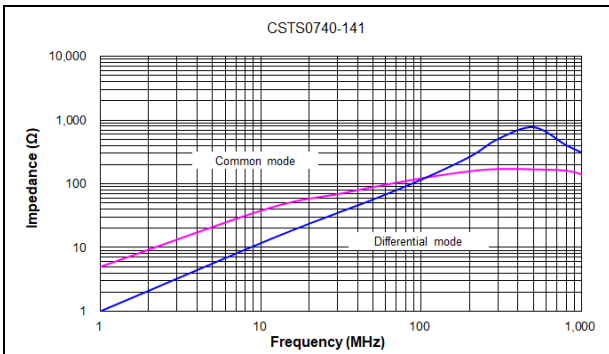

7 Packing Specification

包装规格

7.1 Carrier Tape Dimensions (mm)

载带尺寸

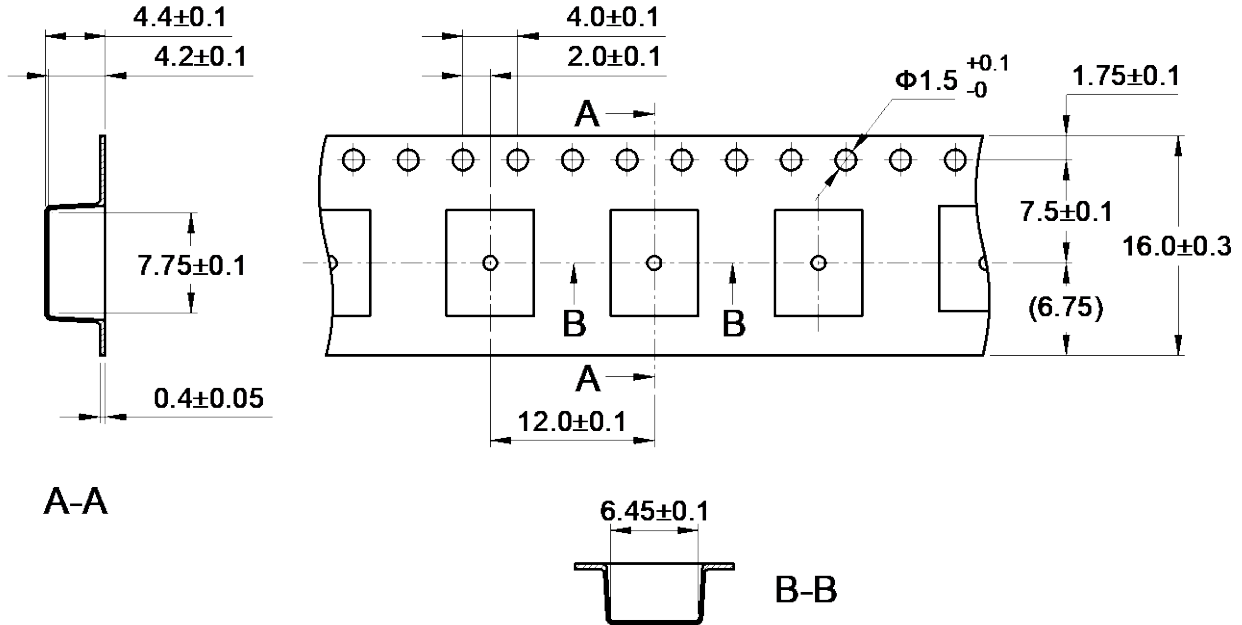

※ Packing is referred to the international standard IEC 60286-3.
包装参照国际标准 IEC 60286-3。

7.2 Tape Direction

捆包方向

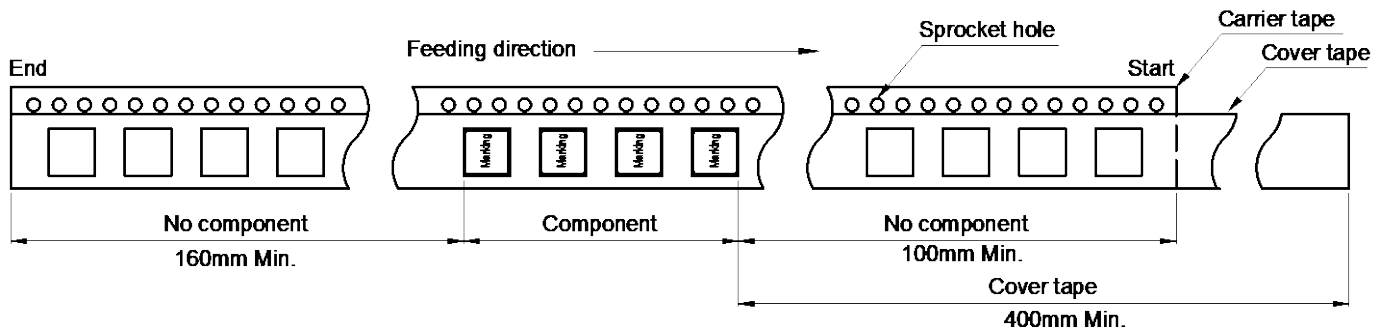

7.3 Cover Tape Peel Off Condition

盖带剥离条件

- Cover tape peel force shall be 0.1 to 1.3N.
盖带剥离力度为 0.1~1.3N。
- Reference peel speed 300±10mm/min.
参考剥离速度 300±10mm/分钟。

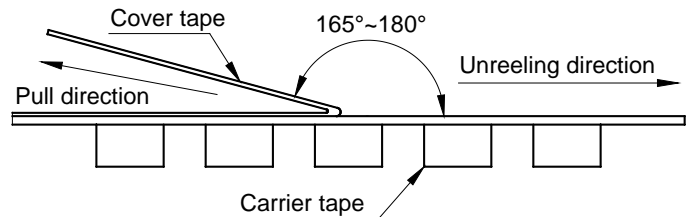

7.4 Reel Dimensions (mm) 卷盘尺寸(mm)

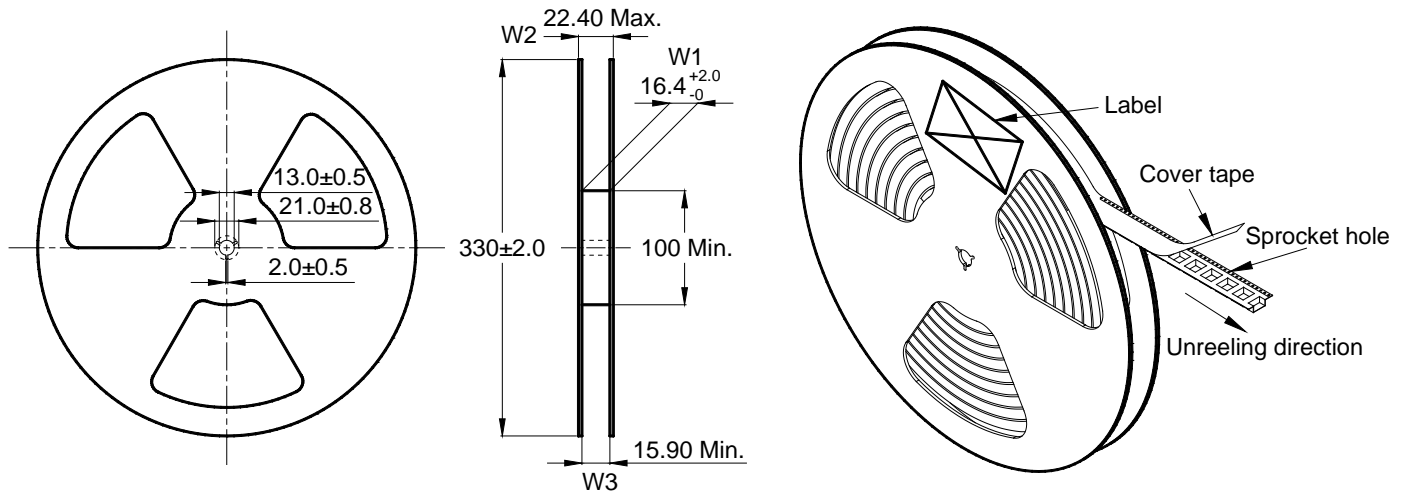

7.5 Carton Dimensions and Packing Quantity 包装箱尺寸和包装数量

■ Inner Carton: 340×340×95mm
内包装盒

■ Out Carton : 355×355×385mm
外包装箱

Product Series 产品系列	Quantity / Reel 数量 / 卷	Inner Carton Quantity 内盒 包装数量	Out Carton Quantity 外箱 包装总数量
CSTS0740	1000pcs	(1000×3) = 3000pcs	(3000×3) = 9000pcs

7.6 Label Making 标签标识

The following items will be marked on the tray of product label and shipping label.
以下项目将明确标识于产品吸塑盘标签以及运输标签上。

Production Label 产品标签
■ Packing No. 包装流水号
■ Quantity 数量
■ Shipment Date 出货日期
■ Part No. 产品型号
■ Customer Part No. 客户型号
■ Customer Po No. 客户订单号

Shipping Label 运输标签
■ Packing No. 包装流水号
■ Quantity 数量
■ Shipment Date 出货日期
■ Part No. 产品型号
■ Customer Part No. 客户型号
■ Customer Po No. 客户订单号

8 Soldering Specification

焊接规格

8.1 Reflow Profile for SMT Components

SMT 回流焊温度曲线

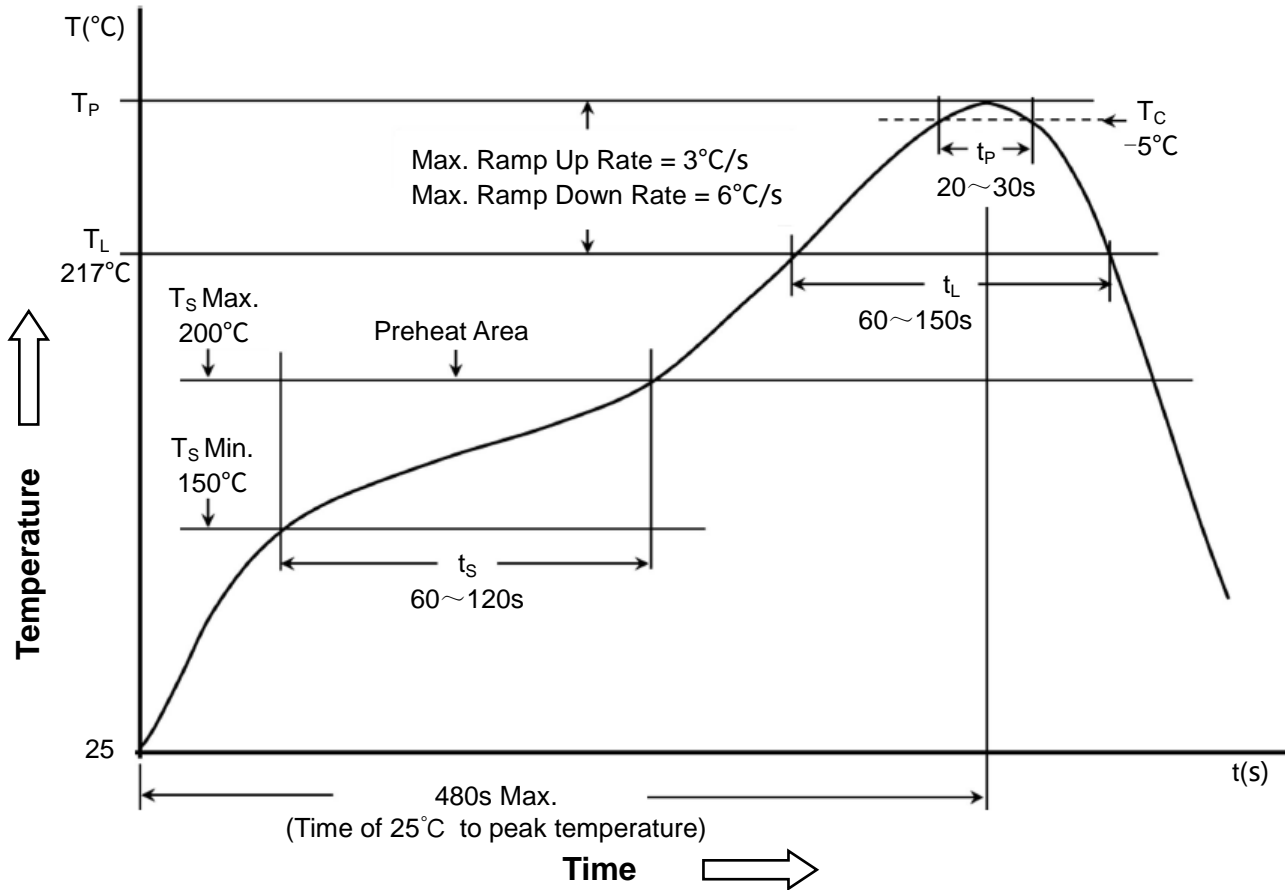

8.2 Classification of Peak Package Body Temperature (T_P)

封装体峰值温度(T_P)分类

	Package Thickness 封装厚度	Package Volume 封装体积		
		<350 mm ³	350~2000 mm ³	>2000 mm ³
PB-Free Assembly 无铅装配	<1.6mm	260°C	260°C	260°C
	1.6~2.5mm	260°C	250°C	245°C
	≥2.5mm	250°C	245°C	245°C

※ Reflow is referred to standard IPC/JEDEC J-STD-020D.

回流焊参照标准 IPC/JEDEC J-STD-020D.