

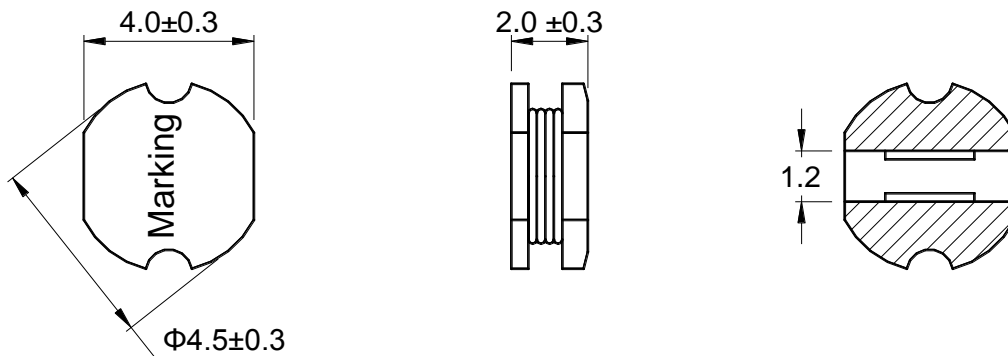

Outline: 产品概要

- Small size, high rated current, low DCR.
小尺寸，耐大电流，低直流电阻。
- Lead free product, RoHS compliant.
无铅产品，符合 RoHS 指令。
- Carrier tape packing, suitable for SMT process.
载带包装，适用于回流焊 SMT 工艺。
- Widely used in buck converter, displayer, laptop, network communication equipment, and etc.
广泛应用于升降压转换器，显示器，笔记本电脑，网络通信设备等。
- Operating temperature : $-40^{\circ}\text{C} \sim +125^{\circ}\text{C}$
(Including coil's temperature rise)
工作温度： $-40^{\circ}\text{C} \sim +125^{\circ}\text{C}$ (包含线圈发热)

1 Appearance and dimensions (mm) 外形尺寸



2 Marking 印字标识



3 Reference land pattern (mm) 参考基板尺寸

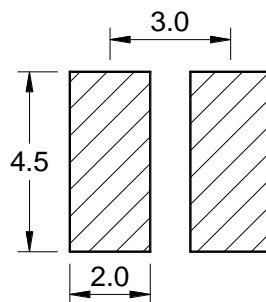

4 Schematic 原理图

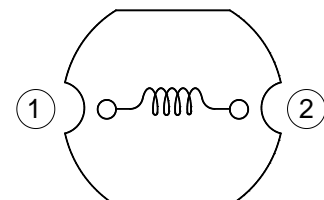

5 Electrical characteristics

电气特性

Part No. 型号	Inductance (μH) 电感值 ※1	D.C.R. (mΩ) 直流电阻		Saturation current (A) 饱和电流 ※2		Temperature rise current (A) 温升电流 ※3
		Typical	Max	Typical	Max	Typical
SP42-1R2M	1.20 ±20%	16.3	19.6	4.30	3.44	4.78
SP42-2R5M	2.50 ±20%	40.0	48.0	3.00	2.40	3.01
SP42-3R3M	3.30 ±20%	53.3	64.0	2.30	1.84	2.50
SP42-4R7M	4.70 ±20%	70.1	84.1	2.10	1.68	2.30
SP42-5R6M	5.60 ±20%	81.0	97.2	1.82	1.46	2.14
SP42-6R8M	6.80 ±20%	95.0	114	1.78	1.42	1.98
SP42-8R2M	8.20 ±20%	112	134	1.62	1.30	1.82
SP42-100K	10.0 ±10%	138	166	1.38	1.10	1.64
SP42-120K	12.0 ±10%	160	192	1.22	0.98	1.52
SP42-150K	15.0 ±10%	210	252	1.19	0.95	1.33
SP42-180K	18.0 ±10%	257	308	1.15	0.92	1.20
SP42-220K	22.0 ±10%	290	348	1.00	0.80	1.13
SP42-270K	27.0 ±10%	395	474	0.85	0.68	0.94
SP42-330K	33.0 ±10%	465	558	0.78	0.62	0.86
SP42-390K	39.0 ±10%	515	618	0.75	0.60	0.82
SP42-470K	47.0 ±10%	680	816	0.63	0.50	0.71
SP42-560K	56.0 ±10%	760	912	0.60	0.48	0.68
SP42-680K	68.0 ±10%	956	1,147	0.55	0.44	0.60
SP42-820K	82.0 ±10%	1,100	1,320	0.48	0.38	0.56
SP42-101K	100 ±10%	1,400	1,680	0.46	0.37	0.46
SP42-121K	120 ±10%	1,540	1,848	0.44	0.35	0.44
SP42-151K	150 ±10%	2,120	2,544	0.36	0.29	0.36

■ All data is tested based on 25°C ambient temperature.

所有数据基于环境温度 25°C 条件下测试。

※1 Inductance measure condition at 1kHz, 0.25V.

电感测试条件为 1kHz, 0.25V。

※2 Saturation current: the actual value of DC current when the inductance decrease 20% of its initial value.

饱和电流: 电感值下降其初始值的 20% 时所加载的实际直流电流值。

※3 Temperature rise current: the actual value of DC current when the temperature rise is ΔT40°C (Ta=25°C).

温升电流: 使产品温度上升到 ΔT40°C 时所加载的实际直流电流值 (Ta=25°C)。

※ Special remind: Circuit design, component placement, PWB size and thickness, cooling system and etc.

all will affect the product temperature. Please verify the product temperature in the final application.

特别提醒: 线路设计, 组件布局, 印刷线路板(PWB)尺寸及厚度, 散热系统等均会影响产品温度。

请务必在最终应用时, 验证产品发热状况。

6 Saturation current VS temperature rise current curve 饱和电流 VS 温升电流曲线

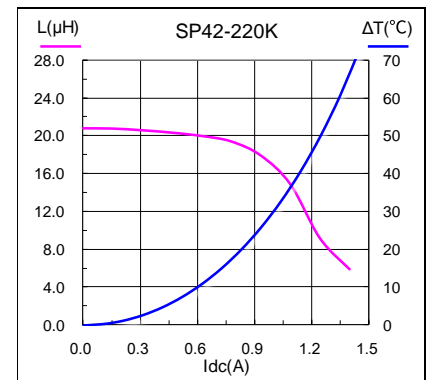
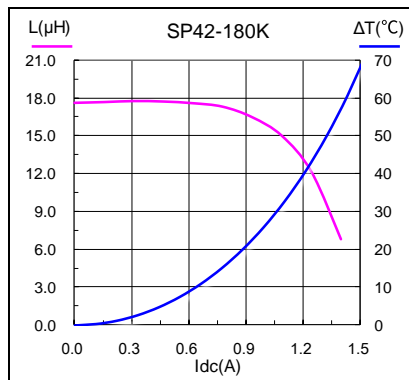
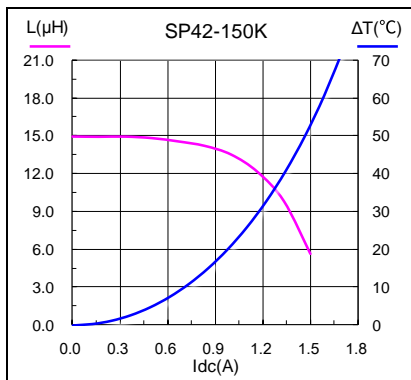
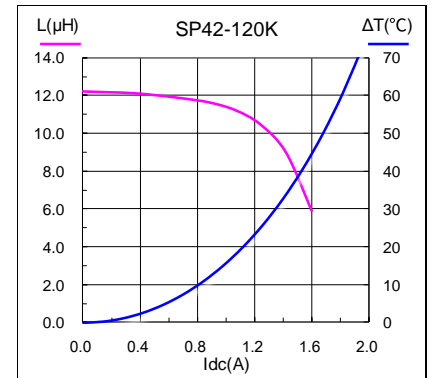
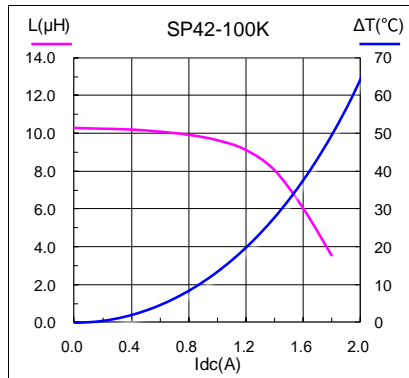
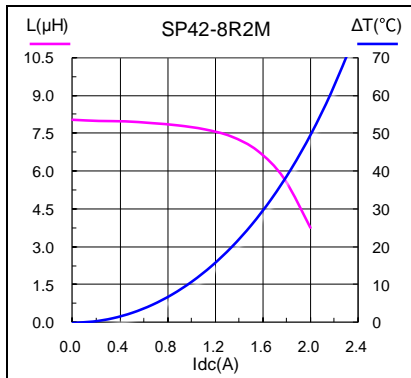
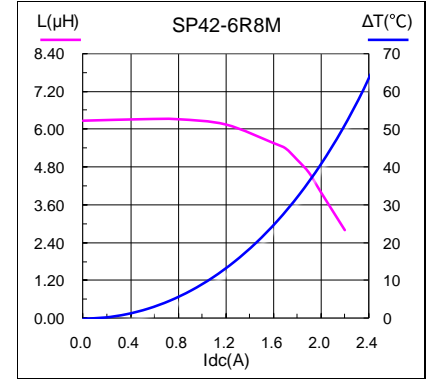
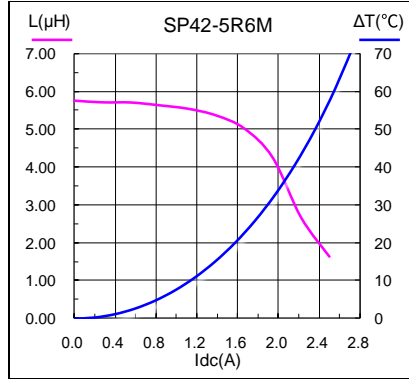
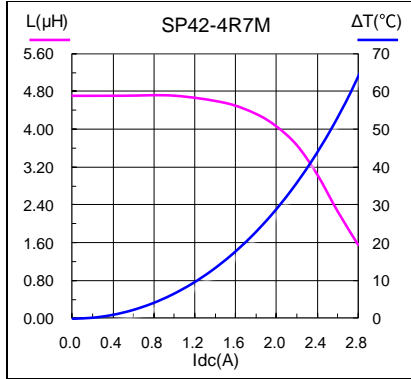
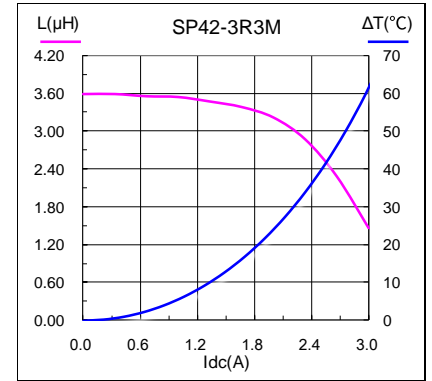
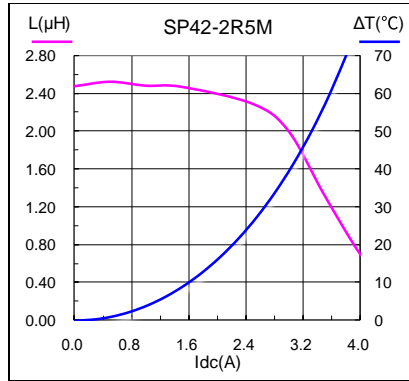
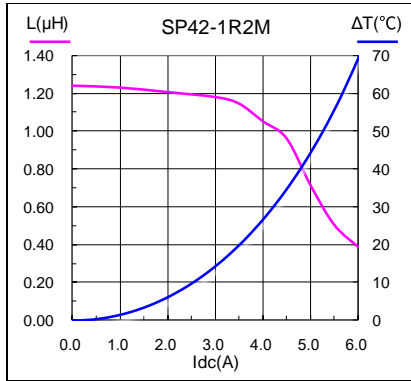

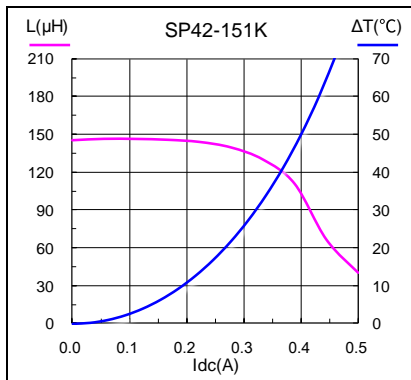
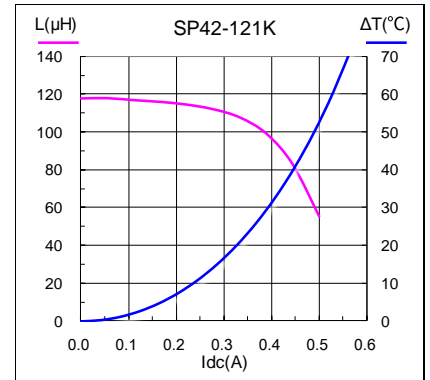
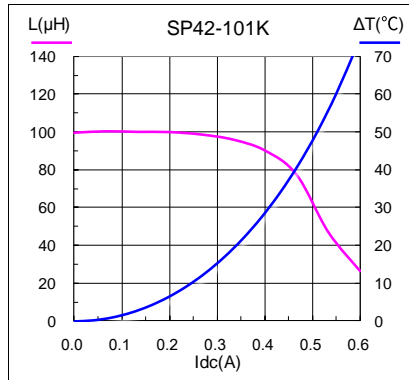
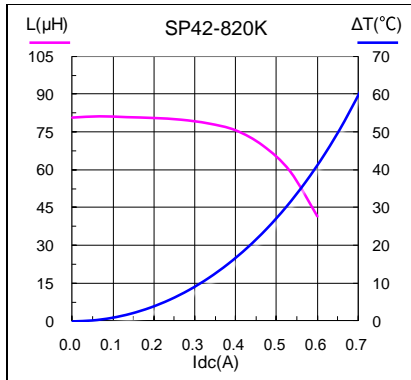
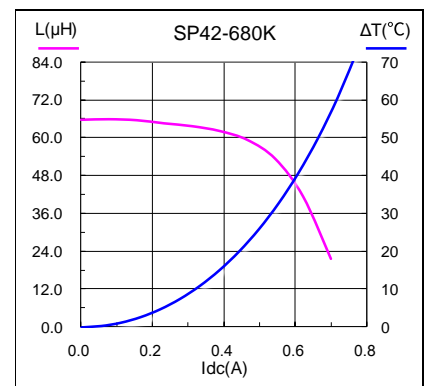
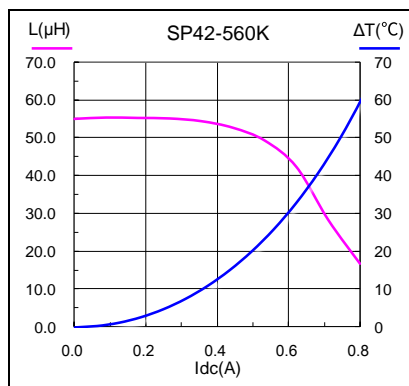
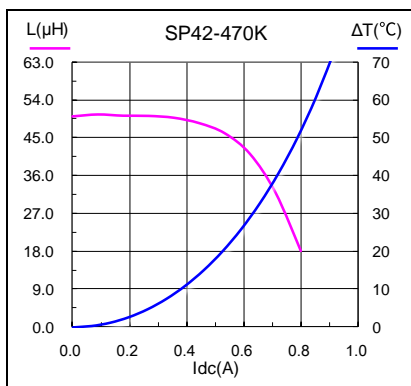
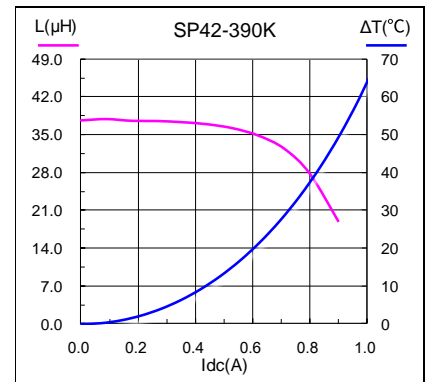
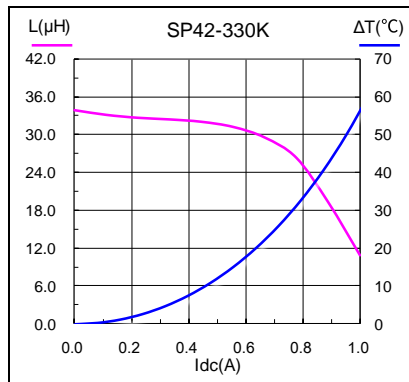
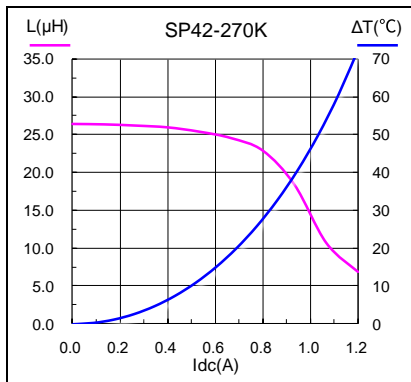

7 Packing specification

包装规格

7.1 Carrier tape dimensions (mm)

载带尺寸

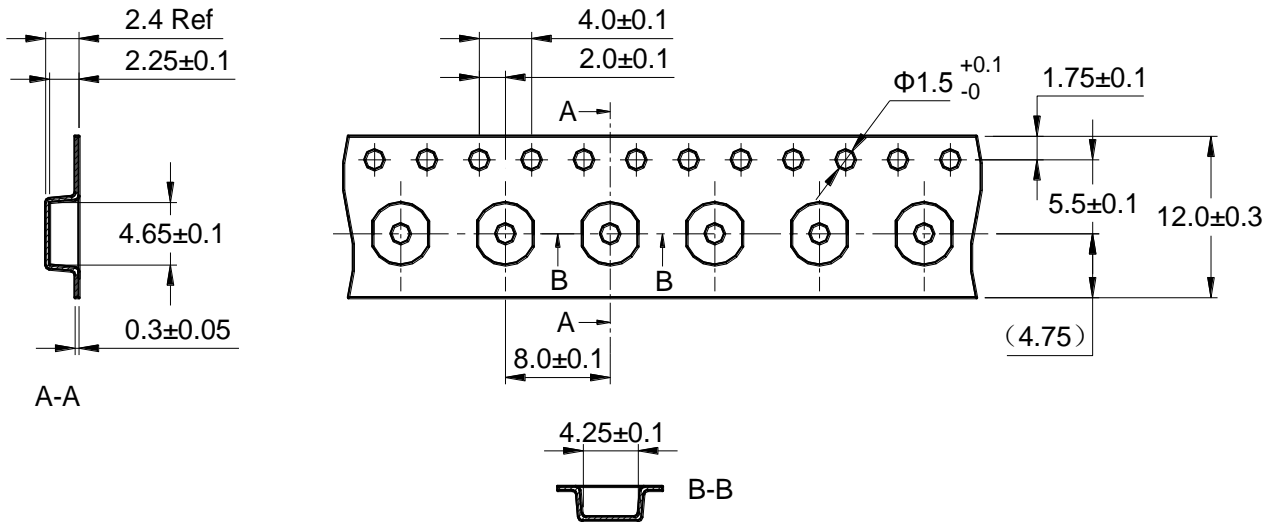

※ Packing is referred to the international standard IEC 60286-3.
包装参照国际标准 IEC 60286-3。

7.2 Tape direction

捆包方向

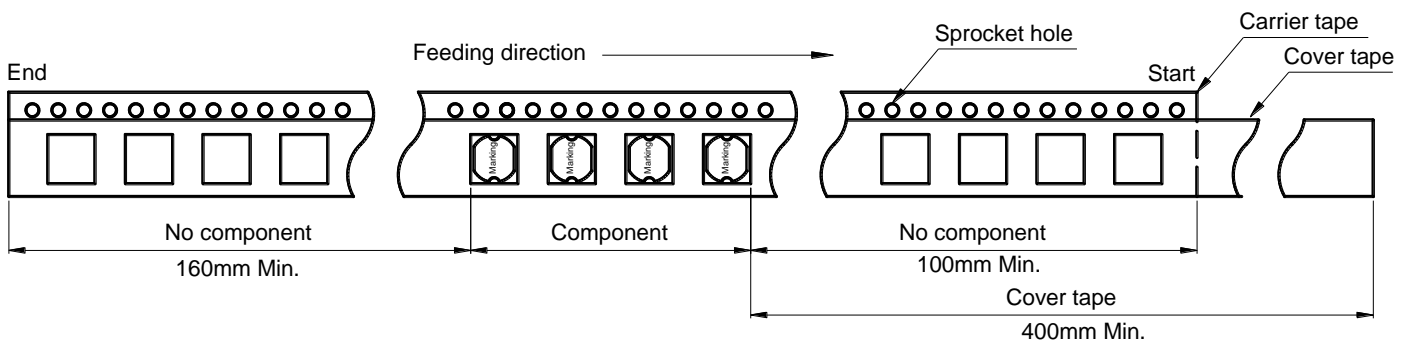

7.3 Cover tape peel off condition

盖带剥离条件

- Cover tape peel force shall be 0.1 to 1.3N.
盖带剥离力度为 0.1~1.3N。
- Reference peel speed 300±10mm/min.
参考剥离速度 300±10mm/分钟。

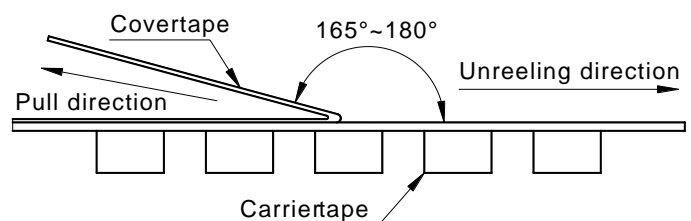

7.4 Reel dimensions (mm)

卷盘尺寸

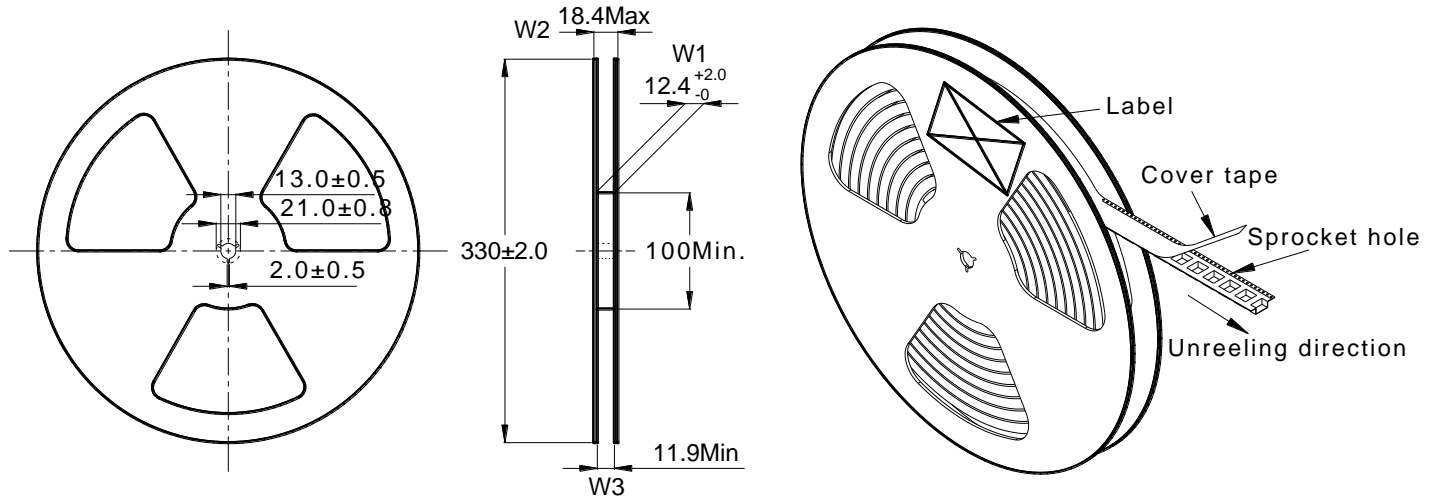

7.5 Carton dimensions and packing quantity

包装箱尺寸和包装数量

■ Inner Carton: 365×345×105mm
内包装盒

■ Out Carton : 385×365×245mm
外包装箱

Product Series 产品系列	Quantity / Reel 数量 / 卷	Inner Carton Quantity 内盒 包装数量	Out Carton Quantity 外箱 包装总数量
SP42	3000pcs	(3000×5) = 15000pcs	(15000×2) = 30000pcs

7.6 Label making

标签标识

The following items will be marked on the reel of product label and shipping label.
以下项目将明确标识于产品卷盘标签以及运输标签上。

Production Label 产品标签
■ Part No. 产品型号
■ Electrical Information 产品电性信息
■ Quantity 数量
■ Packing No. 包装流水号

Shipping Label 运输标签
■ Customer Name 客户名称
■ Customer Part No. 客户型号
■ Supplier Part No. 供应商型号
■ Supplier Name 供应商名称
■ Country of origin 产品产地

8 Soldering specification

焊接规格

8.1 Reflow profile for SMT components

SMT 回流焊温度曲线

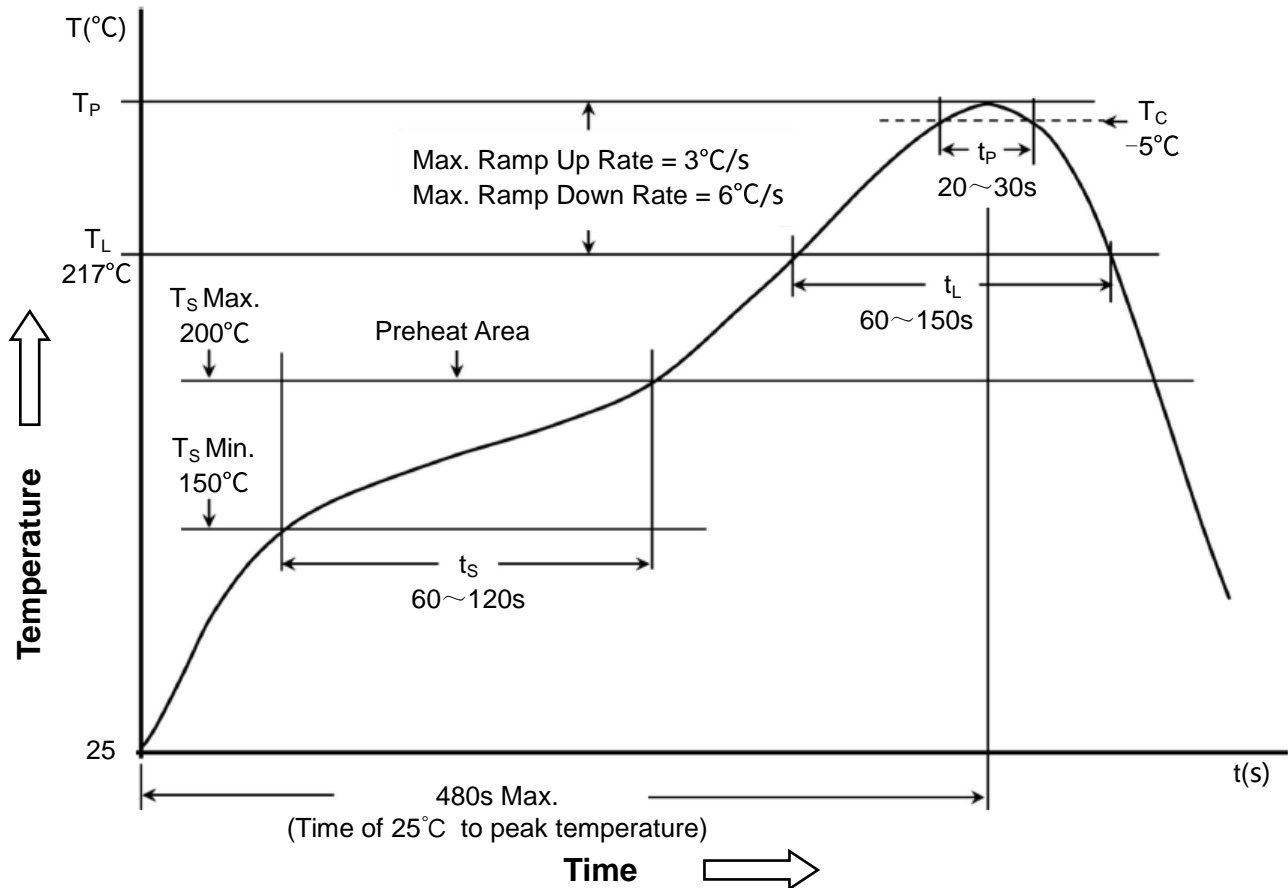

8.2 Classification of peak package body temperature (Tp)

封装体峰值温度(Tp)分类

	Package Thickness 封装厚度	Package Volume 封装体积		
		<350 mm ³	350~2000 mm ³	>2000 mm ³
PB-Free Assembly 无铅装配	<1.6mm	260°C	260°C	260°C
	1.6~2.5mm	260°C	250°C	245°C
	≥2.5mm	250°C	245°C	245°C

※ Reflow is referred to standard IPC/JEDEC J-STD-020D.
回流焊参照标准 IPC/JEDEC J-STD-020D.