

REVISION RECORD			
REV	EON	DESCRIPTION	DATE

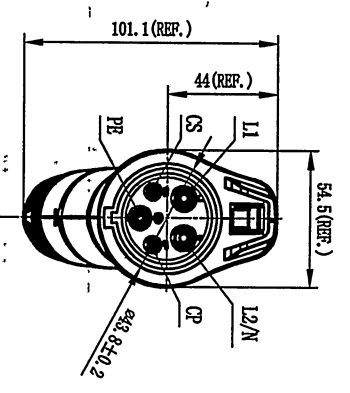

Wiring diagram

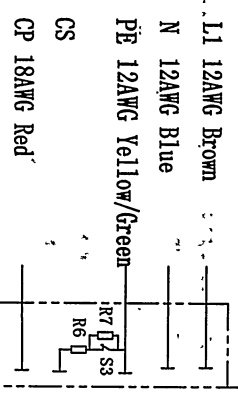

R6=150Ω±3%
R7=330Ω±3%

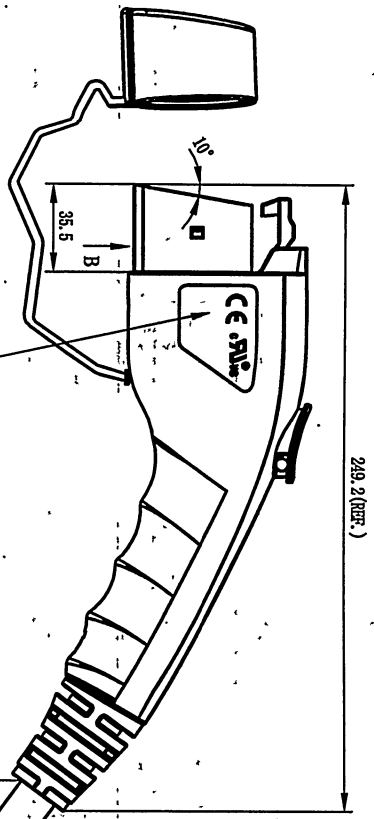

Laser Printing, Front Note:

Laser Printing Back Note (Arial):
 MAAC-S-016A-V-03-7, 2M-11AH
 16A 240V AC
 SAE J1772:2017
 Type 3S
 201xxxx-xxxx

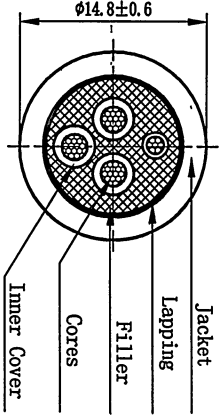
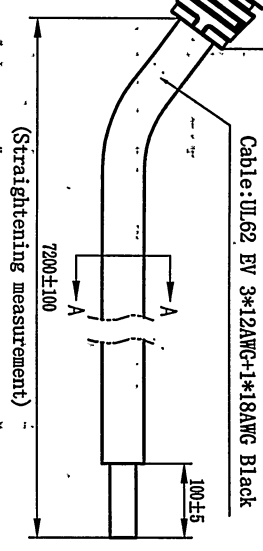

SEC A-A

NOTES:

1. Cable: UL62 EV 3*12AWG+1*18AWG Black
2. RoHS Compliance

MAACSO16AV037, 2M11AH

Housing Colour

Customer Drawing

Technical parameters	
Rated voltage	240V AC
Rated current	16A
Temperature range	-30℃~+50℃
Insulate resistance	>5MΩ, 500V DC 1Min
Withstanding voltage	L, N AND PE, 2500V AC 1Min
Ingress protection	Type 3S
The insertion/pullout times	10000 TIMES
Insertion/pullout force	<75N
Reference standard	SAEJ1772:2017

Size Measure Range	.XX	.X
≤6	±0.05	±0.10
6~30	±0.10	±0.20
30~120	±0.15	±0.30
120~400	±0.20	±0.50
400~1000	±0.30	±0.80
1000~2000	±0.50	±1.20
Angle Measure Range	.XX	.X
	±0.5°	±1.0°

DEGSON® NINGBO DEGSON ELECTRICAL CO., LTD 宁波高松电子有限公司	NAME: Vehicle Connector (16A AC single phase) MAAC-S-016A-V-03-7, 2M-11AH
APP: 2X 20190924	DRFT: XF LUO-2019-09-24
CHHO:	DRWTING NO.: /
THIRD ANGLE PROJECTION	DO NOT SCALE DRAWING
SCALE: 1:3	SHEET: 1/1
SCALE: 1:3	REV: DO-1