

**MOS Memories****FUJITSU****■ MBM27128-20, MBM27128-25, MBM27128-30**

UV Erasable 131,072-Bit  
Read Only Memory

**Description**

The Fujitsu MBM27128 is a high speed 131,072-bit static N-channel MOS erasable and electrically reprogrammable read only memory (EPROM). It is especially well suited for applications where rapid turn-around and/or bit pattern experimentation are important.

A 28-pin dual in-line package or leadless chip carrier (32-pin) with a transparent lid is used to package the MBM27128. The transparent lid allows the user to expose the device to ultraviolet light in order to erase the memory bit pattern previously programmed. At the completion of erasure, a new pattern can then be written into the memory.

The MBM27128 is fabricated using N-channel double polysilicon gate technology with single transistor stacked gate cells. It is organized as 16,384 words by 8-bits for use in microprocessor applications. Single +5V operation greatly facilitates its use in single supply systems.

**Features**

- Organized as 16,384 x 8 fully decoded
- Low power requirement: [550 mW (act), 193 mW (standby)]
- No clocks required (fully static operation)
- Programmable utilizing the Quick Pro™ Algorithm
- Program compatible with the Intel Intelligent Programming™ Algorithm
- Fast Access Time:  
MBM27128-20 200 ns max.  
MBM27128-25 250 ns max.  
MBM27128-30 300 ns max.
- TTL compatible Inputs/outputs
- Three-state output with OR-tie capability
- Output Enable  $\bar{G}$  pin provides precise control of the data bus
- Single +5V operation
- Standard 28-pin DIP package
- Pin compatible with Intel 27128

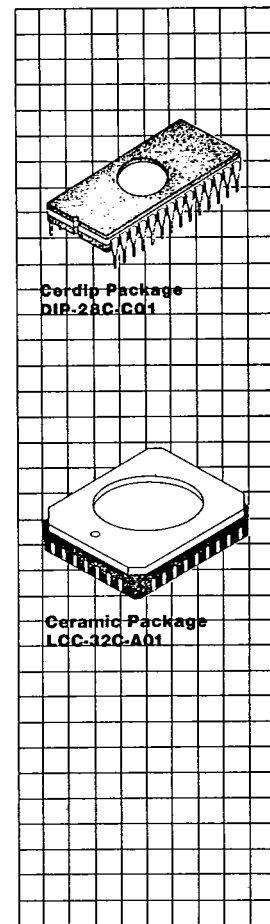

Quick Pro™ is a trademark of Fujitsu Microelectronics Inc.  
Intelligent Programming™ is a trademark of Intel Corporation.

**MBM27128-20**  
**MBM27128-25**  
**MBM27128-30**

**MBM27128 Block Diagram and Pin Assignments**

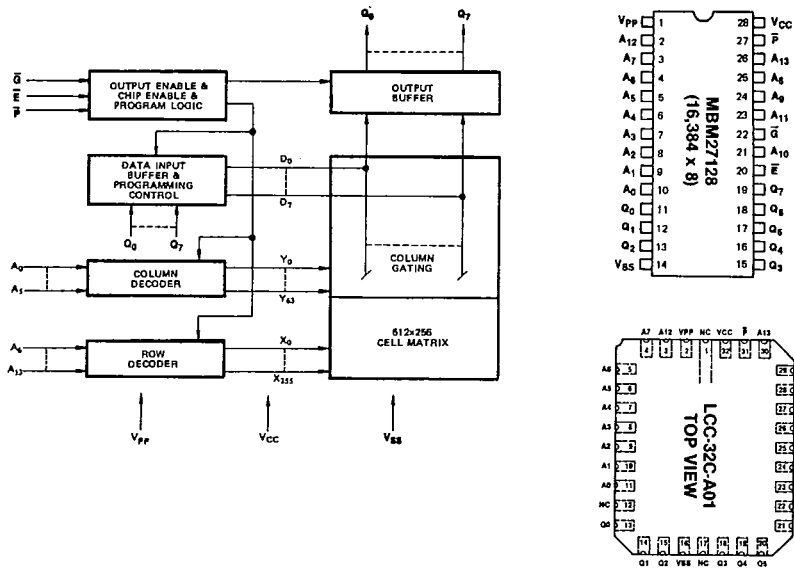

**Absolute Maximum Ratings**  
 (See Note)

Parameter	Symbol	Unit
Temperature Under Bias	$T_A$	-25 to +85 °C
Storage Temperature	$T_{sig}$	-65 to +125 °C
Inputs/Outputs with Respect to $V_{SS}$	$V_{IN}, V_{OUT}$	-0.6 to +7 V
$V_{PP}$ with Respect to $V_{SS}$	$V_{PP}$	-0.6 to +22 V
$V_{CC}$ with Respect to $V_{SS}$	$V_{CC}$	-0.6 to +7 V

Note: Permanent device damage may occur if ABSOLUTE MAXIMUM RATINGS are exceeded. Functional operation should be restricted to the conditions as detailed in the operations sections of this data sheet. Exposure to absolute maximum rating conditions for extended periods may affect device reliability. This device contains circuitry to protect the inputs against damage due to high static voltages or electric fields. It is advised that normal precautions be taken to avoid application of any voltage higher than maximum rated voltages to this high impedance circuit.

**Functions and Pin Connections**

Mode	Function (DIP Pin No.)					
	Address Input $A_0-A_{13}$ (2-10, 23-26, 21)	Data $Q_0-Q_7$ (11-13, 15-19)	$\bar{E}$ (20)	$\bar{G}$ (22)	$\bar{P}$ (27)	$V_{CC}$ $V_{PP}$ $V_{SS}$ (28) (1) (14)
Read	$A_{IN}$	$D_{OUT}$	$V_{IL}$	$V_{IL}$	$V_{IH}$	$V_{CC}$ $V_{CC}$ $V_{SS}$
Output Disable	Don't Care	High Z	$V_{IL}$	$V_{IH}$ Don't Care	Don't Care $V_{IL}$	$V_{CC}$ $V_{CC}$ $V_{SS}$
Stand by	Don't Care	High Z	$V_{IH}$	Don't Care	Don't Care	$V_{CC}$ $V_{CC}$ $V_{SS}$
Program	$A_{IN}$	$D_{IN}$	$V_{IL}$	$V_{IH}$	$V_{IL}$	$V_{CC}$ $V_{PP}$ $V_{SS}$
Program Verify	$A_{IN}$	$D_{OUT}$	$V_{IL}$	$V_{IL}$	$V_{IH}$	$V_{CC}$ $V_{PP}$ $V_{SS}$
Program Inhibit	Don't Care	High Z	$V_{IH}$	Don't Care	Don't Care	$V_{CC}$ $V_{PP}$ $V_{SS}$

FUJITSU

MBM27128-20  
MBM27128-25  
MBM27128-30

**Capacitance**(T<sub>A</sub> = 25°C, f = 1MHz)

Parameter	Symbol	Min	Typ	Max	Unit
Input Capacitance (V <sub>IN</sub> = 0V)	C <sub>IN</sub>	—	4	6	pF
Output Capacitance (V <sub>OUT</sub> = 0V)	C <sub>OUT</sub>	—	8	12	pF

**Recommended Operating Conditions**(Referenced to V<sub>SS</sub>)

Parameter	Symbol	Min	Typ	Max	Unit	Operating Temperature
V <sub>CC</sub> Supply Voltage	V <sub>CC</sub>	4.5	5.0	5.5	V	0°C to +70°C
V <sub>PP</sub> Supply Voltage	V <sub>PP</sub>	V <sub>CC</sub> - 0.6	—	V <sub>CC</sub> + 0.6	V	
Input High Voltage	V <sub>IH</sub>	2.0	—	V <sub>CC</sub> + 1	V	
Input Low Voltage	V <sub>IL</sub>	-0.1	—	0.8	V	

**DC Characteristics**

(Recommended operating conditions unless otherwise noted.)

Parameter	Symbol	Min	Typ	Max	Unit
Input Load Current (V <sub>IN</sub> = 5.5V)	I <sub>LI</sub>	—	—	10	μA
Output Leakage Current (V <sub>OUT</sub> = 5.5V)	I <sub>LO</sub>	—	—	10	μA
V <sub>CC</sub> Standby Current ( $\bar{E} = V_{IH}$ )	I <sub>CC1</sub>	—	—	35	mA
V <sub>CC</sub> Supply Current ( $\bar{E} = V_{IL}$ )	I <sub>CC2</sub>	—	—	100	mA
V <sub>PP</sub> Supply Current (V <sub>PP</sub> = V <sub>CC</sub> ± 0.6V)	I <sub>PP</sub>	—	—	5	mA
Output Low Voltage (V <sub>OL</sub> = 2.1mA)	V <sub>OL</sub>	—	—	0.45	V
Output High Voltage (I <sub>OH</sub> = -400μA)	V <sub>OH</sub>	2.4	—	—	V

**AC Characteristics**

(Recommended operating conditions unless otherwise noted.)

Parameter	Symbol		MBM27128-20		MBM27128-25		MBM27128-30		Unit
	Alternate	Standard*	Min	Max	Min	Max	Min	Max	
Address Access Time	t <sub>ACC</sub>	TAVQV		200		250		300	ns
$\bar{E}$ to Output Delay	t <sub>CE</sub>	TELQV		200		250		300	ns
$\bar{G}$ to Output Delay	t <sub>OE</sub>	TGLQV		70		100		120	ns
Address to Hold Time	t <sub>OH</sub>	TAXQX	0		0		0		ns
$\bar{E}$ or $\bar{G}$ High to Output Float	t <sub>DF</sub>	TGHQZ, TEHQZ	0	60	0	60	0	105	ns

**AC Test Conditions**  
(Including programming)

Input Pulse levels: 0.8V to 2.2V  
 Input Rise and Fall Time: ≤ 20nsec  
 Timing Measurement Reference Levels: 1.0V and 2.0V for Inputs  
 0.8V and 2.0V for outputs  
 Output Load: 1 TTL gate and C<sub>L</sub> = 100 pF

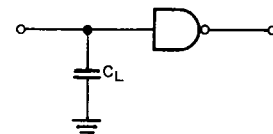

FUJITSU



MBM27128-20  
 MBM27128-25  
 MBM27128-30

**Programming/Erasure Information, continued**

**"Quick Pro™" Programming**

In addition to the standard 50 millisecond pulse width programming procedure, the MBM27128 can be programmed with a fast programming algorithm designed by Fujitsu called Quick Pro™. The algorithm (shown in Figure 3) utilizes a sequence of 1 millisecond pulse to program each location. This algorithm will typically yield a savings of 86% in programming time per device when utilized in commercially available programmers. However, in custom programmer designs that require less overhead the savings can be even greater.

The programming mode is entered when +6V is applied to the VCC pin followed by applying +21V to VPP pin. A TTL low input must be applied to the E input and a TTL high input must be applied to the G input. After the programming voltages and TTL levels have stabilized, a sequence of 1 millisecond pulses must be applied to the P pin for programming. After each pulse, a pulse counter must be incremented and the location should be checked for accuracy. Upon verification, an additional sequence of 1 millisecond pulses equal to the present value of the pulse counter must be applied to the location to ensure proper levels of stored charge. An alternate approach to the additional pulses would be to apply a single TTL low pulse with a width equivalent to the value of the pulse counter multiplied by 1 millisecond. When the pulse counter reaches a maximum of 20, the verification procedure is skipped and a flag is set to indicate a program failure. Upon completion of programming of the entire device, a final array verification (all locations) is required. All Fujitsu devices will typically require only two 1 millisecond pulses (one initial and one additional) to reach sufficient stored charge levels.

**Erasure**

In order to clear all locations of their programmed contents,

It is necessary to expose the MBM27128 to an ultraviolet light source. A dosage of 15W-seconds/cm<sup>2</sup> is required to completely erase an MBM27128. This dosage can be obtained by exposure to an ultraviolet lamp (wavelength of 2537 Angstroms (Å) with intensity of 12,000μW/cm<sup>2</sup> for 15 to 20 minutes. The MBM27128 should be about one inch from the source and all filters should be removed from the UV light source prior to erasure.

MBM27128 and similar devices, will erase with light sources having wavelengths shorter than 4000 Å. Although erasure times will be much longer than with UV sources at 2537 Å, nevertheless, the exposure to fluorescent light and sunlight will eventually erase the MBM27128 and such exposure should be prevented to realize maximum system reliability. If used in such an environment, the package windows should be covered by an opaque label or substance.

It is important to note that the

**Figure 3. — Quick Pro™ Flow Chart**

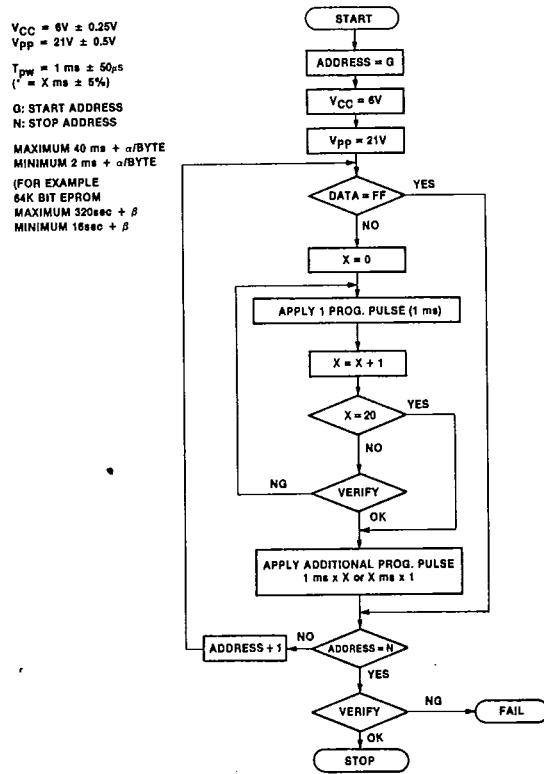

VCC = 6V ± 0.25V  
 Vpp = 21V ± 0.5V  
 T<sub>pw</sub> = 1 ms ± 50ps  
 (" = X ms ± 5%)  
 G: START ADDRESS  
 N: STOP ADDRESS  
 MAXIMUM 40 ms + α/BYTE  
 MINIMUM 2 ms + α/BYTE  
 (FOR EXAMPLE  
 64K BIT EPROM  
 MAXIMUM 320sec + β  
 MINIMUM 16sec + β)

QUICK PRO™ IS A TRADEMARK OF FUJITSU LIMITED

MBM27128-20  
 MBM27128-25  
 MBM27128-30

**Programming Characteristics**

**DC Characteristics**

( $T_A = 25 \pm 5^\circ\text{C}$ ,  
 $V_{CC} = 5V \pm 5\%$  (Conventional),  
 $V_{CC} = 6V \pm 0.25V$  (Quick Pro™),  
 $V_{PP} = 21V \pm 0.5V$ )

Parameter	Symbol	Min	Max	Unit	Test Conditions
Input Leakage Current	$I_{LI}$	—	10	$\mu\text{A}$	$V_{IN} = 5.25V/0.45V$
$V_{PP}$ Supply Current During Programming Pulse	$I_{PP2}$	—	30	mA	$\bar{E} = \bar{P} = V_{IL}$
$V_{PP}$ Supply Current During Verify	$I_{PP3}$	—	5	mA	$\bar{E} = V_{IL}, \bar{P} = V_{IH}$
$V_{PP}$ Supply Current Program Inhibit (Active)	$I_{PP4}$	—	5	mA	$\bar{E} = V_{IH}$
$V_{CC}$ Supply Current Program Inhibit	$I_{CC1}$	—	35	mA	$\bar{E} = V_{IH}$
$V_{CC}$ Supply Current Program & Verify	$I_{CC2}$	—	100	mA	—
Input Low Voltage	$V_{IL}$	-0.1	+0.8	V	—
Input High Voltage	$V_{IH}$	2.0	$V_{CC} + 1$	V	—
Output Low Voltage During Verify	$V_{OL}$	—	0.45	V	$I_{OL} = 2.1 \text{ mA}$
Output High Voltage During Verify	$V_{OH}$	2.4	—	V	$I_{OH} = -400\mu\text{A}$

**Note 1.**  $V_{CC}$  must be applied either coincidentally or before  $V_{PP}$  and removed either coincidentally or after  $V_{PP}$ .

**Note 2.**  $V_{PP}$  must not be greater than 21.5 volts including overshoot. Permanent device change may occur if the device is taken out or put into socket remaining  $V_{PP} = 21$  volts. Also, during  $\bar{E} = \bar{P} = V_{IL}$ ,  $V_{PP}$  must not be switched from  $V_{CC}$  to 21 volts or vice-versa.

**AC Characteristics**

( $T_A = 25 \pm 5^\circ\text{C}$ ,  
 $V_{CC} = 5V \pm 5\%$  (Conventional),  
 $V_{CC} = 6V \pm 0.25V$  (Quick Pro™),  
 $V_{PP} = 21V \pm 0.5V$ )

Parameter	Symbol	Min	Typ	Max	Unit
Address Setup Time	TAVPL	2	—	—	$\mu\text{s}$
Chip Enable Setup Time	TELPL	2	—	—	$\mu\text{s}$
Output Enable Time	TDZGL	2	—	—	$\mu\text{s}$
Data Setup Time	TDVPL	2	—	—	$\mu\text{s}$
Address Hold Time	TGHAX	0	—	—	$\mu\text{s}$
Data Hold Time	TPHDZ	2	—	—	$\mu\text{s}$
Output Enable to Output Float Delay	TGHQZ	—	—	130	ns
Data Valid from Output Enable	TGLQV	—	—	150	ns
$V_{PP}$ Setup Time	TVPPHPL	2	—	—	$\mu\text{s}$
$\bar{P}$ Pulse Width-Conventional	TPLPH	25	50	55	ms
$\bar{P}$ Pulse Width-Quick-Pro™	TPLPH	0.95	1.00	1.05	ms

**Note 1**  $TPHDZ + TDZGL \geq 50\mu\text{s}$ .

**Programming Waveform**

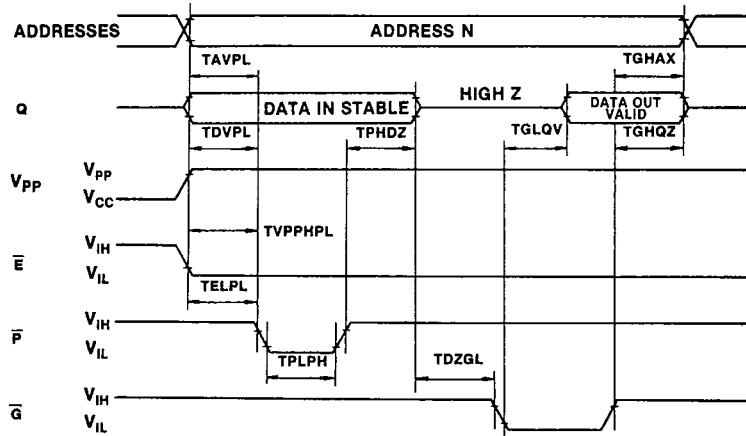

FUJITSU

