



2T8A3_1.5UP series

2W - Single Output DC-DC converter - Fixed Input - Isolated & Unregulated

DC-DC Converter

2 Watt

- ⊕ Fixed input voltage, isolated & unregulated
- ⊕ 2W output power
- ⊕ Continuous short circuit protection
- ⊕ Operating temperature: -40°C to +105°C
- ⊕ Small SMD8 package, International standard pin-out
- ⊕ 1500VDC isolation voltage
- ⊕ Up to 86% efficiency
- ⊕ No load input current as low as 5mA
- ⊕ ESD meets contact 8kV

Introducing our new 2T8A3_1.5UP series, designed with a fixed input voltage and providing an isolated, unregulated output for reliable performance. Delivering 2W of output power, this module is equipped with continuous short circuit protection, ensuring stable operation and safeguarding your system from unexpected faults. Operating within a wide temperature range of -40°C to +105°C, the module is built for durability in demanding environments. Its small SMD8 package and international standard pin-out make it easy to integrate into space-constrained designs, while offering the flexibility needed for various applications. With a 1500VDC isolation voltage and up to 86% efficiency, this module optimizes both safety and energy usage. The no-load input current is as low as 5mA, contributing to its overall efficiency and energy-saving capabilities.



Common specifications	
Short circuit protection	Continuous, self-recovery
Switching frequency	Full load 3.3VDC/5VDC input 260 kHz Full load 12VDC/24VDC input 450 kHz
Operating temperature	-40°C - +105°C (with derating)
Storage temperature	-55°C - +135°C
Reflow temperature	Peak value temperature Tc ≤250°C, maxi time is 60s for temperature over 217°C
Case temperature rise	15°C (typ.) (test environment temperature 25°C)
Pin withstand welding temp	300°C (max.) distance to case 1.5 mm, 10 seconds
Relative humidity	95% RH (non-condensing)
Hot plug	Unavailable
MTBF (MIL-HDBK-217F@25°C)	3,000,000 Hours
Case material	Black flame-retardant heat-resistant plastic (UL94 V-0)
Cooling Method	Natural air cooling
Packing Dimension	12.7 x 11.20 x 7.25mm
Weight	1.4g (typ.)

Output specifications						
Item	Operating condition	Min	Typ	Max	Units	
Output voltage accuracy	See regulation curve					
Load regulation (10%-100% load)	3.3VDC/5VDC output Other voltage output		15 10	20 15	%	
Line regulation (input voltage change ±1%)	3.3VDC/5VDC output Other voltage output			±1.5 ±1.2	%	
Temperature drift coefficient	Full load		±0.03		%/°C	

Isolation specifications						
Item	Operating Conditions	Min	Typ	Max	Units	
Insulation withstand voltage	Input-output, test 1min, leakage current ≤0.5mA	1500			VDC	
Insulation resistance	Input-output, Insulation Voltage 500VDC	1000			MΩ	
Isolation capacitor	Input-output, 100kHz/0.1V		20		PF	

Input specifications						
Item	Operating condition	Min	Typ	Max	Units	
Input current (full load/no load)	3.3VDC Input					
	• 3.3VDC output		758/10	777/15		
	• 5VDC/ 9VDC output		739/20	758/25		
	• 12VDC output		722/30	739/35		
	• 24VDC output		758/40	777/50		
	5VDC output					
	• 3.3VDC output		500/5	513/12		
	• 5VDC output		476/5	488/12		
	• 9VDC output		465/10	476/20		
	• 12VDC output		455/20	465/30		
	• 24VDC output		488/30	500/40		
	12VDC Input					
• 5VDC output		200/8	235/15			
• 12VDC output		190/8	235/15			
24VDC input						
• 5VDC output		100/8	120/15			
• 12VDC output		98/8	120/15			
• 24VDC output		96/8	120/15			
Reflected ripple Current			15		mA	
Overshoot voltage	3.3VDC Input	-0.7		9		
	5VDC Input	-0.7		11		
	12VDC Input	-0.7		18		
	24VDC Input	-0.7		30		
Overshoot current			0.8		A	

EMC Characteristic			
EMI	CE	CISPR32/EN55032 CLASS B (See EMC recommended circuit below)	
EMI	RE	CISPR32/EN55032 CLASS B (See EMC recommended Circuit below)	
EMS	ESD	IEC/EN61000-4-2 Air ±8kV, Contact ±8kV perf. Criteria B	

Example:
2T8A3_0512S1.5UP
2 = 2Watt; T8 = SMT8; A3 = Pinning; 05 = 5Vin; 12 = 12Vout;
S = Single Output; 1.5 = 1.5kVDC isolation; U = Unregulated Output;
P = Short circuit protection

1. If the product is operated under the min. required load, the product performance cannot be guaranteed to comply with all performance indexes in this datasheet;
2. The maximum capacitive load is tested under nominal input voltage range and full load condition;
3. Unless otherwise specified, data in this datasheet are tested under conditions of Ta = 25°C, humidity <75% when inputting nominal voltage and outputting rated load (pure resistance load);
4. All index testing methods in this datasheet are based on our company's corporate standards.
5. We can provide customized product service;

2T8A3_1.5UP series

2W - Single Output DC-DC converter - Fixed Input - Isolated & Unregulated

Product Selection Guide

Approval	Part number	Input Voltage Range (VDC)	Output Voltage (VDC)	Output Current Max./Min (mA)	Max. Capacitive Load (uF)	Ripple & Noise 20MHz (typ/max) (mVp-p)	Efficiency (typ) (%)
	2T8A3_0305S1.5UP	3.3	5	400/40	2400	50/100	82
	2T8A3_0503S1.5UP	5	3.3	600/60	2400	50/100	80
	2T8A3_0505S1.5UP	5	5	400/40	2400	50/100	83
	2T8A3_0509S1.5UP	5	9	222/22	2400	50/100	85
	2T8A3_0512S1.5UP	5	12	167/17	2400	80/100	86
	2T8A3_1205S1.5UP	12	5	400/40	2400	80/100	84
	2T8A3_1212S1.5UP	12	12	167/17	2400	80/100	86
	2T8A3_1505S1.5UP	15	5	400/40	2400	80/100	82
	2T8A3_1512S1.5UP	15	12	167/17	560	80/100	84
	2T8A3_1515S1.5UP	15	15	133/13	560	80/100	84
	2T8A3_2405S1.5UP	24	5	400/40	2400	80/100	84
	2T8A3_2412S1.5UP	24	12	167/17	560	80/100	86
	2T8A3_2424S1.5UP	24	24	83/8	470	80/150	84

Note:

1. The typical output efficiency is based on that product is full loaded and burned-in after half an hour.
2. The fluctuation range of full load efficiency (% , typ) is $\pm 2\%$, full load output efficiency = total output power/module's input power.

Product characteristic curve

Output regulation curve

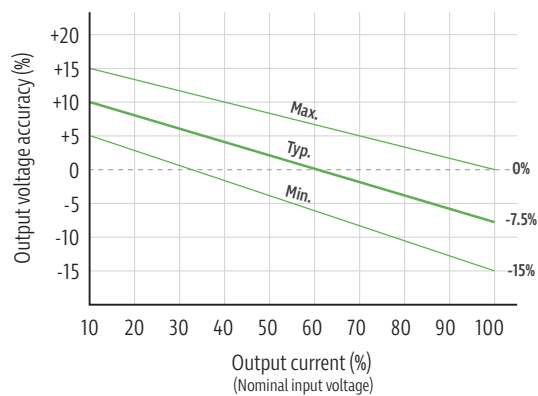

Output regulation curve

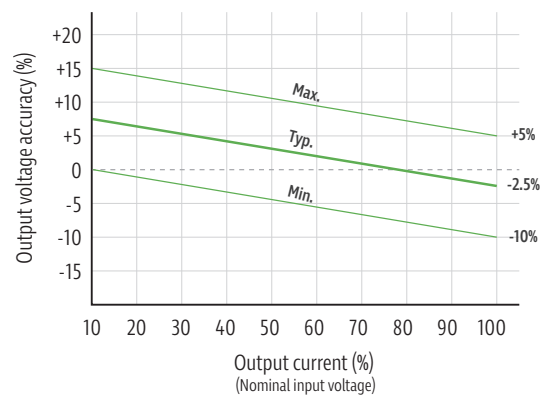

Temperature derating graph

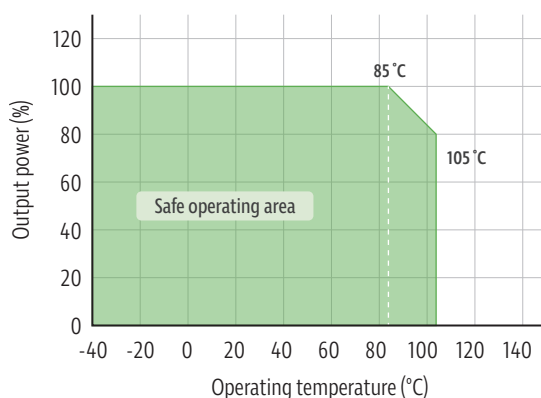

2T8A3_1.5UP series

2W - Single Output DC-DC converter - Fixed Input - Isolated & Unregulated

Typical application circuit

In order to ensure the input/output ripple and noise decreased, capacitor filter net could be connected to input and output side, application circuit as below photo 3; choosing suitable filter capacitor is very important, start-up problems may be caused by too large capacitance.



Note 1: Cin is 4.7uF/50V, Cout is 10uF/50V

EMC typical recommended circuit

In order to ensure the input/output ripple and noise decreased, capacitor filter net could be connected to input and output side, application circuit as below photo 3; choosing suitable filter capacitor is very important, start-up problems may be caused by too large capacitance.

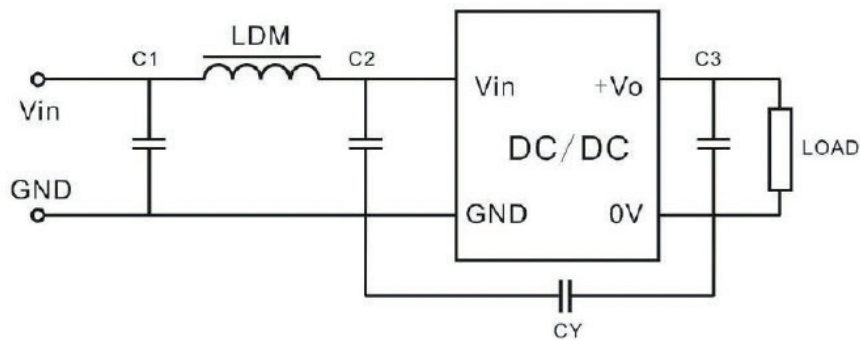

Output Load Requirement

In order to ensure the converter can work reliably with high efficiency, the minimum load should not less than 10% rated load when it is used. If the needed power is indeed small, please parallel a resistor at the output side. The actual using power and the power of the resistor should be more than 10% rated power.

2T8A3_1.5UP series

2W - Single Output DC-DC converter - Fixed Input - Isolated & Unregulated

Mechanical dimensions

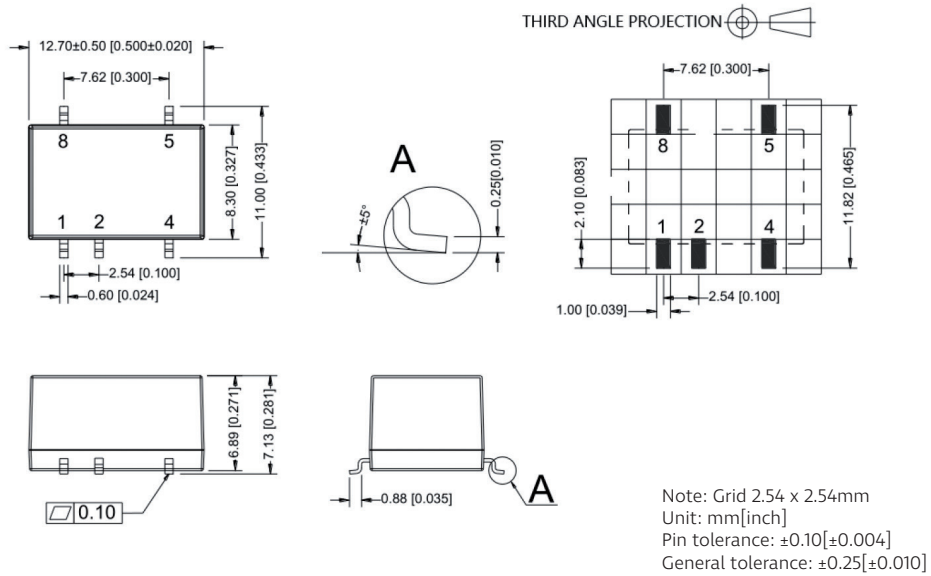

Pin-Out	1	2	4	5	8
Function	-Vin	+Vin	GND	+Vo	NC

NC pin: do not connect to any external circuit

Note: if the definition of pin is not in accordance with the model selection manual, please refer to the label on actual item.

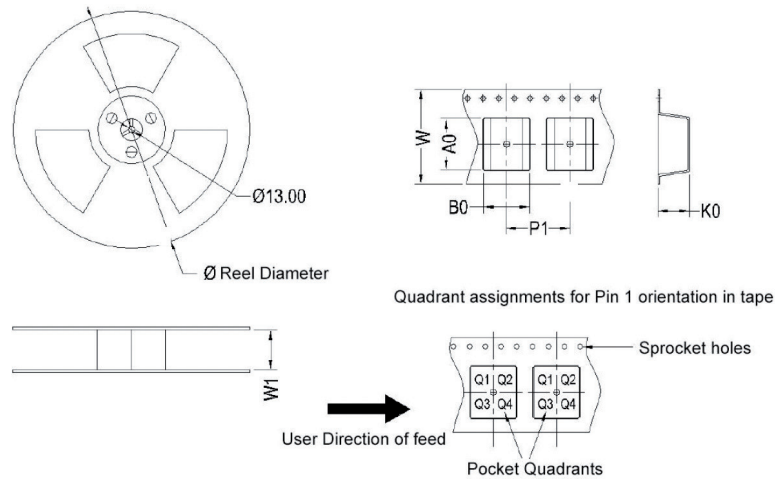

Device	Package Type	PIN	SPQ	Reel Diameter (mm)	Reel Width (mm)	A0 (mm)	B0 (mm)	K0 (mm)	P1 (mm)	W (mm)	PIN1 Quadrant
2T8A3_xxyy51.5UP	SMD	5	500	330	24.5	13.1	11.7	7.5	16.0	24	Q1

NC pin: do not connect to any external circuit