



3ACOS_SR1 series

3W - AC-DC converter

AC-DC Converter

3 Watt

- ⊕ Wide input voltage range: 85-305VAC/70-430VDC
- ⊕ No load power consumption $\leq 0.40W$
- ⊕ Up to 73% efficiency
- ⊕ Protections: Short circuit, over current
- ⊕ Ultra-small bare board, high efficiency, high reliability
- ⊕ Industrial-grade product technology design
- ⊕ PCB mounting
- ⊕ Operating temperature: $-40^{\circ}C$ to $+85^{\circ}C$

Introducing our ultra-compact and highly reliable 3ACOS_SR1 series, designed with advanced industrial-grade product technology. This unit features a wide input voltage range of 85-305VAC or 70-430VDC, accommodating a variety of power inputs and ensuring versatility in application. Its no load power consumption is remarkably low at $\leq 0.40W$, which contributes to an overall efficiency of up to 73%. Built for performance and durability, this bare board power supply includes robust protections against short circuits and overcurrent events, enhancing safety and longevity. Its ultra-small footprint and PCB mounting design make it ideal for integration into existing systems where space is at a premium.

Engineered to withstand extreme conditions, it operates effectively across a wide temperature range from $-40^{\circ}C$ to $+85^{\circ}C$, making it suitable for challenging industrial environments.



Common specifications

Short circuit protection	Full input voltage range - continuous, self-recovery hiccup
Over current protection	Full input voltage range - $\geq 110\%$ lo self-recovery hiccup
Operating temperature	$-40^{\circ}C$ - $+85^{\circ}C$ (with derating)
Storage temperature	$-40^{\circ}C$ - $+105^{\circ}C$
Soldering temperature	Wave-soldering $260^{\circ}C$ ($\pm 4^{\circ}C$), timing 5 - 10s Manual-soldering $360^{\circ}C$ ($\pm 8^{\circ}C$), timing 4 - 7s
Relative humidity	95% RH
Hot plug	Unavailable
Safety standard	IEC/UL62368-1
MTBF (MIL-HDBK-217F@ $25^{\circ}C$)	>1,000,000 Hours

Input specifications

Item	Operating condition	Min	Typ	Max	Units
Input voltage range	AC input	85	220	305	VAC
	DC input	70	310	430	VDC
Input frequency range		47	50	63	Hz
Input current	115VAC			0.12	A
	277VAC			0.06	A
Surge current	115VAC		25		A
	277VAC		40		A
Recommended external input Fuse	1A/300VAC slow fusing, necessary				

Output specifications

Item	Operating condition	Min	Typ	Max	Units
Voltage accuracy (Full input voltage range, 10%~100% load)	$V_o = 12V$		± 1.5	-7~+3	%
			± 2.5	-5~+8	
Line Regulation (Nominal load)	$V_o = 12V$		± 1.5	± 2.5	%
			± 1.0	± 2.5	
Load regulation (Nominal input voltage, 10%~100% load)	$V_o = 12V$		± 2.5	± 5.5	%
			± 2.0	± 5.5	
No load consumption (Input 230VAC)	$V_o = 12V$			0.3	W
				0.4	
Minimum load	Single Output	10			%
Start-up delay time	Input 230VAC (full load)		1000		mS
Power-off holding time	Input 230VAC (full load)		80		mS
Output overshooting	Full input voltage range			$\leq 10\%V_o$	%
Temperature drift			$\pm 0.12\%$		%/ $^{\circ}C$

- The product should be used within the specification range, or it will cause permanent damage to it;
- The input terminal should connect to fuse;
- If the product is worked under the minimum requested load, the product performance cannot be guaranteed to comply with all parameters in the datasheet;
- If the product is not operated within the required load range, the product performance cannot be guaranteed to comply with all parameters in the datasheet;
- Unless otherwise specified, parameters in this datasheet were measured under the conditions of $T_a = 25^{\circ}C$, humidity $< 75\%$ with nominal input voltage and rated output load (pure resistance load);
- All index testing methods in this datasheet are based on our company's corporate standards;
- The performance indexes of the product models listed in this manual are as above, but some indexes of non-standard model products will exceed the above-mentioned requirements, please directly contact our technician for specific information;
- Specifications are subject to change without prior notice, please follow up with our website for latest datasheet.

Example:

3ACOS_05SR1

3 = 3Watt; AC = AC-DC; OS = Series; 05 = 5Vout;
S = Single output; R1 = Revised version

3ACOS_SRI series

3W - AC-DC converter

EMC specifications						
EMC	EMI	CE	CISPR22/EN55032 CISPR22/EN55032	CLASS A (Recommended Circuit 1) CLASS B (Recommended Circuit 2)		
EMC	EMI	RE	CISPR22/EN55032 CISPR22/EN55032	CLASS A (Recommended Circuit 1) CLASS B (Recommended Circuit 2)		
EMC	EMS	RS	IEC/EN61000-4-3	10V/m		Perf.Criteria A (Recommended Circuit 2)
EMC	EMS	CS	IEC/EN61000-4-6	3Vr.m.s		Perf.Criteria A (Recommended Circuit 2)
EMC	EMS	ESD	IEC/EN61000-4-2	Contact ±6kV / Air ±8kV		Perf.Criteria B (Recommended Circuit 1)
EMC	EMS	Surge	IEC/EN61000-4-5	line to line ±1kV		Perf.Criteria B (Recommended Circuit 1)
EMC	EMS	EFT	IEC/EN61000-4-4	±2kV ±4kV		Perf.Criteria B (Recommended Circuit 1) Perf.Criteria B (Recommended Circuit 2)
EMC	EMS	Voltage dips, short interruptions and voltage variations immunity	IEC/EN61000-4-11	0%~70%		Perf.Criteria B (Recommended Circuit 2)

Product Selection Guide

Approval	Part number	Output Power	Output Voltage 1 Vo(V)	Output Current 1 Io(mA)	Max. Capacitive Load (uF)	Ripple & Noise 20MHz mVp-p	Efficiency Full Load, 230VAC Typ. (%)
	3ACOS_12SR1	3	12	250	330	150	73

Note:

1. For non-isolated power supply, there is no isolation protection between the output terminal and the input dangerous voltage terminal, be careful of the contact.
2. The test method for ripple and noise adopts the twisted pair test method. The specific test method and matching can be found in the following (ripple & noise test instructions).
3. The typical value of output efficiency is based on the product being aged for half an hour at full load.
4. The full load efficiency (% typ.) in the table fluctuates by ±2%. The full load efficiency is the total output power divided by the input power of the module.

Product characteristic curve

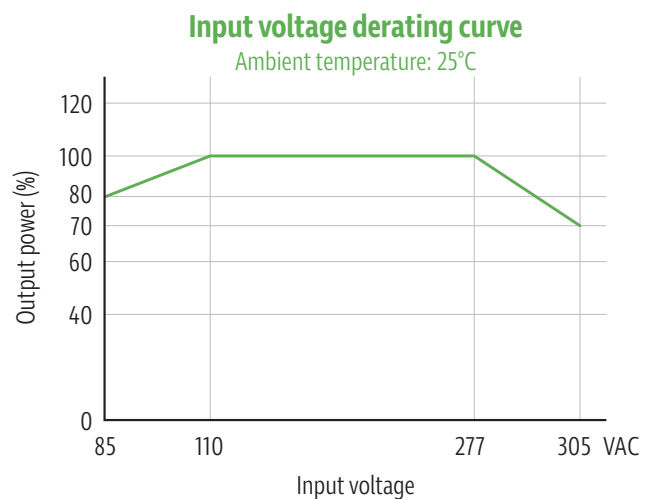
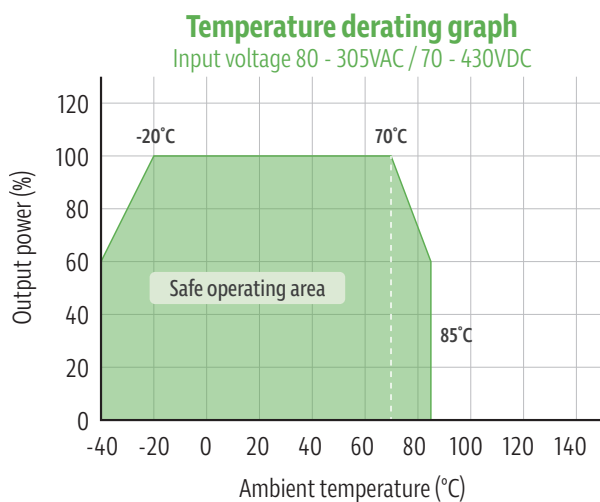

Note

1. Input voltage should be derated based on input voltage derating curve when it is 85~100VAC/277~305VAC and 120~140VDC/ 390~430VDC.
2. Our product is suitable to use under natural air cooling environment, if use it under closed condition, please contact with us.

Mechanical dimensions

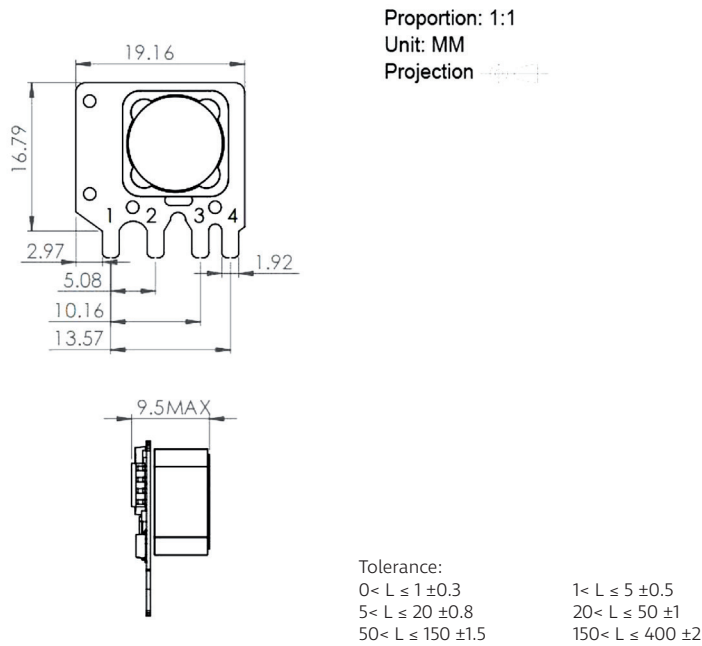

Pin-out	1	2	3	4
Single (S)	AC (L)	+V (CAP)	AC (N)/-Vo	+Vo

Typical application circuit

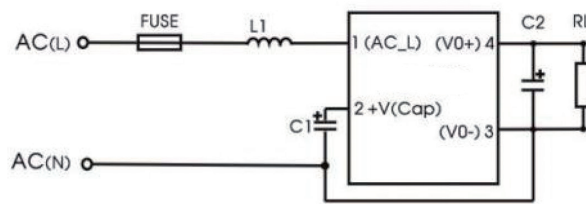

Recommended circuit 1

FUSE (necessary)	L1 (necessary)	C1 (necessary)	C2 (necessary)
1A/300VAC, time delay fuse	1.2mH/0.2A min.	10UF, 400V: 165-264VAC	470UF, 16V
1A/300VAC, time delay fuse	1.2mH/0.2A min.	10UF, 450V: 165-305VAC	470UF, 16V
1A/300VAC, time delay fuse	1.2mH/0.2A min.	22UF, 400V: 85-264VAC	470UF, 16V
1A/300VAC, time delay fuse	1.2mH/0.2A min.	22UF, 450V: 85-305VAC	470UF, 16V

Note:

1. C1 is the input filter electrolytic capacitor (must be externally connected). If the surge immunity index needs to be met, C1 capacitor needs to be connected to 22UF;
 C2 is the output filter electrolytic capacitor (must be externally connected). It is recommended to use a high-frequency low-resistance electrolytic capacitor or a solid-state capacitor;

EMC recommended circuit

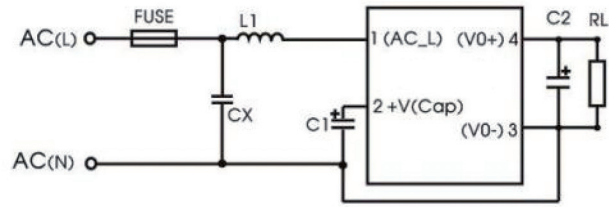

Recommended Circuit 2

FUSE (necessary)	CX (necessary)	L1 (necessary)	C2 (necessary)	C1 (necessary)
1A/300VAC, time delay fuse	X1, 104K/310VAC	1.2mH/0.2A min.	220UF, 16V	10UF, 400V: 165-264VAC
1A/300VAC, time delay fuse	X1, 104K/310VAC	1.2mH/0.2A min.	220UF, 16V	10UF, 450V: 165-305VAC
1A/300VAC, time delay fuse	X1, 104K/310VAC	1.2mH/0.2A min.	220UF, 16V	22UF, 400V: 85-264VAC
1A/300VAC, time delay fuse	X1, 104K/310VAC	1.2mH/0.2A min.	220UF, 16V	22UF, 450V: 85-305VAC