



## 5ACFE1W\_4 series

5W - AC-DC converter

### AC-DC Converter

5 Watt

- ⊕ **Wide input voltage range:** 85-528VAC/100-745VDC
- ⊕ **No load power consumption:** ≤0.4W (230VAC)
- ⊕ **Transfer efficiency:** typ. 78% (230VAC)
- ⊕ **Switching frequency:** 65kHz (typ.)
- ⊕ **Protections:** short circuit and over-current
- ⊕ **Isolation voltage:** 4000VAC
- ⊕ **PCB mounting**

Introducing our versatile 5ACFE1W\_4 series: featuring a wide input voltage range of 85-528VAC/100-745VDC, this converter ensures flexibility and adaptability across various applications. With no-load power consumption of ≤0.4W (230VAC) and a typical transfer efficiency of 78% (230VAC), it delivers reliable and efficient performance.

Operating at a typical switching frequency of 65KHz, the converter includes essential protections against short circuit and over-current. It provides robust isolation with a voltage of 4000VAC and is designed for easy PCB mounting, ensuring seamless integration into your projects.



Common specifications	
Short circuit protection	Long-term short-circuit, self-recovery - Hiccup
Over current protection	Input 230VAC - ≥110% Io self-recovery - Hiccup
Switching frequency	60 KHz (min.) 65 KHz (typ.) 70 KHz (max.)
Operating temperature	-40°C - +85°C (needs to be performed on the basis of the temperature derating curve. The derating curve diagram can be seen in the back - product characteristic curve)
Storage temperature	-40°C - +105°C
Soldering temperature	Wave soldering 260±4°C, time 5-10S Manual soldering 360±8°C, time 4-7S
Relative humidity	10~90% RH
Hot plug	Unavailable
Remote control terminal	Unavailable
Vibration	10-55Hz,10G,30Min,alongX,Y,Z
MTBF (MIL-HDBK-217F@25°C)	>300,000 Hours
Weight	6.6 g

Output specifications					
Item	Operating condition	Min	Typ	Max	Units
Voltage accuracy	Full input voltage range, Any load		±2.0	±3.0	%
Line regulation	Nominal Load			±0.5	%
Load regulation	Nominal input voltage, 20%~100% load			±1.0	%
Minimum load	Single Output	0			%
Turn-on delay time	Input 230VAC (full load)		500		mS
Power-off holding time	Input 230VAC (full load)		200		mS
Dynamic response	Overshoot range 25%~50%~25%	-5.0		+5.0	%
	Recovery time 50%~75%~50%			5.0	mS
Output overshoot	Full input voltage range		≤10%Vo		%
Drift coefficient		-	±0.03%	-	%/°C

Isolation specifications					
Item	Operating Conditions	Min	Typ	Max	Units
Isolation voltage	Input-Output - Test 1min, leakage current≤5mA	4000			VAC
Insulation resistance	Input-Output @ DC500V	100			MΩ

Input specifications					
Item	Operating condition	Min	Typ	Max	Units
Input voltage range	AC input	85	230	528	VAC
	DC input	127	325	745	VDC
Input frequency range		47	50	63	Hz
Input current	115VAC			0.30	A
	230VAC			0.20	
Surge current	115VAC			15	A
	230VAC			20	
No-load power consumption	Input 230VAC			0.4	W
	Output 528VAC			0.5	
External fuse	2.0A/500VAC, Slow fuse (necessary)				
Leakage current	0.25mA TYP / 230VAC/50HZ				

1. The product should be used within the specification range, or it will cause permanent damage to it;
2. The input terminal should connect to fuse;
3. If the product is worked under the minimum requested load, the product performance cannot be guaranteed to comply with all parameters in the datasheet;
4. If the product is not operated within the required load range, the product performance cannot be guaranteed to comply with all parameters in the datasheet;
5. Unless otherwise specified, parameters in this datasheet were measured under the conditions of Ta = 25°C, humidity <75% with
6. nominal input voltage and rated output load(pure resistance load);
7. All index testing methods in this datasheet are based on our company's corporate standards; The performance indexes of the product models listed in this manual are as above, but some indexes of non-standard model products will exceed the above-mentioned requirements, please directly contact our technician for specific information;
8. We can provide product customization service,
9. Specifications are subject to change without prior notice, please follow up with our website for newest manual.

**Example:**  
**5ACFE1W\_05S4**  
**5 = 5Watt; AC = AC-DC; F = Open Frame; E1 = Cost effective;**  
**W = Wide input; 05 = 5Vout; S = Single output; 4 = 4 kVAC isolation**

# SACFE1W\_4 series

5W - AC-DC converter

EMC specifications					
EMC	EMI	CE	CISPR22/EN55022	CLASS B (recommend circuit see Diagram 2)	
EMC	EMI	RE	CISPR22/EN55022	CLASS B (recommend circuit see Diagram 2)	
EMC	EMS	ESD	IEC/EN 61000-4-2	Contact ±6KV / Air ±8KV	perf.Criteria B (recommend circuit see Diagram 2)
EMC	EMS	RS	IEC/EN 61000-4-3	10V/m	perf. Criteria B (recommend circuit see Diagram 2)
EMC	EMS	EFT	IEC/EN 61000-4-4 IEC/EN 61000-4-4	±2KV ±4KV	perf. Criteria B (recommend circuit see Diagram 2) perf. Criteria B (recommend circuit see Diagram 2)
EMC	EMS	Surge	IEC/EN 61000-4-5	Line to line ±2KV / line to ground ±4KV (recommend circuit see Diagram 2)	
EMC	EMS	CS	IEC/EN61000-4-6	10 Vr.m.s	perf. Criteria B (recommend circuit see Diagram 2)

## Product Selection Guide

Approval	Model	Output Power (W)	Output Voltage Vo (V)	Output Current Iout (mA)	Max. Capacitive Load (uF)	Ripple & Noise 20MHz (Max)	Efficiency Full Load, 230VAC Typ. (%)
	SACFE1W_05S4	5	5	1000	700	80	74
	SACFE1W_12S4	5	12	416	500	100	78
	SACFE1W_15S4	5	15	333	400	120	79
	SACFE1W_24S4	5	24	208	300	150	80

Note:

- 1: The ripple test needs to be tested under the conditions of adding peripherals;
- 2: The minimum efficiency is defined as -2% of the typical value due to the instrumental error of the test equipment;
- 3: The typical value of output efficiency is based on the product aging for half an hour under full load;

## Product characteristic curve

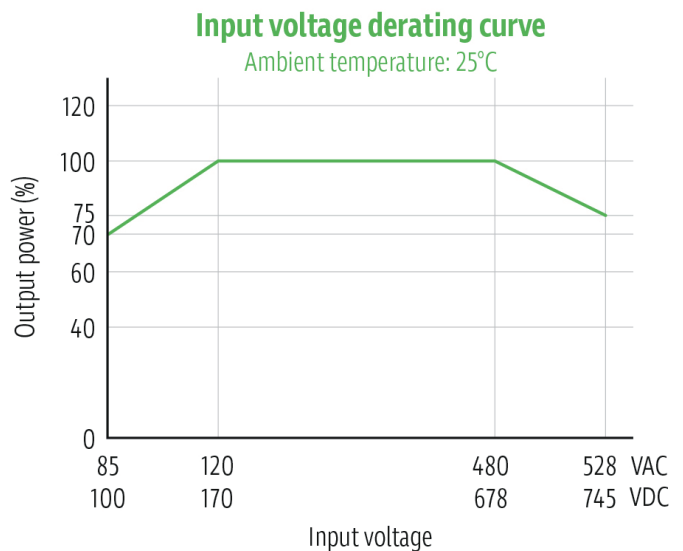
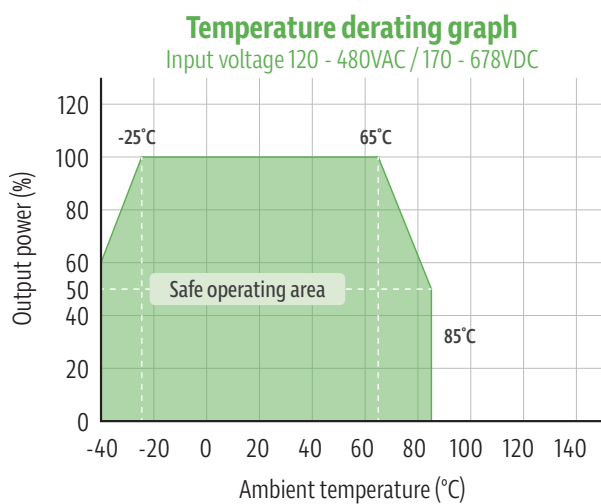

Note:

- 1: The input voltage is 85-120VAC/480-528VAC/100-1740VDC/678-745VDC, which needs to be derated based on the input voltage derating curve.
- 2: Our product is suitable to use under natural air cooling environment, if use it under closed condition, please contact with us.

## Dimensions and recommended layout

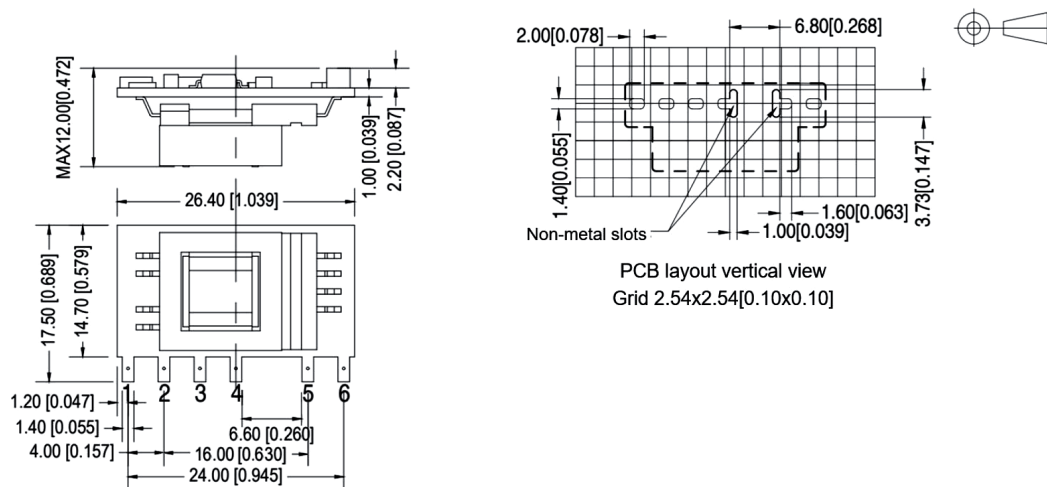

Unit: mm[inch]  
 General tolerance:  $\pm 1.00[\pm 0.039]$   
 Terminal section tolerance:  $\pm 0.25[\pm 0.010]$   
 The components layout is only for reference, any deviation from the actual unit should be accepted.

Pin	1	2	3	4	5	6
Single	AC(L)	AC(N)	+V(CAP)	-V(CAP)	-Vo	+Vo

## Typical application circuit

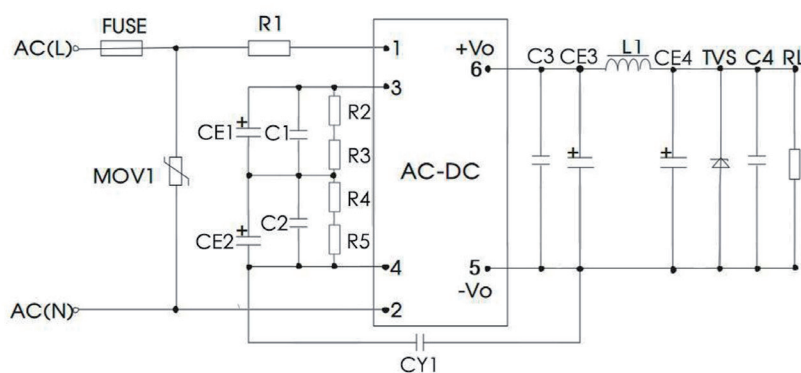

Diagram 1

Products Number	CE3 (Solid state capacitor must be connected)	L1 (required)	CE4 (Must be connected with electrolytic capacitor)	C1, C2	CY1 (required)	C3, C4	TVS1
5ACFE1W_0554	470uF/16V	2.2uF/5A	100uF/25V	0.1uF/630V	1nF/400VAC	0.1uF/50V	SMBJ7.0A
5ACFE1W_1254	220uF/16V	2.2uF/5A	100uF/25V	0.1uF/630V	1nF/400VAC	0.1uF/50V	SMBJ20A
5ACFE1W_2454	100uF/35V	2.2uF/5A	47uF/35V	0.1uF/630V	1nF/400VAC	0.1uF/50V	SMBJ30A

# 5ACFE1W\_4 series

5W - AC-DC converter

	CE1,CE2 (required)		R2,R3,R4,R5 (required)	
/	-25°C-85°C		-40°C-85°C	
85-528VAC	33uF/400V		1206/1MΩ	
165-528VAC	22uF/400V		1206/1MΩ	
85-305VAC	CE1: 10uF/450v CE2: Connecting wires		CE1: 22uF/450v CE2: Connecting wires	

- Note:
1. FUSE is a safety tube, the recommended specification is 1A/500VAC, slow break (must be connected)
  2. MOV is a varistor, 14D911K (required).
  3. R1 is metal sheath/cement resistance, 20Ω/3W (required);
  4. CE1, CE2: For AC input, it is a filter electrolytic capacitor; for DC input, it is a large filter capacitor in the EMC filter; it is recommended to use electrolytic capacitors with ripple current >200mA@100KHz, and it is recommended to use electrolytic capacitors with ESR≤100Ω at low temperatures..
  5. R2, R3, R4 and R5 are the voltage equalizing resistors of CE1 and CE2 and must be connected.
  6. C3 and C4 are ceramic capacitors to filter out high-frequency noise.
  7. CE3 and CE4 are output filter capacitors, which together with L1 form a Pi-type filter circuit. It is recommended to use high-frequency, low-resistance electrolytic capacitors (ESR≤1.1Ω at low temperature -40°C) or solid capacitors. Please refer to each manufacturer for capacity and rated ripple current. Technical specifications provided. The capacitor withstand voltage should be derated by at least 80%.

## EMC recommended circuit

Application Environment	Temperature Range	EMS Level	EMI Level
general indoor environment	-25°C-55°C	Level 3	CLASS B

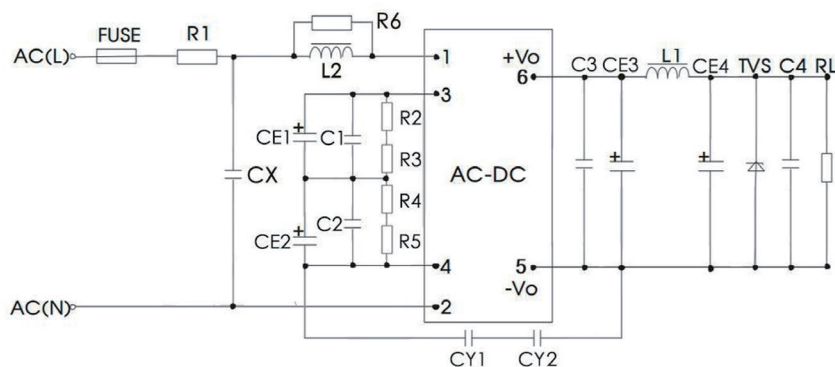

Diagram 2

Components	Recommended Value
R1 (wire-wound resistor, required)	12Ω/3W
R2 (Chip resistor)	Vout: 5V
	Vout: 12V
	Vout: 24V
L2	Vout: 5V
	Vout: 12V,24V
CX	0.1uF/480VAC
FUSE (Required)	1A/500V, Slow fuse

- Note:
1. In the home appliance application environment, the two Y capacitors on the original sides need to be connected externally at the same time (CY1, CY2, specification value is 2.2nF/400VAC), which can meet 60335 certification;
  2. According to certification requirements, the X capacitor needs to be connected in parallel with a bleeder resistor. The recommended value is 28MΩ. The actual selection needs to be based on certification standards.
  3. R1 is a plug-in resistor at the input end. This resistor needs to be a wire-wound resistor. Do not choose a chip resistor or a carbon film resistor.

Recommended circuits for general systems in indoor industrial environments

Application Environment	Temperature Range	EMS Level	EMI Level
indoor industry environment	-25°C-55°C	Level 4	CLASS B

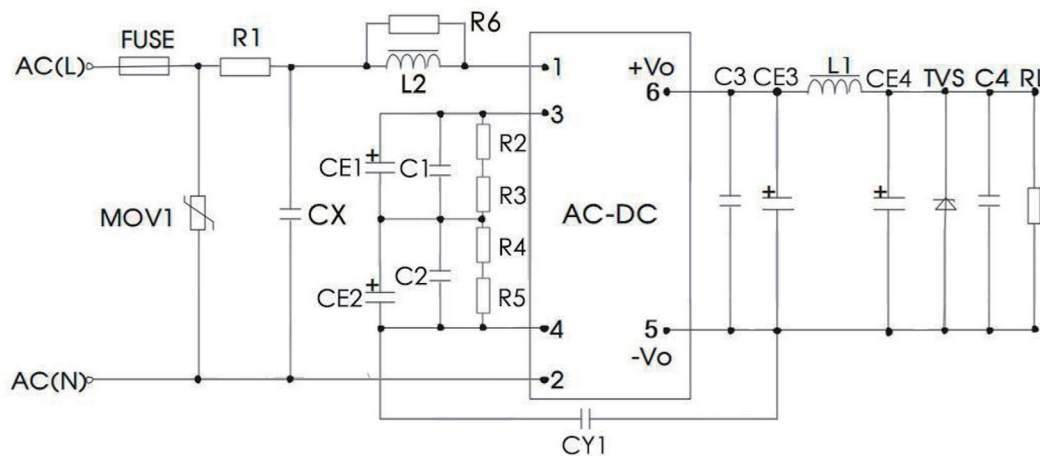

Diagram 3

Component Tag	Recommended Value
MOV1	14D911K
R1 (wire-wound resistor, required)	12Ω/3W
R2 (Chip resistor)	Vout: 5V
	Vout: 12V
	Vout: 24V
L2	Vout: 5V
	Vout: 12V,24V
CX	0.1uF/480VAC
FUSE (Required)	2A/500V, Slow fuse

Note:

1. According to certification requirements, the X capacitor needs to be connected in parallel with a bleeder resistor. The recommended value is <math>\leq 3.8M\Omega</math>. The actual selection needs to be based on certification standards;
2. R1 is a plug-in resistor at the input end. This resistor needs to be a wire-wound resistor. Do not choose a chip resistor or a carbon film resistor.

Recommended circuit for general system in general outdoor environment

Application Environment	Temperature Range	EMS Level	EMI Level
general outdoor environment	-40°C-85°C	Level 4	CLASS A

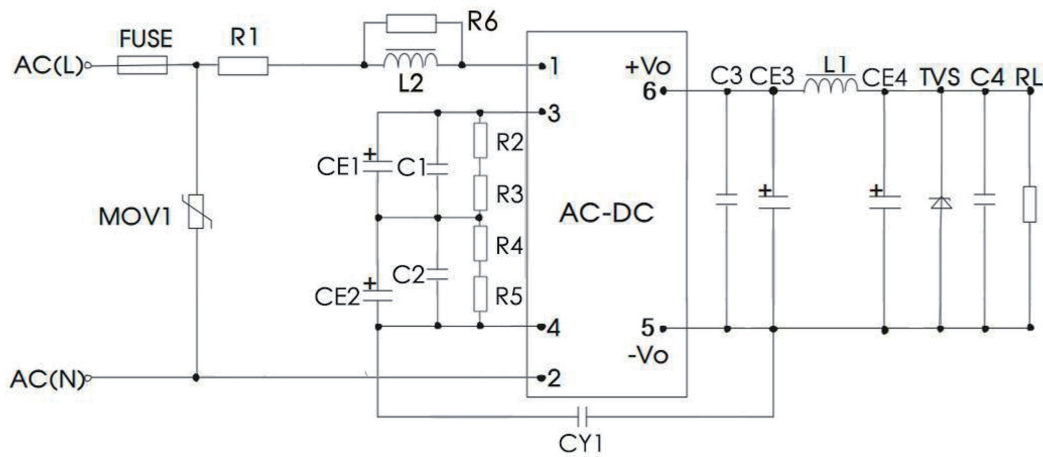

Diagram 4

Component Tag	Recommended Value	
MOV1	14D911K	
R1 (wire-wound resistor, required)	12Ω/3W	
R2 (Chip resistor)	Vout: 5V	1206/20K
	Vout: 12V	1206/2K
	Vout: 24V	1206/15K
L2	Vout: 5V	1.2mH/Max:2.5Ω/Min:0.2A
	Vout: 12V,24V	4.7mH/Max:15Ω/Min:0.2A
FUSE (require)	2A/500V, Slow fuse	

Note: R1 is a plug-in resistor at the input end. This resistor needs to be a wire-wound resistor. Do not choose a chip resistor or a carbon film resistor.

Recommended circuit for general system in outdoor industrial environment

Application Environment	Temperature Range	EMS Level	EMI Level
outdoor industrial environment	-40°C-85°C	Level 4	CLASS A

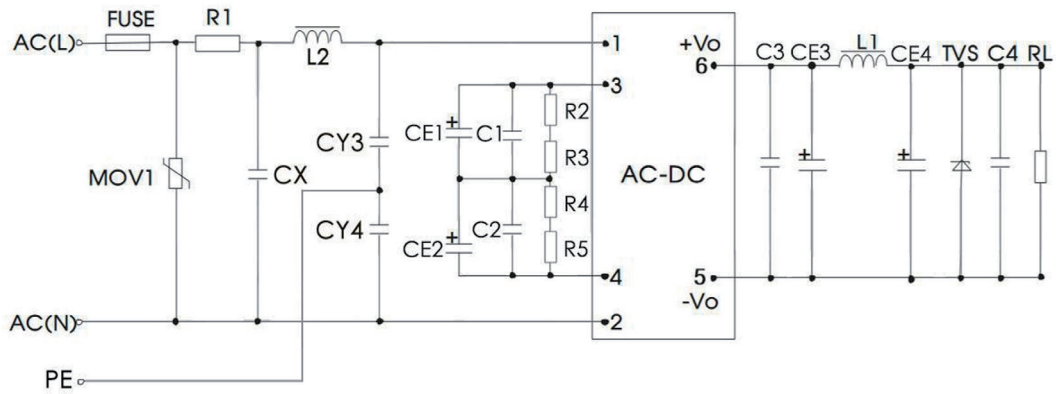

Diagram 5

Component Tag	Recommended Value
MOV1	14D911K
R1 (wire-wound resistor, required)	12Ω/3W
L2	Vout: 5V
	Vout: 12V,24V
CX	0.1uF/480VAC
FUSE (required)	2A/500V, Slow fuse
CY3,CY4	1nF/400VAC

Note: R1 is a plug-in resistor at the input end. This resistor needs to be a wire-wound resistor. Do not choose a chip resistor or a carbon film resistor.

Recommended circuit for general system in strong lightning surge environment

Application Environment	Temperature Range	EMS Level	EMI Level
strong lightning surge environment	-40°C-85°C	Level 4	CLASS A

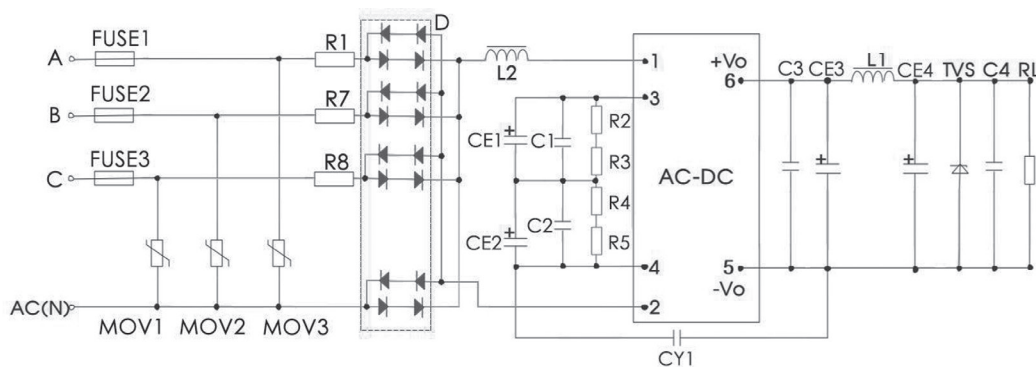

Diagram 6.1

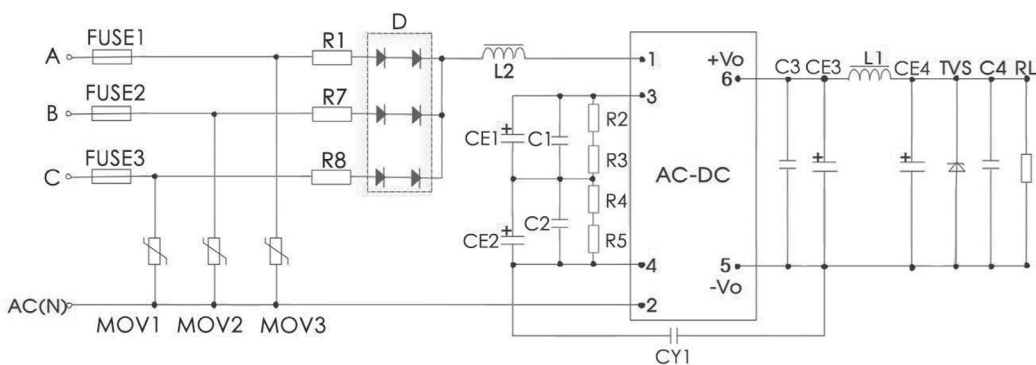

Diagram 6.2

Recommended peripheral circuit diagram for high requirements of 4kV differential mode surge - half-wave rectification

Component Tag	Recommended Value
MOV1,MOV2,MOV3	14D911K
R1,R7,R8 (wire-wound resistor, required)	12Ω/5W
L2	Vout: 5V 1.2mH/Max:2.5Ω/Min:0.2A
	Vout: 12V,24V 4.7mH/Max:15Ω/Min:0.2A
CX	0.1uF/480VAC
D	2A/1000V
FUSE1,FUSE2,FUSE3 (required)	2A/500V,slow fuse

Note: R1 is a plug-in resistor at the input end. This resistor needs to be a wire-wound resistor. Do not choose a chip resistor or a carbon film resistor.