



LMT78_1.0R1 series

Wide input, non-isolated & regulated, single output, SMD package

Switching Regulator

- ⊕ 10PIN SMD package
- ⊕ UL94V-0 package material
- ⊕ Operating temperature: -40°C to +85°C
- ⊕ Efficiency up to 92%
- ⊕ Non isolated
- ⊕ No need for heatsinks
- ⊕ Short circuit protection

The Introducing our advanced LMT78_1.0R series with a 10PIN SMD package, engineered for superior performance and reliability. Constructed with UL94V-0 package material, it ensures high safety standards and flame retardancy. This package operates efficiently within a temperature range of -40°C to +85°C, making it suitable for various environmental conditions.

With an impressive efficiency of up to 95%, this non-isolated package delivers optimal energy utilization without the need for additional heatsinks. Its design includes built-in short circuit protection, providing an extra layer of safety and durability for your applications.



Common specifications	
Cooling:	Free air convection @(20 LFM)
Short circuit protection mode:	Hiccup mode
Short circuit protection:	Continuous, automatic recovery
Operating temperature range:	-40°C ~ +85°C (with derating)
Storage temperature range:	-55°C ~ +125°C
Conducted Emission	EN55022 Class A
Radiated Emission	EN55022 Class A
Reflow Soldering Temperature:	Peak temp. ≤ 245°C, maximum duration time ≤ 60s at 217°C. For actual application, please refer to IPC/JEDEC J-STD-020D.1
Storage humidity range:	95% (max.)
Case material:	Plastic [UL94-V0]
MTBF (MIL-HDBK-217F, +25°C):	> 5000 x 103 hours (ground benign)
Package weight:	1.8g
Dimensions:	15.24 x 8.00 x 8.50mm
MSL (Moisture sensitivity level):	J-STD-020D standard - Level 2

Output specifications					
Item	Test conditions	Min	Typ	Max	Units
Output voltage accuracy	5V			±2	%
	12V			±3	%
Output current	5V		500		mA
	12V		1000		mA
Line regulation	@ at Full Load			±0.4	%
Load regulation	@10% to 100% load			±0.6	%
Ripple + Noise*	20MHz bandwidth			75	mVp-p
Output Voltage Adjustability (Trim)				±10	%
Transient response deviation	Nominal input voltage, 25% load step change		50	200	mV
Transient recovery time	Nominal input voltage, 25% load step change		0.2	1	ms
Vadj	input voltage range		±10		%Vo
Switching frequency			440		kHz

* Ripple and noise tested with "parallel cable" method, please refer to DC-DC converter Application Notes for specific operation methods.

Example:

LMT78_05-1.0R1

LM = Series; T = SMT case; 05 = 5Vout; 1.0 = 1.0A; R1 = Revised series

Note:

1. All specifications measured at Ta = 25°C, humidity <75%, nominal input voltage and rated output load unless otherwise specified.
2. In this datasheet, all the test methods of indications are based on corporate standards.

Input specifications					
Item	Test conditions	Min	Typ	Max	Units
No load input current			3		mA
Reverse polarity input	Forbidden				
Input filter	Capacitor				
Remote ON	3.2 ~ 5.5VDC or open circuit				
Remote OFF	0 ~ 0.8VDC or short circuit pin 10 and 3/7				
OFF Idle Current	0.2mA typ.				

LMT78_1.0R1 series

Wide input, non-isolated & regulated, single output, SMD package

EMC specifications				
EMI	CE	CISPR32/EN55022	CLASS B	(see EMC recommended circuit, ②)
EMI	RE	CISPR32/EN55022	CLASS B	(see EMC recommended circuit, ②)
EMS	ESD	IEC/EN61000-4-2	Contact ±4KV	perf. Criteria B
EMS	RS	IEC/EN61000-4-3	10V/m	perf. Criteria A
EMS	EFT	IEC/EN61000-4-4	±2kV	perf. Criteria B (see EMC recommended circuit, ①)
EMS	Surge	IEC/EN61000-4-5	line to line ±1KV	perf. Criteria B (see EMC recommended circuit, ①)
EMS	CS	IEC/EN61000-4-6	3 Vr.m.s	perf. Criteria A

Product Selection Guide

Part Number	Input Voltage [VDC]		Output Voltage [VDC]	Output Current [mA, Max]	Capacitive load [μF, max]	Efficiency [Vin. max]
	Nominal	Range				
LMT78_03-1.0R1	24	6.5-36	3.3	1000	680	80
LMT78_05-1.0R1	24	8-36	5	1000	680	85
LMT78_12-1.0R1	24	16-36	12	800	680	92
LMT78_15-1.0R1	24	20-36	15	800	680	92

Note:

For input voltage higher than 30VDC, a 22μF/50V input capacitor is required.

LMT78_15-1.0R1 is only available in C-package style. All other variations can be produced in standard or C-package style. Please use /C for C-package: LMT78_03-1.0R1/C

Typical characteristics

Temperature derating graph

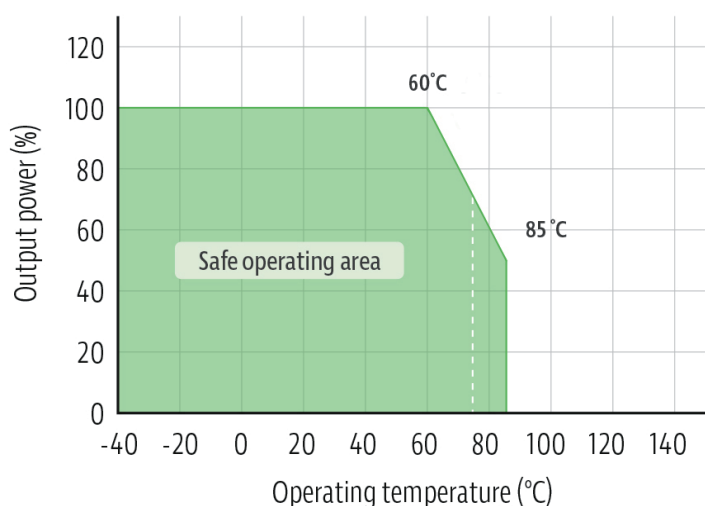

LMT78_1.0R1 series

Wide input, non-isolated & regulated, single output, SMD package

Application of Vadj and calculation of Vadj resistance

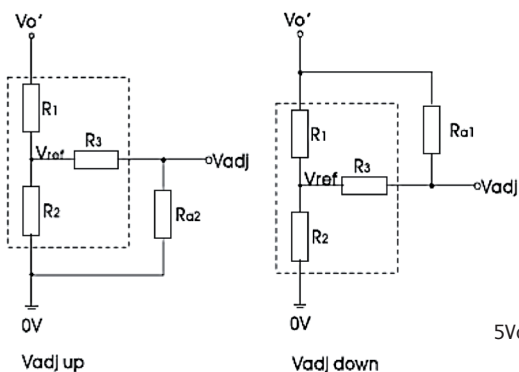

Calculation formula of Vadj resistance:

$$\text{up: } R_{a2} = \frac{\alpha R_2}{R_2 - \alpha} - R_3 \quad \alpha = \frac{V_{ref}}{V_{o'} - V_{ref}} \cdot R_1$$

$$\text{down: } R_{a1} = \frac{\alpha R_1}{R_1 - \alpha} - R_3 \quad \alpha = \frac{V_{o'} - V_{ref}}{V_{ref}} \cdot R_2$$

Ra1, Ra2 is Vadj resistance, a is a self-defined parameter, with no real meaning. Vo' for the actual needs of the up or down regulated voltage

	R1/KΩ	R2/KΩ	R3/KΩ	Vref/V
5Vout	43	8.06	33	0.8
12Vout	200	14.3	33	0.8

Typical application circuit

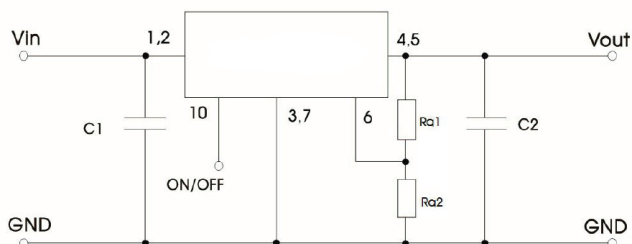

Note:

- C1 and C2 are required and should be connected close to the pin terminal of the module.
- The capacitance of C1 and C2 refer to table 1, it can be increased properly if required, and tantalum or low ESR electrolytic capacitors may also suffice.
- Cannot be used in parallel for output and hot swap.
To reduce the output ripple furtherly, it is suggested to connect a "LC" filter at the output terminal, and recommended value of L is 10μH-47μH.

Part number Vin (24VDC)	C1	Single Vout	C2
LMT78_05-1.0R1	10μF/50V	5VDC	22μF/16V
LMT78_12-1.0R1	10μF/50V	12VDC	22μF/25V

Table 1

EMC (CLASS B) compliance circuit

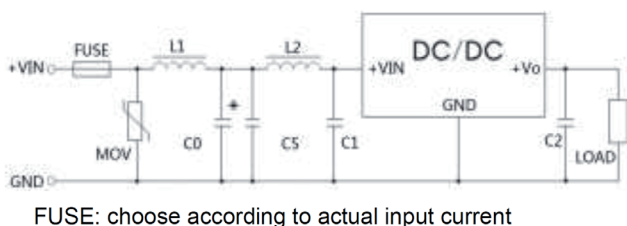

FUSE: choose according to actual input current

Component	Value	Component	Value
MOV	S20K30	C0	680μF/50V
L1	82μH	C1,C2	refer to Flg.1
L2	68μH	C5	4.7μF/50V

Fig. 2

LMT78_1.0R1 series

Wide input, non-isolated & regulated, single output, SMD package

Mechanical dimensions - Standard package

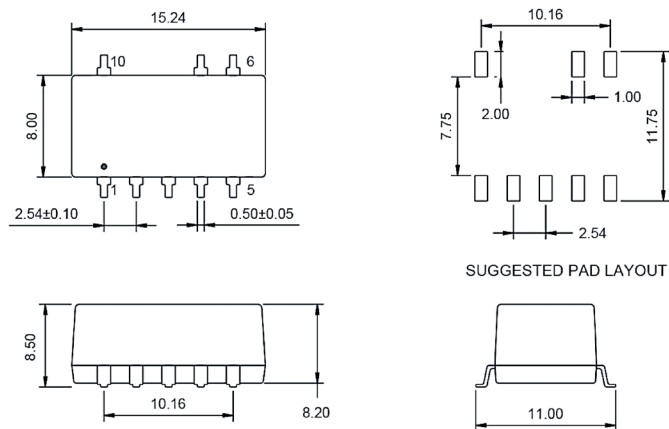

PIN Assignment

PIN	1.2	3.7	4.5	6	10
FUNCTION	+Vin	GND	+Vout	V adj	Remote On/Off

Note:

Unit: mm[inch]

Pin selection tolerances: ±0.10mm [±0.004inch]

General tolerances: ±0.25mm [±0.010inch]

Mechanical dimensions - C-package

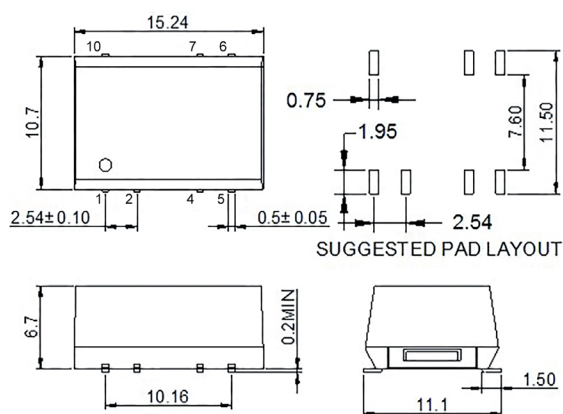

PIN _o	1	2	4	5	6	7	10
FUNCTION _o	+Vin	+Vin	+Vout1	+Vout1	V <u>adj</u>	GND	Remote On/Off

LMT78_1.0R1 series

Wide input, non-isolated & regulated, single output, SMD package

IR Reflow peak temperature: 240degC +/-5degC

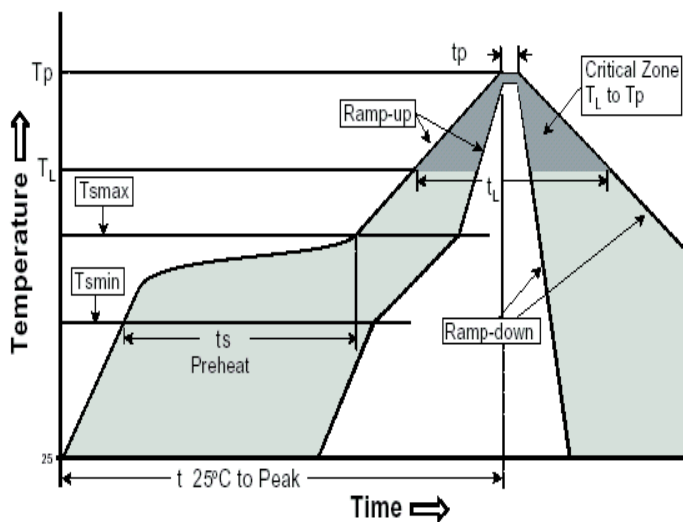

Profile Feature	Pb-Free Assembly
Average Ramp-Up Rate (T_{smax} to T_p)	3°C /second max.
Preheat	
-Temperature Min (T_{smin})	150°C
-Temperature Max (T_{smax})	200°C
-Time (T_{smin} to T_{smax})	60-180 seconds
Time maintained above:	
-Temperature (T_L)	217°C
-Time (t_L)	60-150 seconds
Peak/Classification Temperature (T_p)	240±5°C
Time within 5°C of actual Peak Temperature (t_p)	20-40 seconds
Ramp-Down Rate	6°C/seconds max
Time 25°C to Peak Temperature	6 minutes max.