

Silicon Standard Recovery Diode

$V_{RRM} = 400\text{ V} - 1800\text{ V}$

$I_F = 165\text{ A}$

Features

- High Surge Capability
- Types up to 1800 V V_{RRM}
- Equivalent to SKN130 Series
- Not ESD Sensitive

DO-8 Package



Maximum ratings, at $T_j = 25\text{ }^\circ\text{C}$, unless otherwise specified (GKR has leads reversed)

Parameter	Symbol	Conditions	GKN130/04	GKN130/08	GKN130/12	GKN130/14	GKN130/16	GKN130/18	Unit
Repetitive peak reverse voltage	V_{RRM}		400	800	1200	1400	1600	1800	V
DC blocking voltage	V_{DC}		400	800	1200	1400	1600	1800	V
Continuous forward current	I_F	$T_C \leq 100\text{ }^\circ\text{C}$	165	165	165	165	165	165	A
Surge non-repetitive forward current, Half Sine Wave	$I_{F,SM}$	$T_C = 25\text{ }^\circ\text{C}$, $t_p = 10\text{ ms}$	2500	2500	2500	2500	2500	2500	A
Operating temperature	T_j		-55 to 150	-55 to 150	-55 to 150	-55 to 150	-55 to 150	-55 to 150	$^\circ\text{C}$
Storage temperature	T_{stg}		-55 to 150	-55 to 150	-55 to 150	-55 to 150	-55 to 150	-55 to 150	$^\circ\text{C}$

Electrical characteristics, at $T_j = 25\text{ }^\circ\text{C}$, unless otherwise specified

Parameter	Symbol	Conditions	GKN130/04	GKN130/08	GKN130/12	GKN130/14	GKN130/16	GKN130/18	Unit
Diode forward voltage	V_F	$I_F = 60\text{ A}$, $T_j = 25\text{ }^\circ\text{C}$	1.5	1.5	1.5	1.5	1.5	1.5	V
Reverse current	I_R	$V_R = V_{RRM}$, $T_j = 180\text{ }^\circ\text{C}$	22	22	22	22	22	22	mA

Thermal characteristics

Parameter	Symbol	Conditions	GKN130/04	GKN130/08	GKN130/12	GKN130/14	GKN130/16	GKN130/18	Unit
Thermal resistance, junction - case	R_{thJC}		0.35	0.35	0.35	0.35	0.35	0.35	K/W

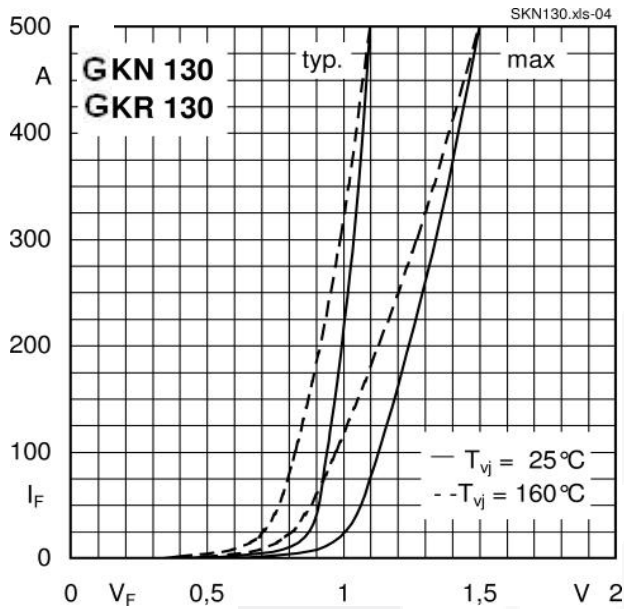

Fig 1: Forward Characteristics

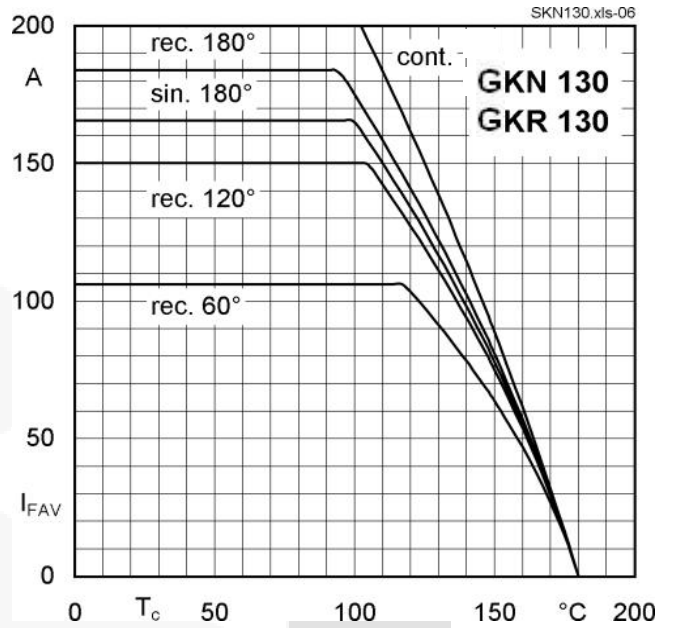

Fig 2: Forward Current vs Case Temp

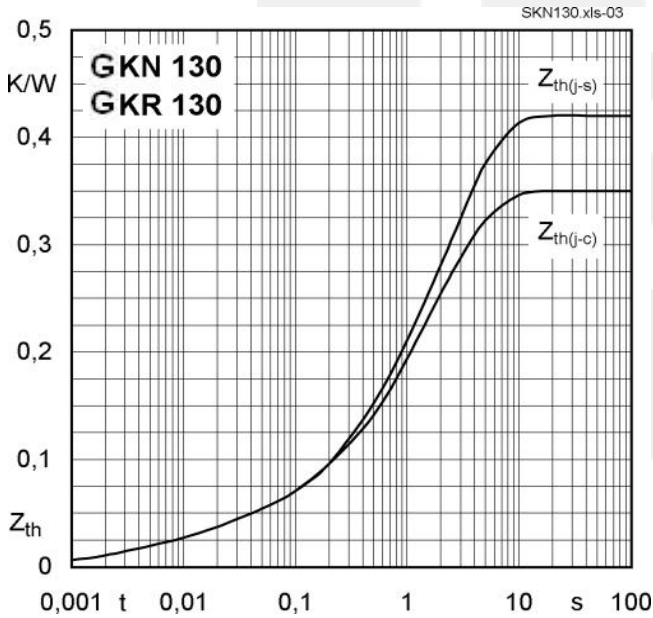

Fig 3: Transient Thermal Impedance vs Time

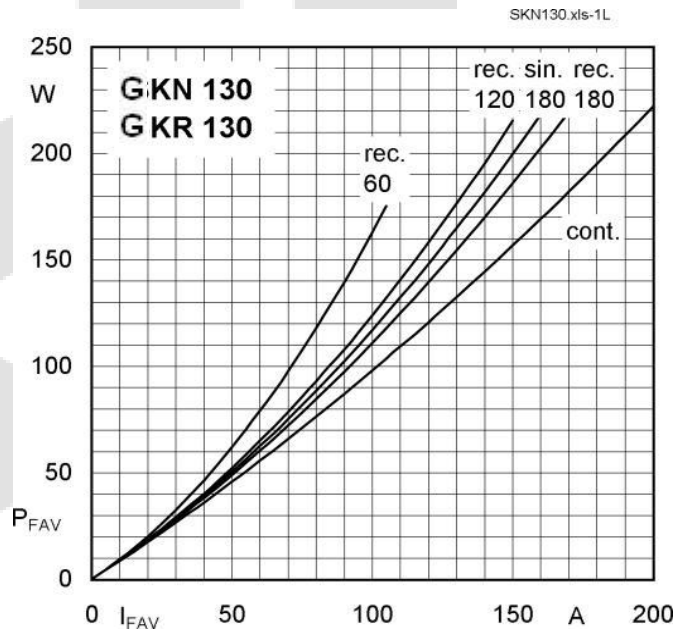
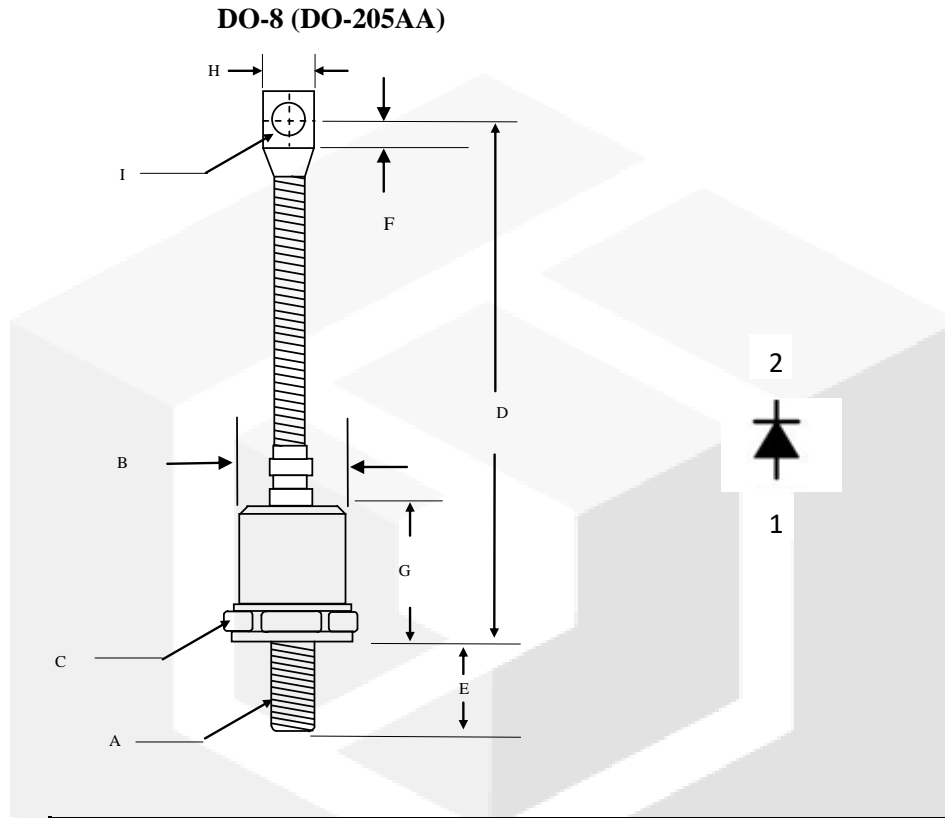

Fig 4: Power Dissipation vs Forward Current

Package dimensions and terminal configuration

Product is marked with part number and terminal configuration.



	Inches		Millimeters	
	Min	Max	Min	Max
A	3/8-24 UNF			
B	----	φ0.930	----	φ23.5
C	1.050	1.060	26.67	26.92
D	4.300	4.700	109.22	119.38
E	----	0.690	----	17.00
F	0.260	----	6.50	----
G	----	0.940	----	24.00
H	----	0.600	----	15.23
I	0.276	0.286	7.010	7.260