

Silicon Standard Recovery Diode

$V_{RRM} = 400\text{ V} - 1800\text{ V}$

$I_F = 320\text{ A}$

Features

- High Surge Capability
- Types from 400 V to 1800 V V_{RRM}
- Equivalent to SKN240 Series
- Not ESD Sensitive

DO-9 Package



Maximum ratings, at $T_j = 25\text{ }^\circ\text{C}$, unless otherwise specified (GKR has leads reversed)

Parameter	Symbol	Conditions	GKN240/04	GKN240/08	GKN240/12	GKN240/14	GKN240/16	GKN240/18	Unit
Repetitive peak reverse voltage	V_{RRM}		400	800	1200	1400	1600	1800	V
DC blocking voltage	V_{DC}		400	800	1200	1400	1600	1800	V
Continuous forward current	I_F	$T_C \leq 100\text{ }^\circ\text{C}$	320	320	320	320	320	320	A
Surge non-repetitive forward current, Half Sine Wave	$I_{F,SM}$	$T_C = 25\text{ }^\circ\text{C}$, $t_p = 10\text{ ms}$	6000	6000	6000	6000	6000	6000	A
Operating temperature	T_j		-55 to 150	-55 to 150	-55 to 150	-55 to 150	-55 to 150	-55 to 150	$^\circ\text{C}$
Storage temperature	T_{stg}		-55 to 150	-55 to 150	-55 to 150	-55 to 150	-55 to 150	-55 to 150	$^\circ\text{C}$

Electrical characteristics, at $T_j = 25\text{ }^\circ\text{C}$, unless otherwise specified

Parameter	Symbol	Conditions	GKN240/04	GKN240/08	GKN240/12	GKN240/14	GKN240/16	GKN240/18	Unit
Diode forward voltage	V_F	$I_F = 60\text{ A}$, $T_j = 25\text{ }^\circ\text{C}$	1.4	1.4	1.4	1.4	1.4	1.4	V
Reverse current	I_R	$V_R = V_{RRM}$, $T_j = 180\text{ }^\circ\text{C}$	60	60	60	60	60	60	mA

Thermal characteristics

Parameter	Symbol	Conditions	GKN240/04	GKN240/08	GKN240/12	GKN240/14	GKN240/16	GKN240/18	Unit
Thermal resistance, junction - case	R_{thJC}		0.20	0.20	0.20	0.20	0.20	0.20	K/W

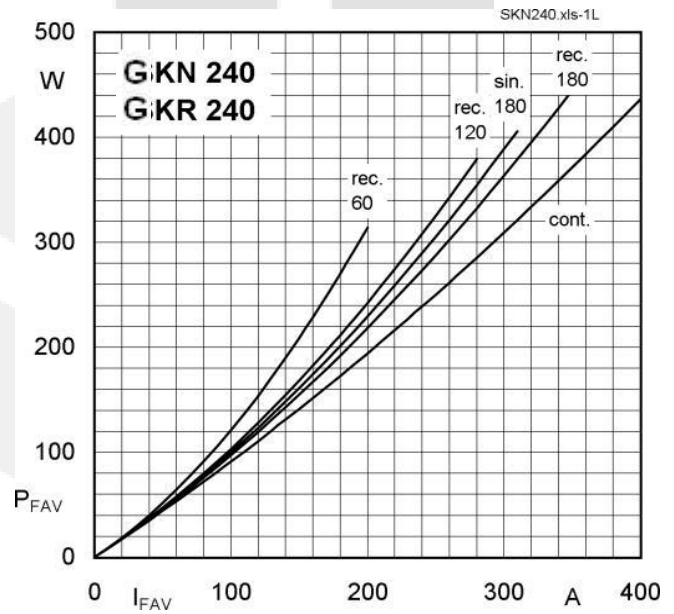
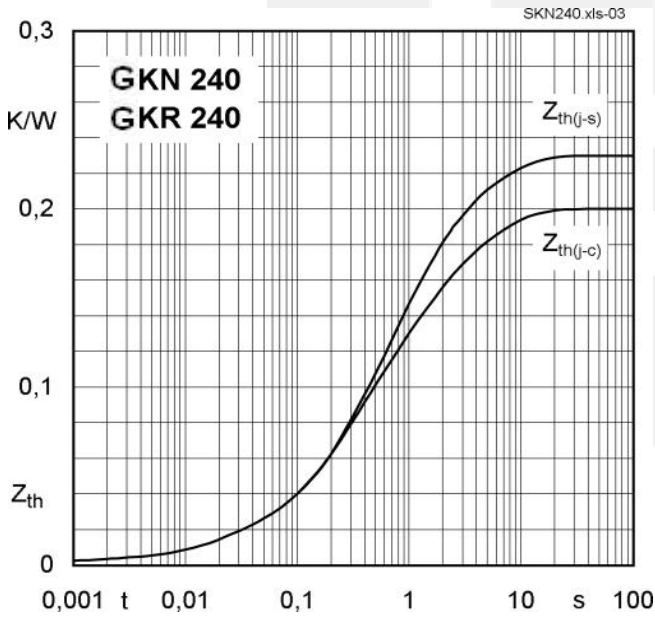
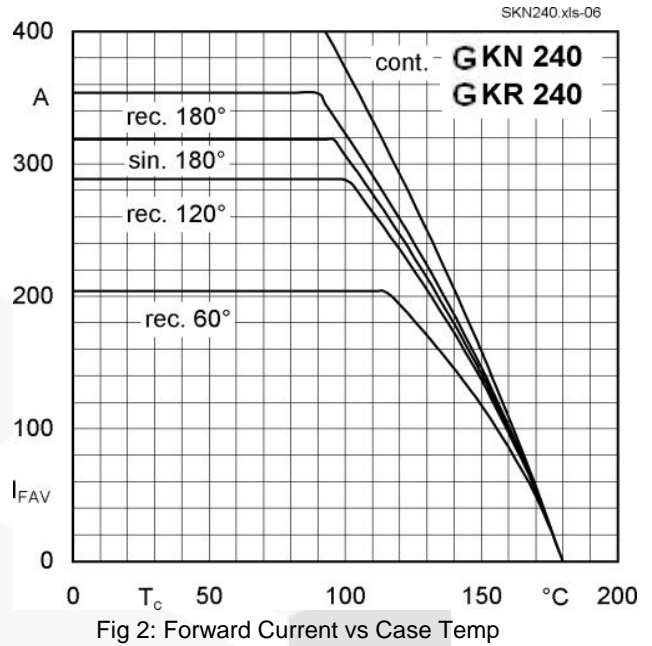
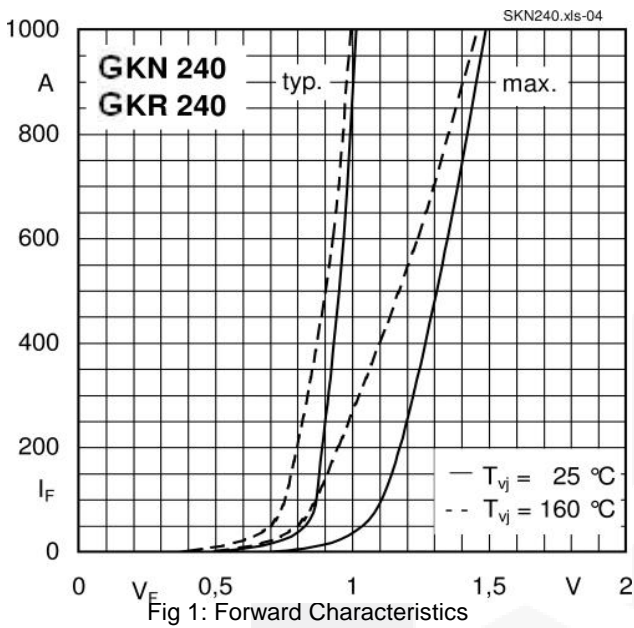

Package dimensions and terminal configuration

Product is marked with part number and terminal configuration.

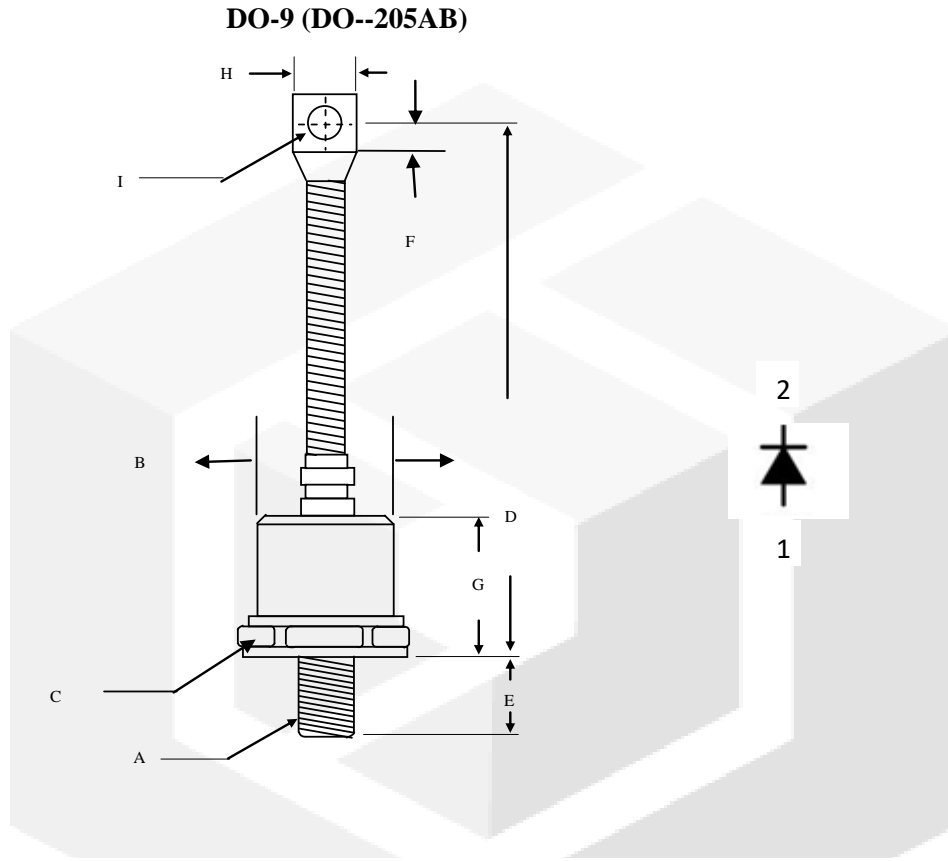

	Inches		Millimeters	
	Min	Max	Min	Max
A	3/4 - 16 UNF			
B	-----	1.10	-----	27.94
C	1.24	1.25	31.5	31.90
D	-----	7.48	-----	190.0
E	0.78	0.828	19.60	21.03
F	0.470	0.530	11.94	13.46
G	-----	1.122	-----	28.5
H	-----	0.787	-----	20.0
I	0.330	0.350	8.38	8.89