

**GT24C512A**

---



**Advanced**

**GT24C512A**

**Automotive (A2)**

**2-WIRE 512K Bits**

**Serial EEPROM**



# GT24C512A

## Table of Contents

<b>1. Features</b>	3
<b>2. General Description</b>	3
<b>3. Functional Block Diagram</b>	4
<b>4. Pin Configuration</b>	5
4.1 8-Pin SOIC and TSSOP	5
4.2 8-Lead UDFN	5
4.3 Pin Definition	5
4.4 Pin Descriptions	5
<b>5. Device Operation</b>	6
5.1 2-WIRE Bus	6
5.2 The Bus Protocol	6
5.3 Start Condition	6
5.4 Stop Condition	6
5.5 Acknowledge	6
5.6 Reset	6
5.7 Standby Mode	6
5.8 Device Addressing	6
5.9 Write Operation	7
5.10 Read Operation	8
5.11 Diagrams	9
5.12 Timing Diagrams	12
<b>6. Electrical Characteristics</b>	13
6.1 Absolute Maximum Ratings	13
6.2 Operating Range	13
6.3 Reliability	13
6.4 Capacitance	13
6.5 DC Electrical Characteristic	14
6.6 AC Electrical Characteristic	15
<b>7. Ordering Information</b>	16
<b>8. Top Markings</b>	17
8.1 SOIC Package	17
8.2 TSSOP Package	17
8.3 UDFN Package	17
<b>9. Package Information</b>	18
9.1 SOIC	18
9.2 TSSOP	19
9.3 UDFN	20
<b>10. Revision History</b>	21



# GT24C512A

---

## 1. Features

- Two-Wire Serial Interface, I<sup>2</sup>C™ Compatible
  - Bi-directional data transfer protocol
- Wide-voltage Operation
  - V<sub>CC</sub> = 2.5V to 5.5V
- Speed: 1 MHz (2.5V~5.5V)
- Standby current (max.): 3 μA, 5.5V
- Operating current (max.): 1 mA, 5.5V
- Hardware Data Protection
  - Write Protect Pin
- Sequential & Random Read Features
- Memory organization: 65,536 x 8 bits
- Page Size: 128 bytes
- Page write mode
  - Up to 128 bytes per page write
  - Offer an 128-bytes additional Identification page
- Self timed write cycle with auto clear: 5ms (max.)
- Filtered inputs for noise suppression
- High-reliability
  - Endurance: 1 million cycles
  - Data retention: 100 years
- Compliant with automotive standard AEC-Q100 grade 2
- Packages: SOIC, TSSOP, UDFN
- Lead-free, RoHS, Halogen free, Green

## 2. General Description

The GT24C512A are EEPROM devices that use the standard 2-wire interface for communications. The GT24C512A contains a memory array of 512K-bits (65,536x8), which is organized in 128-byte per page.

The EEPROM can operate in a wide voltage range from 2.5V to 5.5V which fits most application. This product can provide a low-power 2-wire EEPROM solution. The device is offered in Lead-free, RoHS, halogen free or Green. The available package types are 8-pin SOIC, TSSOP and UDFN.

The GT24C512A is compatible with the standard 2-wire bus protocol. If in case the bus is not responded, a new sent Op-code command will reset the bus and the device will respond correctly. The simple bus consists of the Serial Clock wire (SCL) and the Serial Data wire (SDA). Utilizing such bus protocol, a Master device, such as a microcontroller, can usually control one or more Slave devices, alike this GT24C512A. The bit stream over the SDA line includes a series of bytes, which identifies a particular Slave device, an instruction, an address within that Slave device, and a series of data, if appropriate. The GT24C512A also has a Write Protect pin (WP) to allow blocking any write operations over specified memory area.

The GT24C512A also offers an additional page, named the Identification Page (128 bytes) which can be written and (later) permanently locked in Read-only mode. This Identification Page offers flexibility in the application board production line, as the Identification Page can be used to store unique identification parameters and/or parameters specific to the production line.

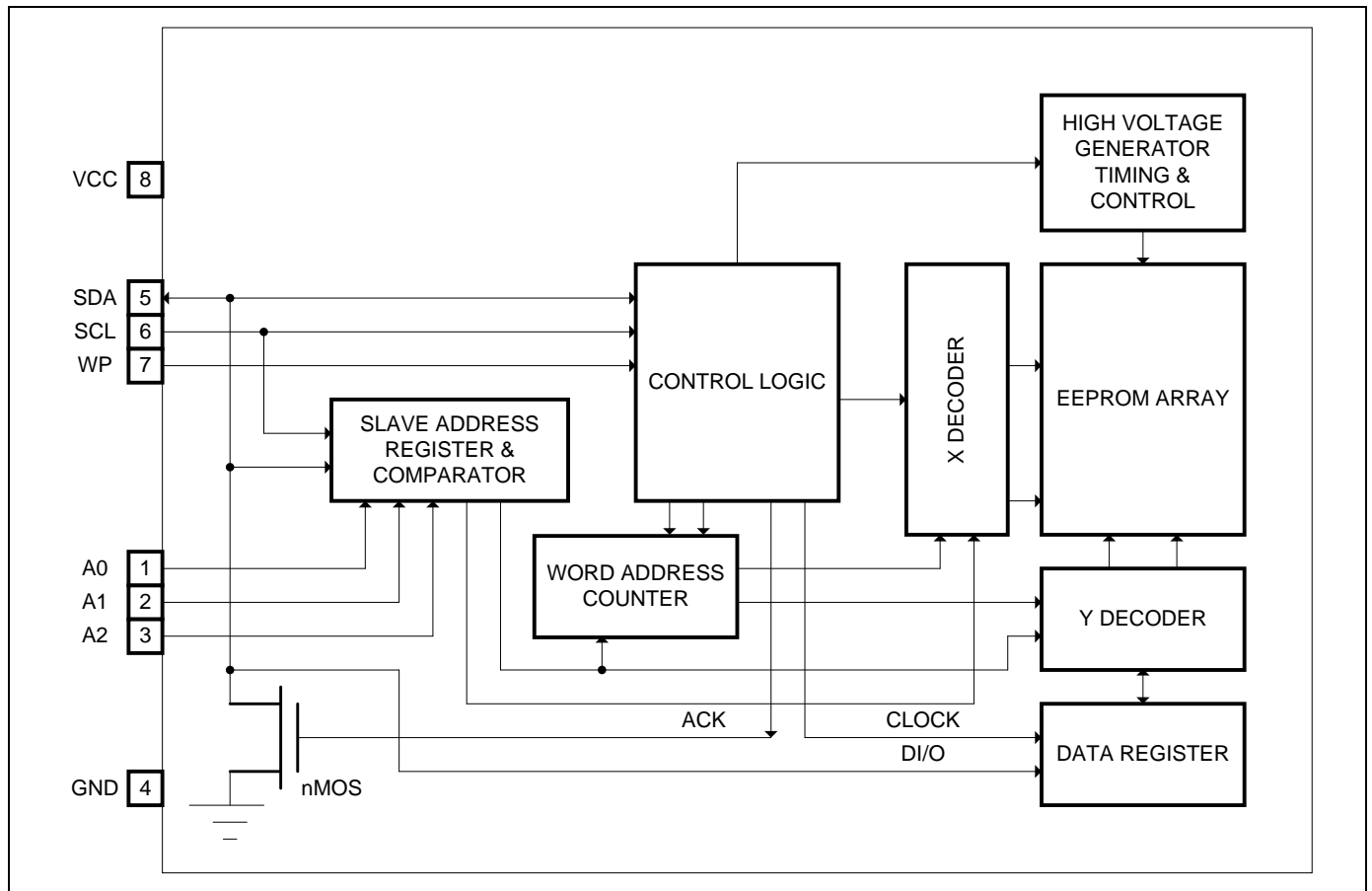
Under no circumstance, the device will be hung up. In order to refrain the state machine entering into a wrong state during power-up sequence or a power toggle off-on condition, a power on reset circuit is embedded. During power-up, the device does not respond to any instructions until the supply voltage (V<sub>CC</sub>) has reached an acceptable stable level above the reset threshold voltage. Once V<sub>CC</sub> passes the power on reset threshold, the device is reset and enters into the Standby mode. This would also avoid any inadvertent Write operations during power-up stage. During power-down process, the device will enter into standby mode, once V<sub>CC</sub> drops below the power on reset threshold voltage. In addition, the device will be in standby mode after receiving the Stop command, provided that no internal write operation is in progress. Nevertheless, it is illegal to send a command unless the V<sub>CC</sub> is within its



# GT24C512A

operating level.

## 3. Functional Block Diagram

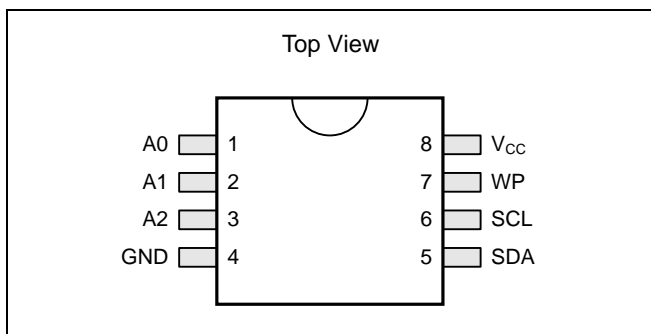




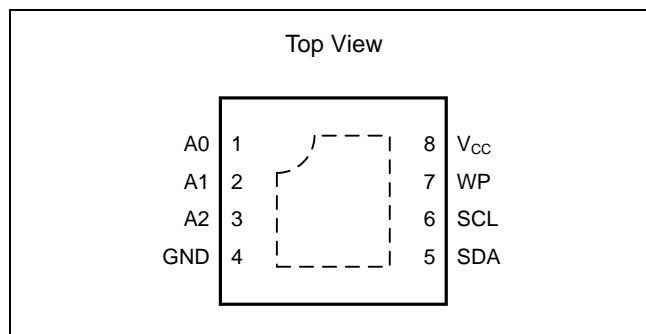
# GT24C512A

## 4. Pin Configuration

### 4.1 8-Pin SOIC and TSSOP



### 4.2 8-Lead UDFN



### 4.3 Pin Definition

Pin No.	Pin Name	I/O	Definition
1	A0	I	Device Address Input
2	A1	I	Device Address Input
3	A2	I	Device Address Input
4	GND	-	Ground
5	SDA	I/O	Serial Address and Data input and Data out put
6	SCL	I	Serial Clock Input
7	WP	I	Write Protect Input
8	V <sub>cc</sub>	-	Power Supply

### 4.4 Pin Descriptions

#### SCL

This input clock pin is used to synchronize the data transfer to and from the device.

#### SDA

The SDA is a bi-directional pin used to transfer addresses and data into and out of the device. The SDA pin is an open drain output and can be wired with other open drain or open collector outputs. However, the SDA pin requires a pull-up resistor connected to the power supply.

#### A0, A1, A2

The A0, A1 and A2 are the device address inputs.

Typically, the A0, A1, and A2 pins are for hardware addressing and a total of 8 devices can be connected on a

single bus system. When A0, A1, and A2 are left floating, the inputs are defaulted to zero.

#### WP

WP is the Write Protect pin. While the WP pin is connected to the power supply of GT24C512A, the entire array becomes Write Protected (i.e. the device becomes Read only). When WP is tied to Ground or left floating, the normal write operations are allowed.

#### V<sub>cc</sub>

Supply voltage

#### GND

Ground of supply voltage



# GT24C512A

---

## 5. Device Operation

The GT24C512A serial interface supports communications using standard 2-wire bus protocol, such as I<sup>2</sup>C.

### 5.1 2-WIRE Bus

The two-wire bus is defined as Serial Data (SDA), and Serial Clock (SCL). The protocol defines any device that sends data onto the SDA bus as a transmitter, and the receiving devices as receivers. The bus is controlled by Master device that generates the SCL, controls the bus access, and generates the Start and Stop conditions. The GT24C512A is the Slave device.

### 5.2 The Bus Protocol

Data transfer may be initiated only when the bus is not busy. During a data transfer, the SDA line must remain stable whenever the SCL line is high. Any changes in the SDA line while the SCL line is high will be interpreted as a Start or Stop condition.

The state of the SDA line represents valid data after a Start condition. The SDA line must be stable for the duration of the High period of the clock signal. The data on the SDA line may be changed during the Low period of the clock signal. There is one clock pulse per bit of data. Each data transfer is initiated with a Start condition and terminated by a Stop condition.

### 5.3 Start Condition

The Start condition precedes all commands to the device and is defined as a High to Low transition of SDA when SCL is High. The EEPROM monitors the SDA and SCL lines and will not respond until the Start condition is met.

### 5.4 Stop Condition

The Stop condition is defined as a Low to High transition of SDA when SCL is High. All operations must end with a Stop condition.

### 5.5 Acknowledge

After a successful data transfer, each receiving device is required to generate an ACK. The Acknowledging device pulls down the SDA line.

### 5.6 Reset

The GT24C512A contains a reset function in case the

2-wire bus transmission on is accidentally interrupted (e.g. a power loss), or needs to be terminated mid-stream. The reset is initiated when the Master device creates a Start condition. To do this, it may be necessary for the Master device to monitor the SDA line while cycling the SCL up to nine times. (For each clock signal transition to High, the Master checks for a High level on SDA.)

### 5.7 Standby Mode

While in standby mode, the power consumption is minimal. The GT24C512A enters into standby mode during one of the following conditions: a) After Power-up, while no Op-code is sent; b) After the completion of an operation and followed by the Stop signal, provided that the previous operation is not Write related; or c) After the completion of any internal write operations.

### 5.8 Device Addressing

The Master begins a transmission on by sending a Start condition, then sends the address of the particular Slave devices to be communicated. The Slave device address is 8 bits format as shown in Figure. 5-5.

The four most significant bits of the Slave address are fixed (1010) for GT24C512A.

The next three bits, A0, A1 and A2, of the Slave address are specifically related to EEPROM. Up to eight GT24C512A units can be connected to the 2-wire bus.

The last bit of the Slave address specifies whether a Read or Write operation is to be performed. When this bit is set to 1, Read operation is selected. While it is set to 0, Write operation is selected.

After the Master transmits the Start condition and Slave address byte appropriately, the associated 2-wire Slave device, GT24C512A, will respond with ACK on the SDA line. Then GT24C512A will pull down the SDA on the ninth clock cycle, signaling that it received the eight bits of data.

The GT24C512A then prepares for a Read or Write operation by monitoring the bus.



# GT24C512A

## 5.9 Write Operation

### 5.9.1 Byte Write

In the Byte Write mode, the Master device sends the Start condition and the Slave address information (with the R/W set to Zero) to the Slave device. After the Slave generates an ACK, the Master sends the byte address that is to be written into the address pointer of the GT24C512A. After receiving another ACK from the Slave, the Master device transmits the data byte to be written into the address memory location. The GT24C512A acknowledges once more and the Master generates the Stop condition, at which time the device begins its internal programming cycle. While this internal cycle is in progress, the device will not respond to any request from the Master device.

### 5.9.2 Page Write

The GT24C512A is capable of 128-byte Page-Write operation. A Page-Write is initiated in the same manner as a Byte Write, but instead of terminating the internal Write cycle after the first data word is transferred, the Master device can transmit up to 127 more bytes. After the receipt of each data word, the EEPROM responds immediately with an ACK on SDA line, and the seven lower order data word address bits are internally incremented by one, while the higher order bits of the data word address remain constant. If a byte address is incremented from the last byte of a page, it returns to the first byte of that page. If the Master device should transmit more than 128 bytes prior to issuing the Stop condition, the address counter will “roll over,” and the previously written data will be overwritten. Once all 128 bytes are received and the Stop condition has been sent by the Master, the internal programming cycle begins. At this point, all received data is written to the GT24C512A in a single Write cycle. All inputs are disabled until completion of the internal Write cycle.

### 5.9.3 Acknowledge (ACK) Polling

The disabling of the inputs can be used to take advantage of the typical Write cycle time. Once the Stop condition is issued to indicate the end of the host's Write operation, the GT24C512A initiates the internal Write cycle. ACK polling

can be initiated immediately. This involves issuing the Start condition followed by the Slave address for a Write operation. If the EEPROM is still busy with the Write operation, no ACK will be returned. If the GT24C512A has completed the Write operation, an ACK will be returned and the host can then proceed with the next Read or Write operation.

### 5.9.4 Write Identification Page

The Identification Page (128 bytes) is an additional page which can be written and (later) permanently locked in Read-only mode. It is written by issuing the Write Identification Page instruction. This instruction uses the same protocol and format as Page Write (into memory array), except for the following differences:

- Device type identifier=1011b
- MSB address bits A15/A7 are don't care except for address bit A10 which must be '0'. LSB address bits A6/A0 define the byte address inside the Identification page.

If the Identification page is locked, the data bytes transferred during the Write Identification Page instruction are not acknowledged (NoACK).

### 5.9.5 Lock Identification Page

The Lock Identification Page instruction (Lock ID) permanently locks the Identification page in Read-only mode. The lock ID instruction is similar to Byte Write (into memory array) with the following specific condition:

- Device type identifier=1011b
- Address bit A10 must be '1'; all other address bits are don't care
- The data byte must be equal to the binary value xxxx xx1x, where x is don't care



# GT24C512A

## 5.10 Read Operation

Read operations are initiated in the same manner as Write operations, except that the (R/W) bit of the Slave address is set to “1”. There are three Read operation options: current address read, random address read and sequential read.

### 5.10.1 Current Address Read

The GT24C512A contains an internal address counter which maintains the address of the last byte accessed, incremented by one. For example, if the previous operation is either a Read or Write operation addressed to the address location  $n$ , the internal address counter would increment to address location  $n+1$ . When the EEPROM receives the Slave Addressing Byte with a Read operation (R/W bit set to “1”), it will respond an ACK and transmit the 8-bit data byte stored at address location  $n+1$ . The Master should not acknowledge the transfer but should generate a Stop condition so the GT24C512A discontinues transmission. If 'n' is the last byte of the memory, the data from location '0' will be transmitted. (Refer to Figure 5-8. Current Address Read Diagram.)

### 5.10.2 Random Address Read

Selective Read operations allow the Master device to select at random any memory location for a Read operation. The Master device first performs a 'dummy' Write operation by sending the Start condition, Slave address and byte address of the location it wishes to read. After the GT24C512A acknowledges the byte address, the Master device resends the Start condition and the Slave address, this time with the R/W bit set to one. The EEPROM then responds with its ACK and sends the data requested. The Master device does not send an ACK but will generate a Stop condition. (Refer to Figure 5-9. Random Address Read Diagram.)

### 5.10.3 Sequential Read

Sequential Reads can be initiated as either a Current Address Read or Random Address Read. After the GT24C512A sends the initial byte sequence, the Master device now responds with an ACK indicating it requires additional data from the GT24C512A. The EEPROM

continues to output data for each ACK received. The Master device terminates the sequential Read operation by pulling SDA High (no ACK) indicating the last data word to be read, followed by a Stop condition. The data output is sequential, with the data from address  $n$  followed by the data from address  $n+1, n+2 \dots$  etc. The address counter increments by one automatically, allowing the entire memory contents to be serially read during sequential Read operation. When the memory address boundary of the array is reached, the address counter “rolls over” to address 0, and the device continues to output data. (Refer to Figure 5-10. Sequential Read Diagram).

### 5.10.4 Read Identification Page

The Identification Page can be read by issuing an Read Identification Page instruction. This instruction uses the same protocol and format as the Random Address Read (from memory array) with device type identifier defined as 1011b. The MSB address bits A15/A7 are don't care, the LSB address bits A6/A0 define the byte address inside the Identification Page. The number of bytes to read in the ID page must not exceed the page boundary (e.g.:when reading the Identification Page from location 100d, the number of bytes should be less than or equal to 28, as the ID page boundary is 128 bytes).

### 5.10.5 Read the lock status

The locked/unlocked status of the Identification page can be checked by transmitting a specific truncated command [Identification page is unlocked, otherwise a NoACK bit if the Identification page is locked.

Right after this, it is recommended to transmit to the device a start followed by a Stop condition, so that:

- Start: the truncated command is not executed because the Start condition resets the device internal logic.
- Stop: the device is then set back into Standby mode by the Stop condition.





# GT24C512A

## 5.11 Diagrams

Figure 5-1. Typical System Bus Configuration

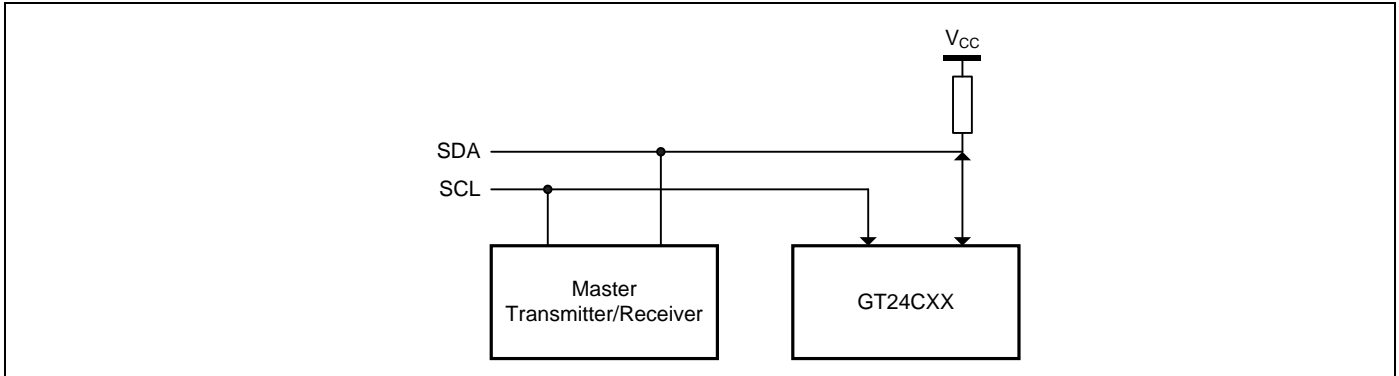


Figure 5-2. output Acknowledge

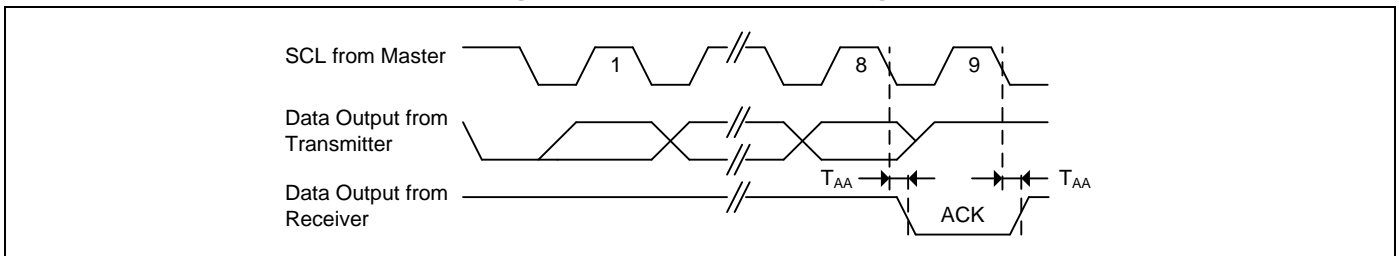


Figure 5-3. Start and Stop Conditions

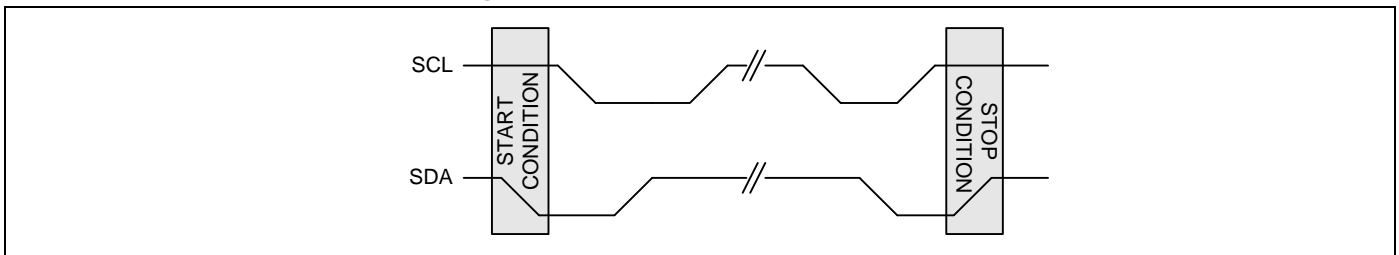
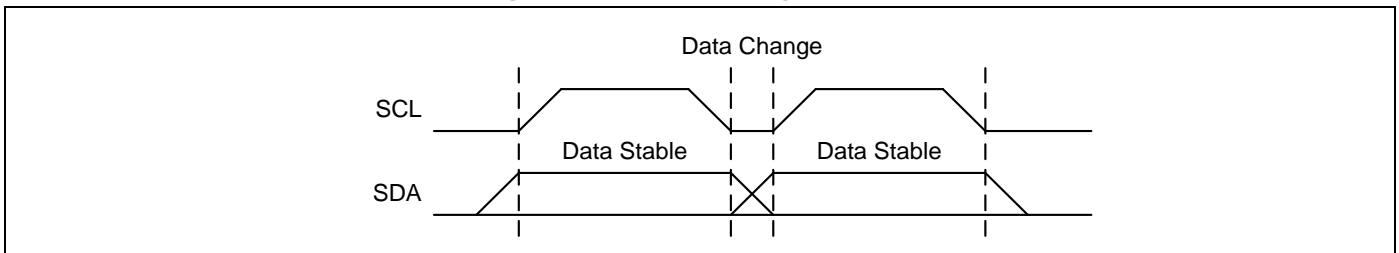


Figure 5-4. Data Validity Protocol





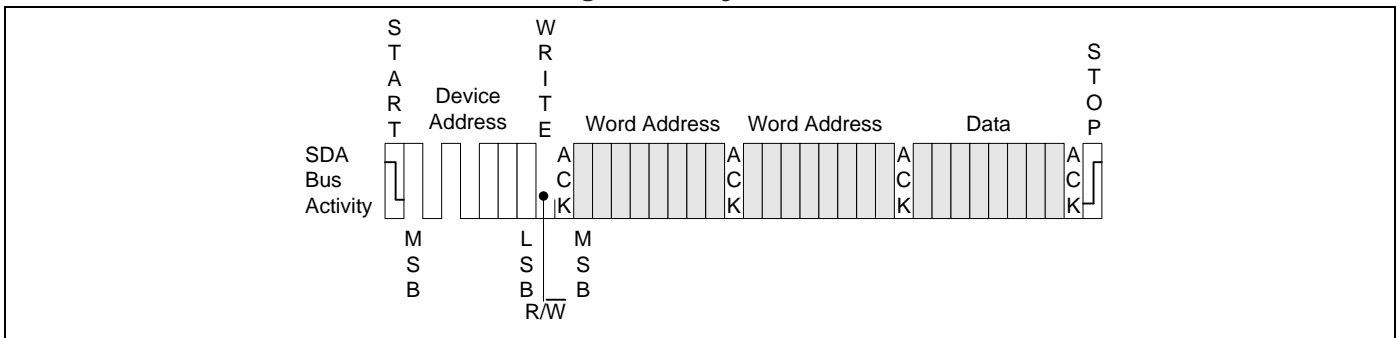
# GT24C512A

**Figure 5-5. Slave Address**

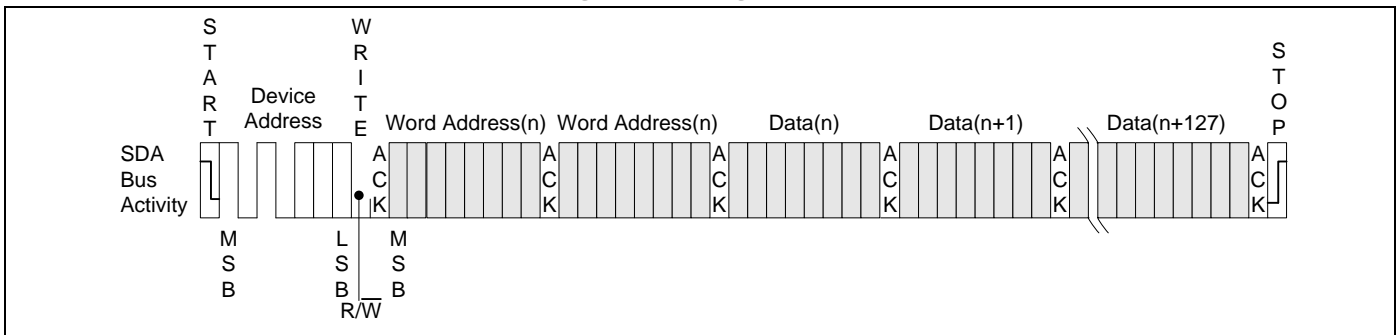
	Device type identifier <sup>(1)</sup>				Chip Enable address <sup>(2)</sup>			R / $\bar{W}$
	b7	b6	b5	b4	b3	b2	b1	b0
Device select code when addressing the memory array	1	0	1	0	A2	A1	A0	R / $\bar{W}$
Device select code when accessing the Identification page	1	0	1	1	A2	A1	A0	R / $\bar{W}$

1. The most significant bit, b7, is sent first.  
 2. A0, A1 and A2 are compared with the value read on input pins A0, A1, and A2.

**Figure 5-6. Byte Write**

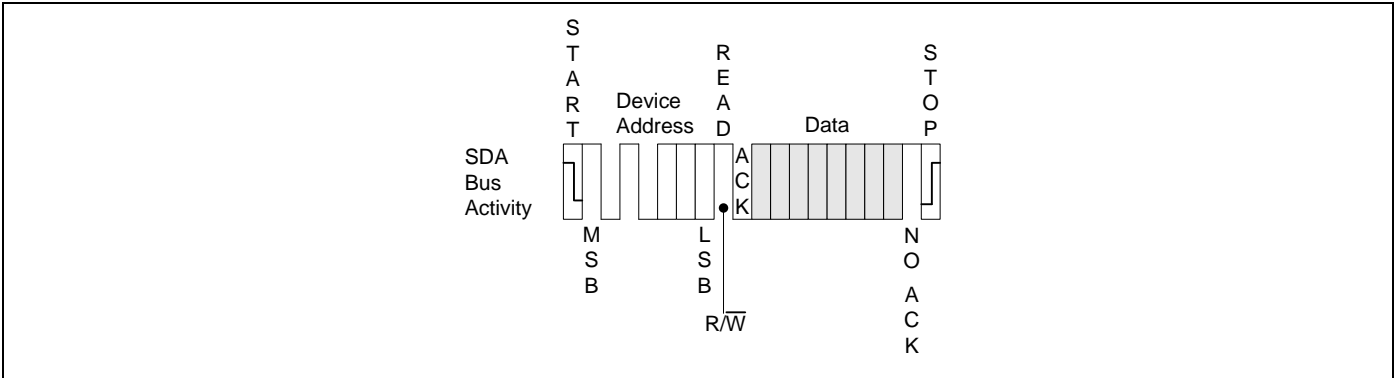


**Figure 5-7. Page Write**

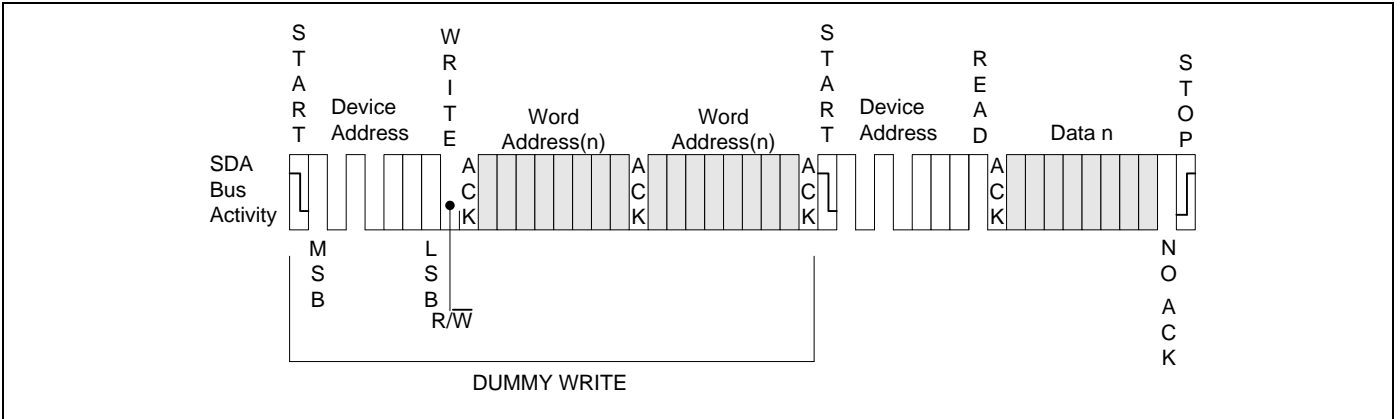




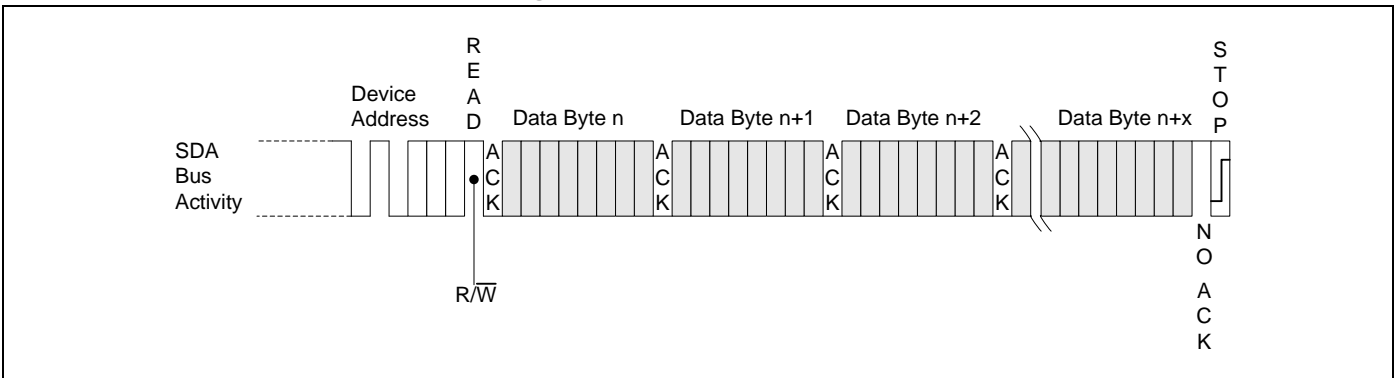
**Figure 5-8. Current Address Read**



**Figure 5-9. Random Address Read**



**Figure 5-10. Sequential Read**





# GT24C512A

## 5.12 Timing Diagrams

Figure 5-11. Bus Timing

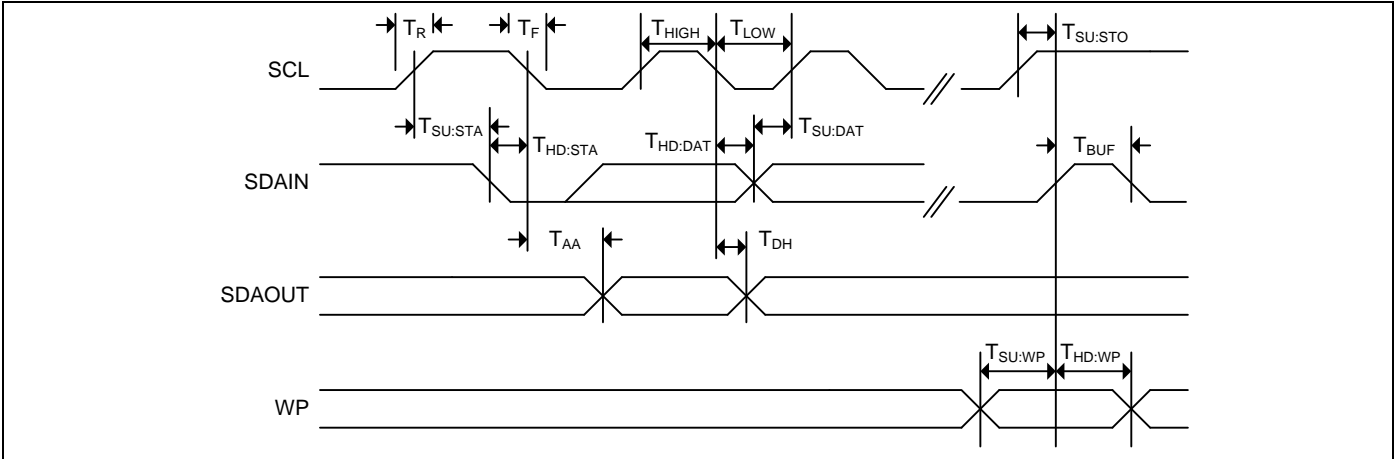
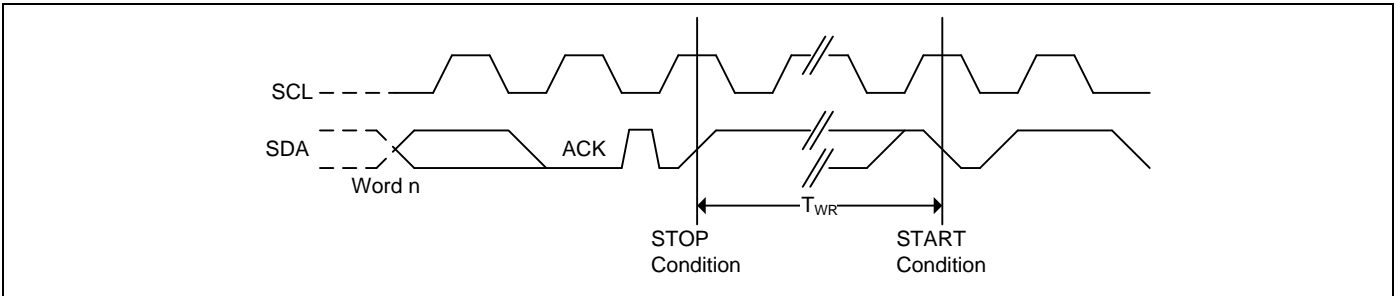


Figure 5-12. Write Cycle Timing





# GT24C512A

## 6. Electrical Characteristics

### 6.1 Absolute Maximum Ratings

Symbol	Parameter	Value	Unit
$V_S$	Supply Voltage	-0.5 to $V_{CC} + 1$	V
$V_P$	Voltage on Any Pin	-0.5 to $V_{CC} + 1$	V
$T_{BIAS}$	Temperature Under Bias	-40 to +105	°C
$T_{STG}$	Storage Temperature	-65 to +125	°C
$I_{OUT}$	Output Current	5	mA

Note: Stress greater than those listed under Absolute Maximum Ratings may cause permanent damage to the device. This is a stress rating only and functional operation of the device at these or any other condition outside those indicated in the operational sections of this specification is not implied. Exposure to absolute maximum rating conditions for extended periods may affect reliability.

### 6.2 Operating Range

Range	Ambient Temperature ( $T_A$ )	$V_{CC}$
Automotive Grade 2	-40°C to +105°C	2.5V to 5.5V

### 6.3 Reliability

Ambient Temperature ( $T_A$ )	Symbol	Parameter	Min.	Unit
$T_a=+25^\circ\text{C}$	End	Endurance	1 million	Program / Erase Cycles
	DR	Data Retention	100	Years

### 6.4 Capacitance

Symbol	Parameter <sup>[1, 2]</sup>	Conditions	Max.	Unit
$C_{IN}$	Input Capacitance	$V_{IN} = 0V$	6	pF
$C_{I/O}$	Input / Output Capacitance	$V_{I/O} = 0V$	8	pF

Notes: <sup>[1]</sup> Tested initially and after any design or process changes that may affect these parameters and not 100% tested.

<sup>[2]</sup> Test conditions:  $T_A = 25^\circ\text{C}$ ,  $f = 1\text{ MHz}$ ,  $V_{CC} = 5.0V$ .



# GT24C512A

## 6.5 DC Electrical Characteristic

Automotive:  $T_A = -40^{\circ}\text{C}$  to  $+105^{\circ}\text{C}$ ,  $V_{CC} = 2.5\text{V} \sim 5.5\text{V}$

Symbol	Parameter <sup>(1)</sup>	V <sub>CC</sub>	Test Conditions	Min.	Typ.	Max.	Unit
V <sub>CC</sub>	Supply Voltage			2.5		5.5	V
V <sub>IH</sub>	Input High Voltage			0.7*V <sub>CC</sub>		V <sub>CC</sub> +1	V
V <sub>IL</sub>	Input Low Voltage			-0.5		0.3* V <sub>CC</sub>	V
I <sub>LI</sub>	Input Leakage Current	5.5V	V <sub>IN</sub> = V <sub>CC</sub> max	--		2	μA
I <sub>LO</sub>	Output Leakage Current	5.5V		--		2	μA
V <sub>OL</sub>	Output Low Voltage	3V	I <sub>OL</sub> = 2.1 mA	—		0.4	V
I <sub>SB1</sub>	Standby Current	2.5V	V <sub>IN</sub> = V <sub>CC</sub> or GND	—		2	μA
I <sub>SB2</sub>	Standby Current	5.5V	V <sub>IN</sub> = V <sub>CC</sub> or GND	—		3	μA
I <sub>CC1</sub>	Read Current	2.5V	Read at 1 MHz			0.2	mA
		5.5V	Read at 1 MHz			0.5	mA
I <sub>CC2</sub>	Write Current	2.5V	Write at 1 MHz			0.6	mA
		5.5V	Write at 1 MHz			1	mA

Note: The parameters are characterized but not 100% tested.



# GT24C512A

## 6.6 AC Electrical Characteristic

Automotive:  $T_A = -40^{\circ}\text{C}$  to  $+105^{\circ}\text{C}$ , Supply voltage = 2.5V to 5.5V

Symbol	Parameter [1] [2]	Min.	Max.	Unit
$F_{\text{SCL}}$	SCK Clock Frequency		1000	KHz
$T_{\text{LOW}}$	Clock Low Period	400	—	ns
$T_{\text{HIGH}}$	Clock High Period	400	—	ns
$T_{\text{R}}$	Rise Time (SCL and SDA)	—	300	ns
$T_{\text{F}}$	Fall Time (SCL and SDA)	—	100	ns
$T_{\text{SU:STA}}$	Start Condition Setup Time	200	—	ns
$T_{\text{SU:STO}}$	Stop Condition Setup Time	200	—	ns
$T_{\text{HD:STA}}$	Start Condition Hold Time	200	—	ns
$T_{\text{SU:DAT}}$	Data In Setup Time	40	—	ns
$T_{\text{HD:DAT}}$	Data In Hold Time	0	—	ns
$T_{\text{AA}}$	Clock to Output Access time (SCL Low to SDA Data Out Valid)	50	400	ns
$T_{\text{DH}}$	Data Out Hold Time (SCL Low to SDA Data Out Change)	50	—	ns
$T_{\text{WR}}$	Write Cycle Time	—	5	ms
$T_{\text{BUF}}$	Bus Free Time Before New Transmission	400	—	ns
$T_{\text{SU:WP}}$	WP pin Setup Time	400	—	ns
$T_{\text{HD:WP}}$	WP pin Hold Time	1200	—	ns
$T$	Noise Suppression Time	—	50	ns

Notes: <sup>[1]</sup> The parameters are characterized but not 100% tested.

<sup>[2]</sup> AC measurement conditions:

$R_L$  (connects to  $V_{\text{CC}}$ ): 1.3 k $\Omega$  (2.5V, 5.5V)

$C_L = 100$  pF

Input pulse voltages:  $0.3 \cdot V_{\text{CC}}$  to  $0.7 \cdot V_{\text{CC}}$

Input rise and fall times:  $\leq 50$  ns

Timing reference voltages: half  $V_{\text{CC}}$  level



# GT24C512A

---

## 7. Ordering Information

**Automotive Grade: -40°C to +105°C, Lead-free**

<b>Voltage Range</b>	<b>Part Number*</b>	<b>Package (8-pin)*</b>
2.5V to 5.5V	GT24C512A-3GLA2-TR	150-mil SOIC
	GT24C512A-3ZLA2-TR	3 x 4.4 mm TSSOP
	GT24C512A-3UDLA2-TR	2 x 3 x 0.55 mm UDFN

\*

1. Contact Giantec Sales Representatives for availability and other package information.
2. The product is packed in tape and reel “-TR” (4K per reel), except UDFN is 5K per reel.
3. Refer to Giantec website for related declaration document on lead free, RoHS, halogen free or Green, whichever is applicable.





# GT24C512A

## 8. Top Markings

### 8.1 SOIC Package



**G:** Giantec Logo

4512A3GX: GT24C512A-3GLA2-TR

YWW: Date Code, Y=year, WW=week

### 8.2 TSSOP Package



**GT:** Giantec Logo

4512A3ZX: GT24C512A-3ZLA2-TR

YWW: Date Code, Y=year, WW=week

### 8.3 UDFN Package



**GT:** Giantec Logo

49A2: GT24C512A-3UDLA2-TR

YWW: Date Code, Y=year, WW=week

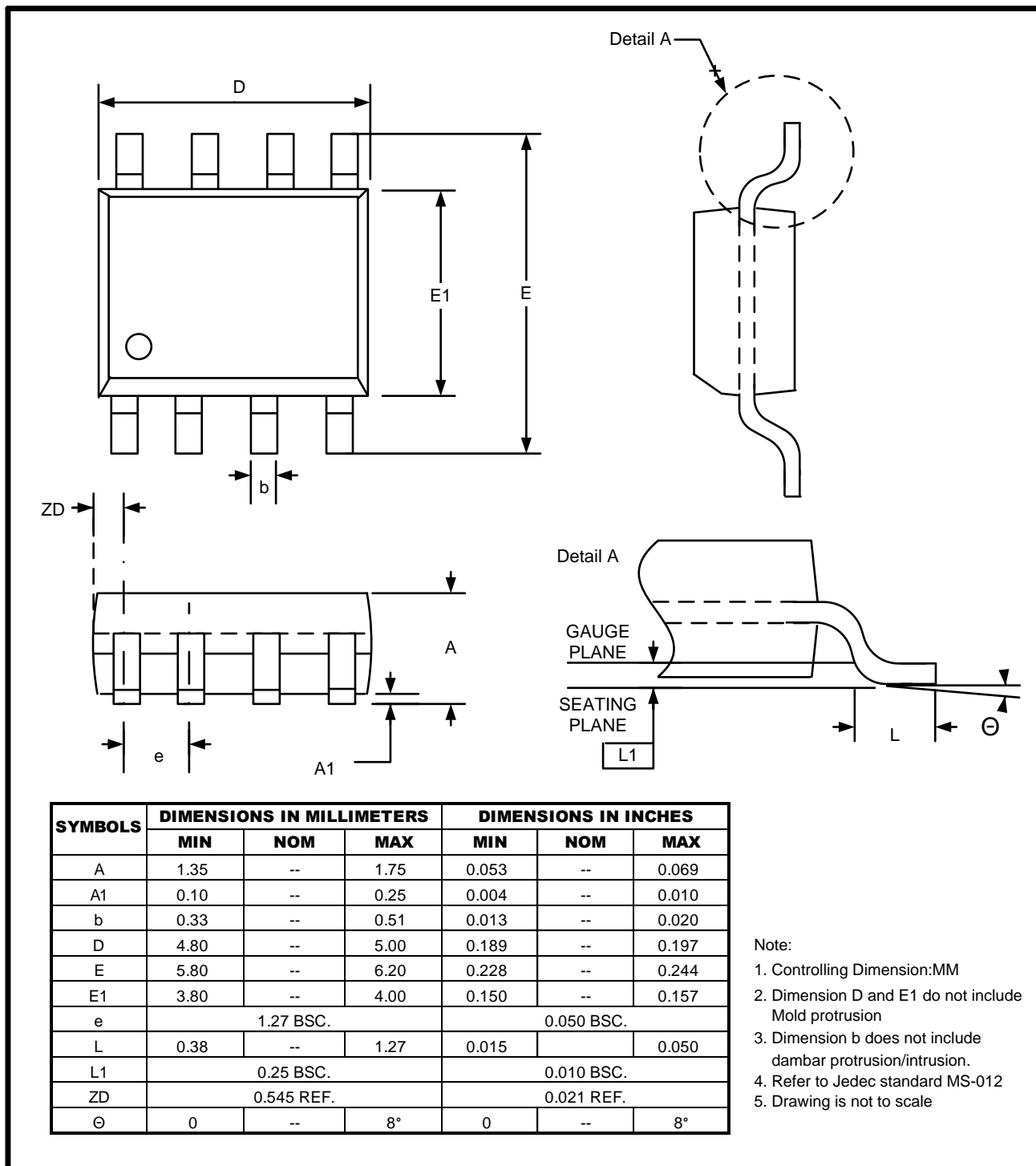


# GT24C512A

## 9. Package Information

### 9.1 SOIC

#### 8L 150mil SOIC Package Outline

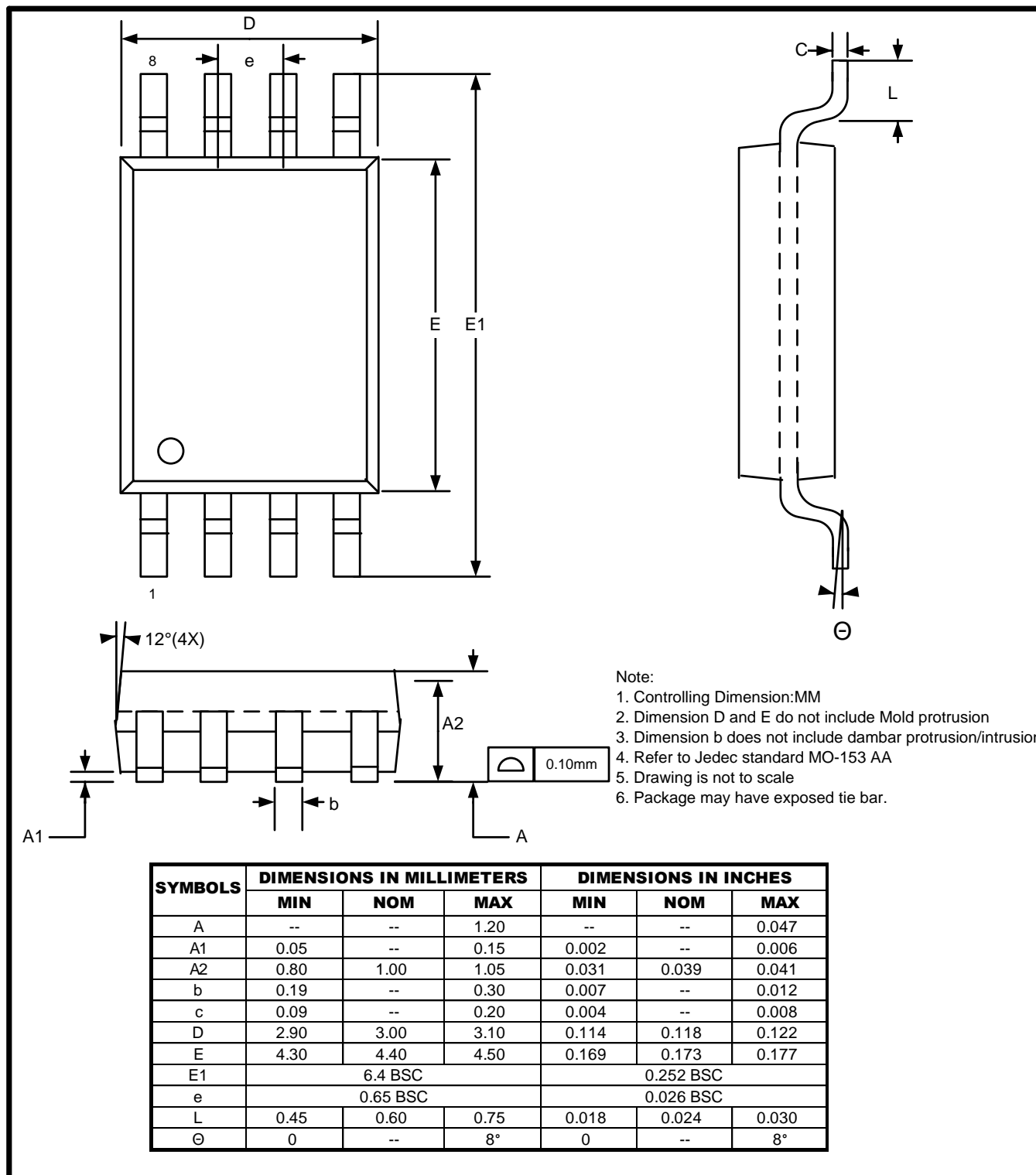




# GT24C512A

## 9.2 TSSOP

### 8L 3x4.4mm TSSOP Package Outline

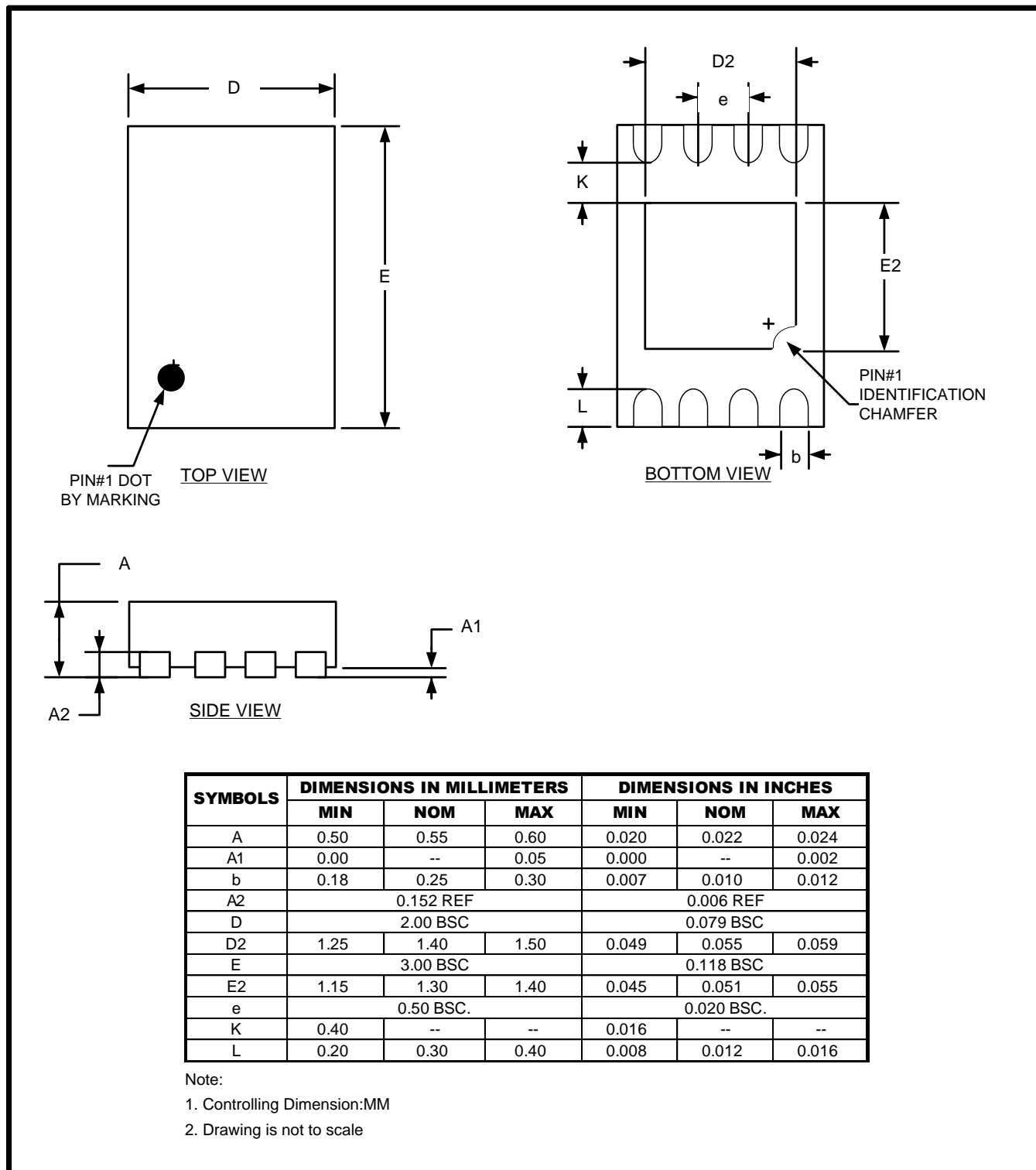




# GT24C512A

## 9.3 UDFN

### 8L 2x3mm UDFN Package Outline





# **GT24C512A**

---

## **10. Revision History**

<b>Revision</b>	<b>Date</b>	<b>Descriptions</b>
A0	Oct.2015	Initial version