

Harvatek High Power LED Datasheet

Model No : HT-CTP5



Official Product	HT Part No HT- CTP5	Your Part No.		Data Sheet No.
Tentative Product	*****	*****		
Specifications are subject to changes for improvement without advance notice. Proprietary data, drawings, and company confidential all rights reserved.		Aug-04, 2017	Version of 1.2	Page 1/21



- Dimension : 17.85x17.85 mm
- Typical Im : 20W CW 2700 @550mA
20W WW 2550 @550mA
30W CW 3900 @800mA
30W WW 3750 @800mA
- Color Temperature : CW/NW/WW
- CRI : CW>80 WW>80 , CW>90 WW>90
- High CRI can be available
- Thermal Resistance : 1.1°C/W

Table of Contents

DISCLAIMER.....	3
Life Support Policy.....	3
Product Specification.....	4
Electro-Optical Absolute Maximum Rating.....	5
Electrical Characteristic.....	5
Flux Characteristic, Order Code.....	6
BIN Code Definition.....	7
Color Coordinates Temperature.....	7
Product Outline Dimension.....	12
Characteristic Curve.....	13
Precaution for Use.....	16
Label Spec.....	17
Packing Model.....	18
Handling of Silicone Resin LEDs.....	19
Reflow Soldering.....	20
Reworking.....	21
Cleaning.....	21
Cautions of Pick and Place.....	21
Storage.....	21

Official Product	HT Part No HT- CTP5	Your Part No.		Data Sheet No.
Tentative Product	*****	*****		
Specifications are subject to changes for improvement without advance notice. Proprietary data, drawings, and company confidential all rights reserved.		Aug-04, 2017	Version of 1.2	Page 2/21

DISCLAIMER

HARVATEK reserves the right to make changes without further notice to any products herein to improve reliability, function or design. HARVATEK does not assume any liability arising out of the application or use of any product or circuit described herein; neither does it convey any license under its patent rights, nor the rights of others.

Life Support Policy

HARVATEK's products are not authorized for use as critical components in life support devices or systems without the express written approval of the President of HARVATEK or HARVATEK INTERNATIONAL. As used herein:

1. Life support devices or systems are devices or systems which, (a) are intended for surgical implant into the body, or (b) support or sustain life, and (c) whose failure to perform when properly used in accordance with instructions for use provided in the labeling, can be reasonably expected to result in a significant injury of the user.
2. A critical component in any component of a life support device or system whose failure to perform can be reasonably expected to cause the failure of the life support device or system, or to affect its safety or effectiveness.

Official Product	HT Part No HT- CTP5	Your Part No.		Data Sheet No.
Tentative Product	*****	*****		
Specifications are subject to changes for improvement without advance notice. Proprietary data, drawings, and company confidential all rights reserved.		Aug-04, 2017	Version of 1.2	Page 3/21

Product Specification

	Specification	Material	Quantity
Dimension	17.85x17.85x1.95 mm	Ceramic Substrate	
LES	12 mm		
V _F	Typical 36 V @ 550 mA/Ta = 25 °C @ 800 mA/Ta = 25 °C		
Resin		Silicone	
Tray	304 mm × 195 mm		56 pcs per tray
Label	HT standard	Paper	
Carton	HT standard	Paper	Non-specified

Others:

Each immediate box consists of 15 trays. The 15 trays may not necessarily have the same lot number or the same bin combinations of I_v, λ_D and V_f. Each reel has a label identifying its specification; the immediate box consists of a product label as well.

Note :This is shipped test conditions

※Remarks: This product should be operated in forward bias. If a reverse voltage is continuously applied to the product, such operation can cause migration resulting in LED damage.

ATTENTION: Electric Static Discharge (ESD) protection



The symbol shown on the page herein to introduce 'Electro-Optical Characteristics'. ESD protection for GaP and AlGaAs based chips is still necessary even though they are safe in low static-electric discharge. Parts built with AlInGaP, GaN, or/and InGaN based chips are **STATIC SENSITIVE devices**. ESD protection has to considered and taken in the initial design stage.

If manual work/process is needed, please ensure the device is well protected from ESD during all the process.

Official Product	HT Part No HT- CTP5	Your Part No.		Data Sheet No.
Tentative Product	*****	*****		
Specifications are subject to changes for improvement without advance notice. Proprietary data, drawings, and company confidential all rights reserved.		Aug-04, 2017	Version of 1.2	Page 4/21

Electro-Optical Absolute Maximum Ratings

(T_a =25°C)

Parameter	Rating	Unit	Conditions
DC Forward Current ^{*1}	800	mA	-
LED junction Temperature	≤ 120	°C	-
Operating Temperature	-30~+85	°C	-
Storage Temperature	-40~+100	°C	-
Soldering Temperature	260	°C	For 5 sec. Max.

*1: Proper current derating must be observed to maintain junction temperature below the maximum.

Electrical Characteristics

(T_a =25°C)

Parameter	Symbol	Min.	TYP.	Max.	Unit
Viewing angle	2θ _{1/2}	115	-	-	Deg.
Forward Voltage (I _F =550 mA) (I _F =800 mA)	V _F	34	36	40	V
Thermal Resistance Junction to Board (I _F =550 mA) (I _F =800 mA)	Rθ _{J-B}	-	1.1	-	°C/W

Note:

1. It maintains a tolerance of ±5% on forward voltage measurements.

Official Product	HT Part No HT- CTP5	Your Part No.		Data Sheet No.
Tentative Product	*****	*****		
Specifications are subject to changes for improvement without advance notice. Proprietary data, drawings, and company confidential all rights reserved.		Aug-04, 2017	Version of 1.2	Page 5/21

Flux Characteristics, Order Code

CCT Range	CRI		Typical Flux@550mA		Order Code
	Min	Type	Flux(lm) @85 °C	Flux(lm) @25 °C	
3000K	80	--	2240	2550	CTP5WCMDB1ASGDW050
4000K	80	--	2330	2650	CTP5NCMDB1ASGDN040
5000K	80	--	2370	2700	CTP5CCMDB1ASGDC040
3000K	95	--	2040	2350	CTP5WTAMB1ASGDW090
4000K	92	--	2080	2400	CTP5NTAJB1ASGDN130
5000K	90	--	2120	2450	CTP5CTAEB1ASGDC090

CCT Range	CRI		Typical Flux@800mA		Order Code
	Min	Type	Flux(lm) @85 °C	Flux(lm) @25 °C	
3000K	80	--	3250	3750	CTP5WCMB6ASGDW050
4000K	80	--	3350	3850	CTP5NCMDB6ASGDN040
5000K	80	--	3450	3900	CTP5CCMDB6ASGDC040
3000K	95	--	2550	2900	CTP5WTAMB6ASGDW090
4000K	92	--	2950	3300	CTP5NTAJB6ASGDN130
5000K	90	--	3050	3500	CTP5CTAEB6ASGDC090

Note:

1. It maintains a tolerance of $\pm 10\%$ on flux.
2. Flux values @ 85°C are calculated and for reference only.
3. It maintains a tolerance of ± 2 on CRI.

Official Product	HT Part No HT- CTP5	Your Part No.		Data Sheet No.
Tentative Product	*****	*****		
Specifications are subject to changes for improvement without advance notice. Proprietary data, drawings, and company confidential all rights reserved.		Aug-04, 2017	Version of 1.2	Page 6/21

BIN Code Definition

The following describes luminous flux group and color group.

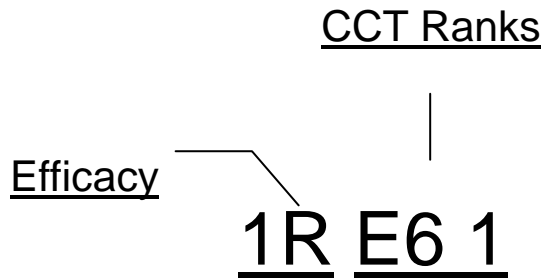

Color Coordinates Temperature

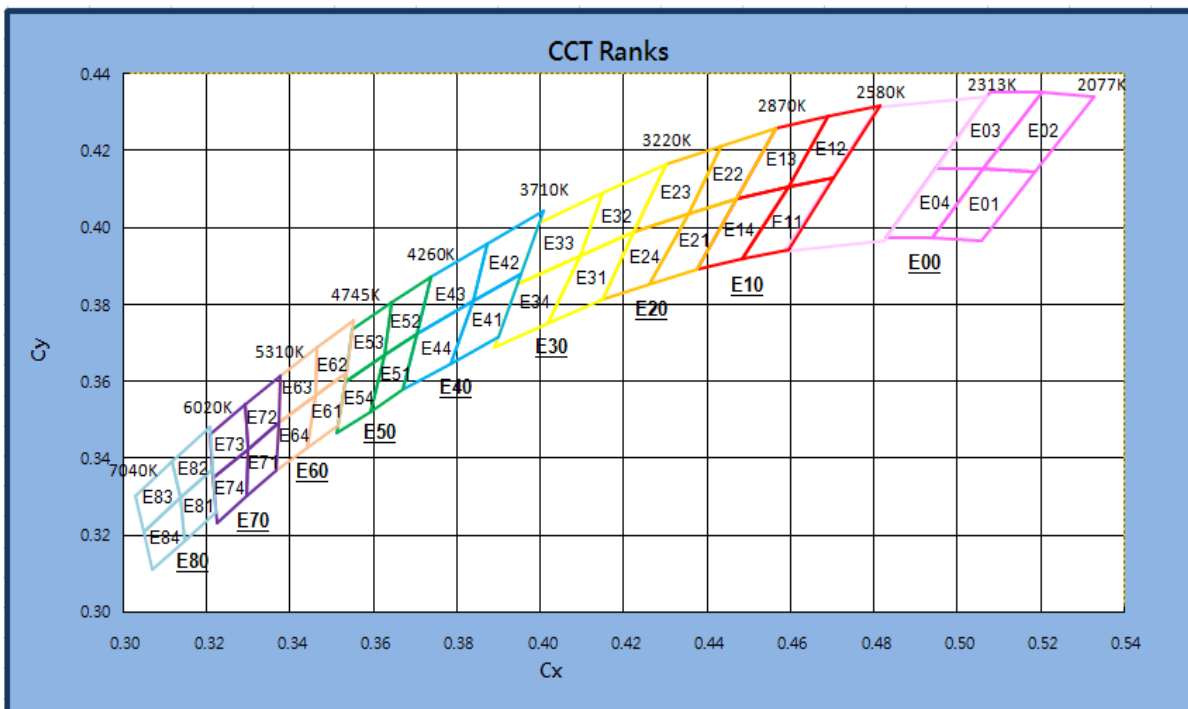

<Figure1 CCT Rank>

Official Product	HT Part No HT- CTP5	Your Part No.		Data Sheet No.
Tentative Product	*****	*****		
Specifications are subject to changes for improvement without advance notice. Proprietary data, drawings, and company confidential all rights reserved.		Aug-04, 2017	Version of 1.2	Page 7/21

Table 1-1-1. Light efficacy_RA80

Main BIN No.	lm/W		Secondary BIN No.	lm/W		Warm White (WW)				Neutral White (NW)		Cool White (CW)		
	min.	max.		min.	max.	E00	E10	E20	E30	E40	E50	E60	E70	E80
						2200K	2700K	3000K	3500K	4000K	4500K	5000K	5700K	6500K
J	10	25	1J	10	17									
			2J	17	25									
K	25	40	1K	25	32									
			2K	32	40									
L	40	62	1L	40	51									
			2L	51	62									
M	62	70	1M	62	66									
			2M	66	70									
N	70	85	1N	70	77									
			2N	77	85									
P	85	100	1P	85	92									
			2P	92	100									
Q	100	115	1Q	100	107									
			2Q	107	115									
R	115	130	1R	115	122									
			2R	122	130			Main						
S	130	145	1S	130	137			Main		Main				
			2S	137	145			Main		Main		Main		
T	145	160	1T	145	152							Main		
			2T	152	160									
U	160	175	1U	160	167									
			2U	167	175									
V	175	190	1V	175	182									
			2V	182	190									
W	190	205	1W	190	197									
			2W	197	205									

Official Product	HT Part No HT- CTP5	Your Part No.		Data Sheet No.
Tentative Product	*****	*****		
Specifications are subject to changes for improvement without advance notice. Proprietary data, drawings, and company confidential all rights reserved.		Aug-04, 2017	Version of 1.2	Page 8/21

Table 1-1-2. Light efficacy_RA90

Main BIN No.	lm/W		Secondary BIN No.	lm/W		Warm White (WW)				Neutral White (NW)		Cool White (CW)		
	min.	max		min.	max.	E00	E10	E20	E30	E40	E50	E60	E70	E80
						2200K	2700K	3000K	3500K	4000K	4500K	5000K	5700K	6500K
J	10	25	1J	10	17									
			2J	17	25									
K	25	40	1K	25	32									
			2K	32	40									
L	40	62	1L	40	51									
			2L	51	62									
M	62	70	1M	62	66									
			2M	66	70									
N	70	85	1N	70	77									
			2N	77	85									
P	85	100	1P	85	92									
			2P	92	100									
Q	100	115	1Q	100	107			Main						
			2Q	107	115			Main		Main				
R	115	130	1R	115	122					Main		Main		
			2R	122	130							Main		
S	130	145	1S	130	137									
			2S	137	145									
T	145	160	1T	145	152									
			2T	152	160									
U	160	175	1U	160	167									
			2U	167	175									
V	175	190	1V	175	182									
			2V	182	190									
W	190	205	1W	190	197									
			2W	197	205									

Official Product	HT Part No HT- CTP5	Your Part No.		Data Sheet No.
Tentative Product	*****	*****		
Specifications are subject to changes for improvement without advance notice. Proprietary data, drawings, and company confidential all rights reserved.		Aug-04, 2017	Version of 1.2	Page 9/21

Table 1-2. CCT ANSI C78.377A

BIN Code		E00	E10	E20	E30	E40	E50	E60	E70	E80
Nominal CCT(K)		2200	2700	3000	3500	4000	4500	5000	5700	6500
CCT Range(K)		2077~2313	2580-2870	2870-3220	3220-3710	3710-4260	4260-4745	4745-5310	5310-6020	6020-7040
Center	x	0.5061	0.4578	0.4338	0.4073	0.3818	0.3611	0.3447	0.3287	0.3123
	y	0.4152	0.4101	0.4030	0.3917	0.3797	0.3658	0.3553	0.3417	0.3282
Tolerance Quadrant	x	0.5056	0.4813	0.4562	0.4299	0.4006	0.3736	0.3551	0.3376	0.3205
	y	0.3968	0.4319	0.4260	0.4165	0.4044	0.3874	0.3760	0.3616	0.3481
	x	0.5328	0.4562	0.4299	0.3996	0.3736	0.3548	0.3376	0.3207	0.3028
	y	0.4342	0.4260	0.4165	0.4015	0.3874	0.3736	0.3616	0.3462	0.3304
	x	0.5076	0.4373	0.4147	0.3889	0.3670	0.3512	0.3366	0.3222	0.3068
	y	0.4352	0.3893	0.3814	0.3690	0.3578	0.3465	0.3369	0.3234	0.3113
	x	0.4827	0.4593	0.4373	0.4147	0.3898	0.3670	0.3515	0.3366	0.3221
	y	0.3974	0.3944	0.3893	0.3814	0.3716	0.3578	0.3487	0.3369	0.3261

Table 1-3. Secondary BIN No.

BIN Code	Secondary BIN No.	Position	CCT(K)		Tolerance Quadrant							
			Left	Right	Right Up		Left Up		Left	Down	Right Down	
			min.	max.	x	y	x	y	x	y	x	y
E00	E01	Down	2077	2195	0.5184	0.4144	0.5061	0.4152	0.4939	0.3975	0.5056	0.3968
	E02	Up			0.5328	0.4342	0.5200	0.4352	0.5061	0.4152	0.5184	0.4144
	E03	Up	2195	2313	0.5200	0.4352	0.5076	0.4352	0.4944	0.4152	0.5061	0.4152
	E04	Down			0.5061	0.4152	0.4944	0.4152	0.4827	0.3974	0.4939	0.3975
E10	E11	Down	2580	2725	0.4703	0.4132	0.4593	0.4106	0.4483	0.3919	0.4593	0.3944
	E12	Up			0.4813	0.4319	0.4688	0.4290	0.4593	0.4106	0.4703	0.4132
	E13	Up	2725	2870	0.4688	0.4290	0.4562	0.4260	0.4468	0.4077	0.4593	0.4106
	E14	Down			0.4593	0.4106	0.4468	0.4077	0.4373	0.3893	0.4483	0.3919
E20	E21	Down	2870	3045	0.4468	0.4077	0.4355	0.4037	0.4260	0.3854	0.4373	0.3893
	E22	Up			0.4562	0.4260	0.4431	0.4213	0.4355	0.4037	0.4468	0.4077
	E23	Up	3045	3220	0.4431	0.4213	0.4299	0.4165	0.4223	0.3990	0.4355	0.4037
	E24	Down			0.4355	0.4037	0.4223	0.3990	0.4147	0.3814	0.4260	0.3854
E30	E31	Down	3220	3465	0.4223	0.3990	0.4094	0.3928	0.4018	0.3752	0.4147	0.3814
	E32	Up			0.4299	0.4165	0.4148	0.4090	0.4094	0.3928	0.4223	0.3990
	E33	Up	3465	3710	0.4148	0.4090	0.3996	0.4015	0.3943	0.3853	0.4094	0.3928
	E34	Down			0.4094	0.3928	0.3943	0.3853	0.3889	0.3690	0.4018	0.3752

Official Product	HT Part No HT- CTP5	Your Part No.		Data Sheet No.
Tentative Product	*****	*****		
Specifications are subject to changes for improvement without advance notice. Proprietary data, drawings, and company confidential all rights reserved.		Aug-04, 2017	Version of 1.2	Page 10/21

E40	E41	Down	3710	3985	0.3952	0.3880	0.3838	0.3811	0.3784	0.3647	0.3898	0.3716
	E42	Up			0.4006	0.4044	0.3871	0.3959	0.3838	0.3811	0.3952	0.3880
	E43	Up	3985	4260	0.3871	0.3959	0.3736	0.3874	0.3703	0.3726	0.3838	0.3811
	E44	Down			0.3838	0.3811	0.3703	0.3726	0.3670	0.3578	0.3784	0.3647
E50	E51	Down	4260	4502.5	0.3703	0.3726	0.3624	0.3670	0.3591	0.3522	0.3670	0.3578
	E52	Up			0.3736	0.3874	0.3642	0.3805	0.3624	0.3670	0.3703	0.3726
	E53	Up	4502.5	4745	0.3642	0.3805	0.3548	0.3736	0.3530	0.3601	0.3624	0.3670
	E54	Down			0.3624	0.3670	0.3530	0.3601	0.3512	0.3465	0.3591	0.3522
E60	E61	Down	4745	5027.5	0.3533	0.3624	0.3459	0.3565	0.3441	0.3428	0.3515	0.3487
	E62	Up			0.3551	0.3760	0.3464	0.3688	0.3459	0.3565	0.3533	0.3624
	E63	Up	5027.5	5310	0.3464	0.3688	0.3376	0.3616	0.3371	0.3493	0.3459	0.3565
	E64	Down			0.3459	0.3565	0.3371	0.3493	0.3366	0.3369	0.3441	0.3428
E70	E71	Down	5310	5665	0.3371	0.3493	0.3299	0.3425	0.3294	0.3302	0.3366	0.3369
	E72	Up			0.3376	0.3616	0.3292	0.3539	0.3299	0.3425	0.3371	0.3493
	E73	Up	5665	6020	0.3292	0.3539	0.3207	0.3462	0.3215	0.3348	0.3299	0.3425
	E74	Down			0.3299	0.3425	0.3215	0.3348	0.3222	0.3234	0.3294	0.3302
E80	E81	Down	6020	6530	0.3213	0.3371	0.3137	0.3297	0.3145	0.3187	0.3221	0.3261
	E82	Up			0.3205	0.3481	0.3117	0.3393	0.3137	0.3297	0.3213	0.3371
	E83	Up	6530	7040	0.3117	0.3393	0.3028	0.3304	0.3048	0.3209	0.3137	0.3297
	E84	Down			0.3137	0.3297	0.3048	0.3209	0.3068	0.3113	0.3145	0.3187

BIN	Secondary BIN No.	Steps	CCT(K)	Ceter Point		Oval parameter		
				x	y	Major Axis a	Minor Axis b	Ellipse Rotation Angle θ
E10	E16	5	2700	0.4579	0.4101	0.01350	0.00700	53.7
E20	E26	5	3000	0.4338	0.4030	0.01390	0.00680	53.2
E30	E36	5	3500	0.4073	0.3917	0.01545	0.00690	54.0
E40	E46	5	4000	0.3818	0.3797	0.01565	0.00670	53.7
E50	E56	5	4500	0.3611	0.3658	0.01468	0.00630	56.7
E60	E66	5	5000	0.3447	0.3553	0.01370	0.00590	59.6
E70	E76	5	5700	0.3287	0.3417	0.01243	0.00533	59.1
E80	E86	5	6500	0.3123	0.3282	0.01115	0.00475	58.6

Note:It maintains a tolerance of $\pm 5\%$ on CCT.

Official Product	HT Part No HT- CTP5	Your Part No.		Data Sheet No.
Tentative Product	*****	*****		
Specifications are subject to changes for improvement without advance notice. Proprietary data, drawings, and company confidential all rights reserved.		Aug-04, 2017	Version of 1.2	Page 11/21

Product Feature

- High efficiency
- Wide view angle
- Easy to be fixed
- No UV
- Long operating time
- High Brightness
- More energy efficient than incandescent and most halogen lamps
- Low thermal resistance
- Color uniformity

Application

- General Lighting application
Bulb/Spot light

Product Outline Dimension

● Top View

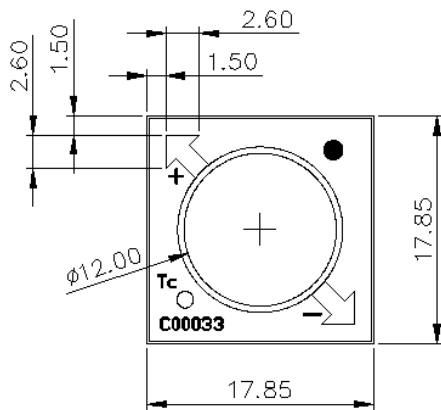

● Side View

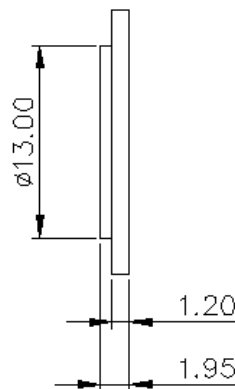

Unit:mm

Unless otherwise specified, tolerances are ± 0.30 mm.

<Figure2 Drawing for part no. CTP5>

● Current Layout

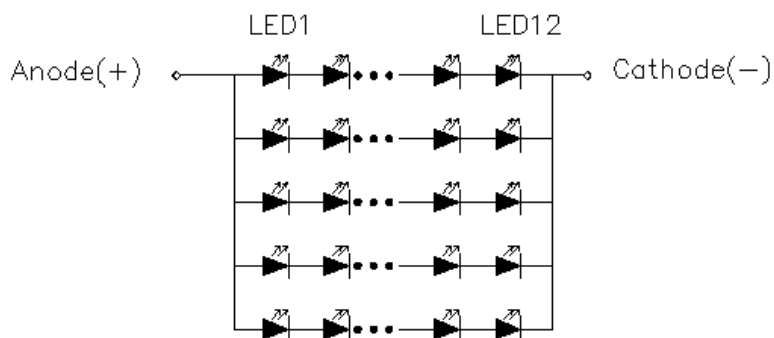

Official Product	HT Part No HT- CTP5	Your Part No.		Data Sheet No.
Tentative Product	*****	*****		
Specifications are subject to changes for improvement without advance notice. Proprietary data, drawings, and company confidential all rights reserved.		Aug-04, 2017	Version of 1.2	Page 12/21

Characteristics Curve

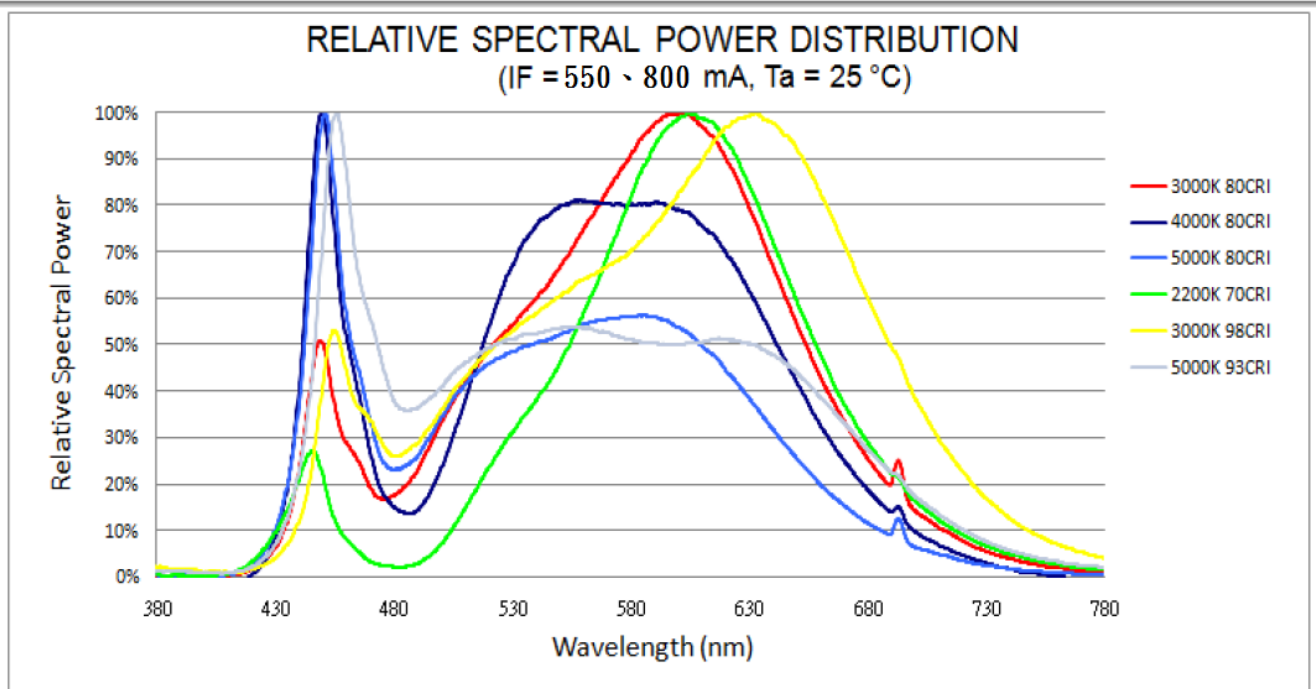

<Figure3 Color Spectrum>

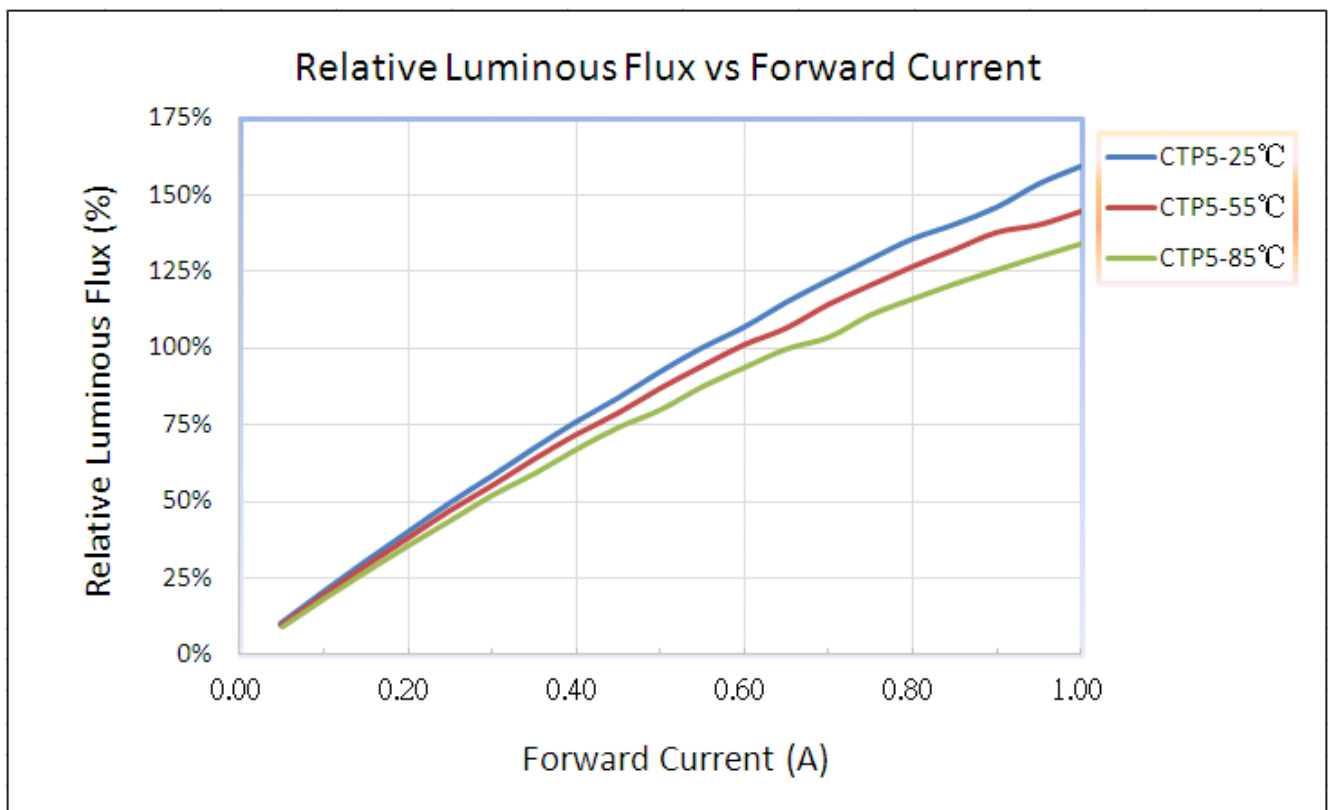

<Figure4 Relative Luminous Flux vs. Forward Current>

Official Product	HT Part No HT- CTP5	Your Part No.		Data Sheet No.
Tentative Product	*****	*****		
Specifications are subject to changes for improvement without advance notice. Proprietary data, drawings, and company confidential all rights reserved.		Aug-04, 2017	Version of 1.2	Page 13/21

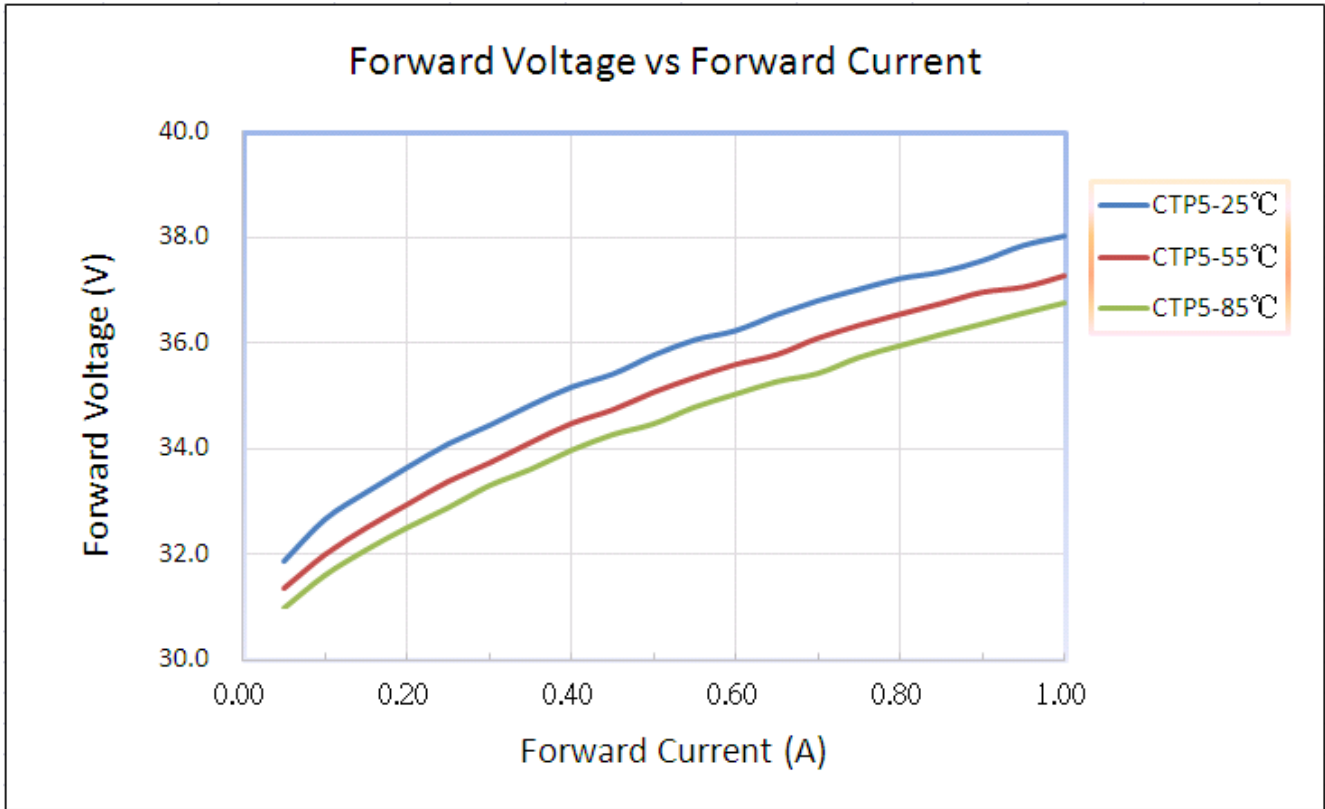

<Figure5 Forward Voltage vs. Forward Current>

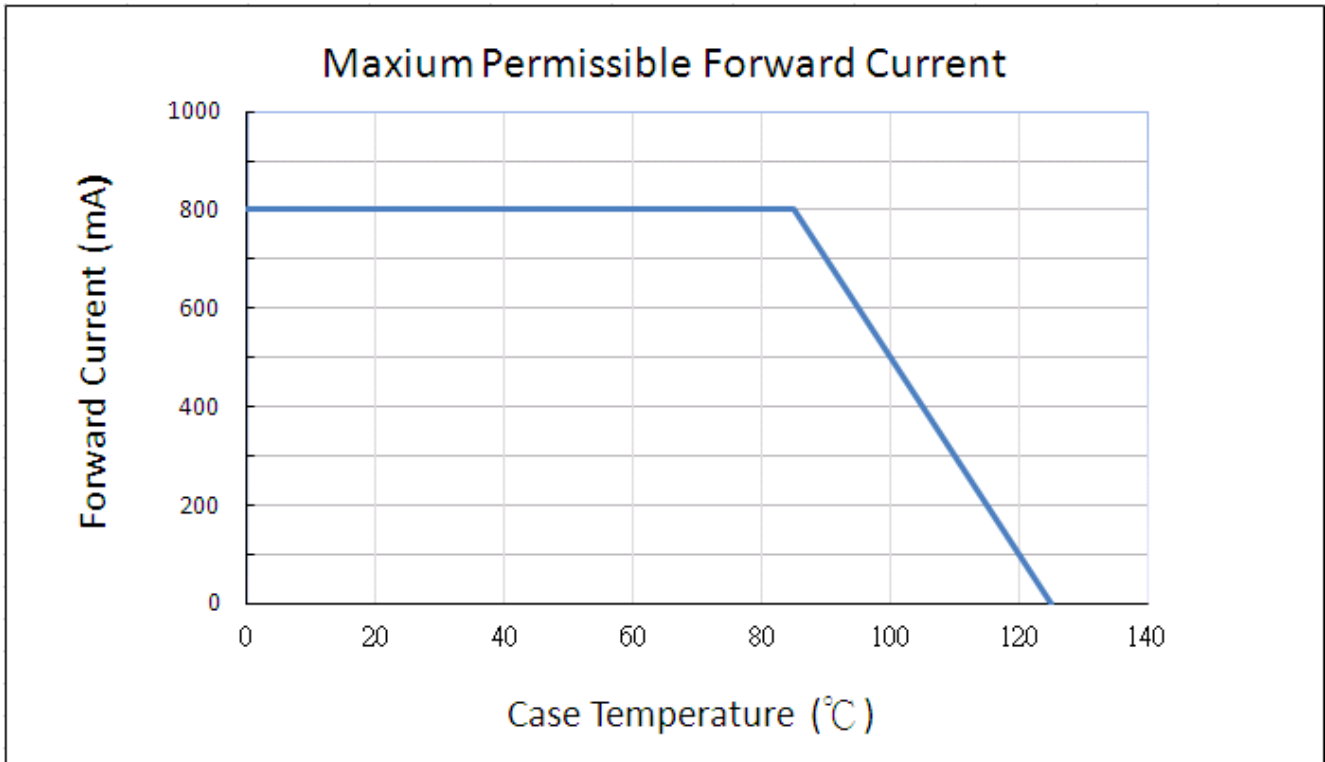

<Figure6 Forward Current vs. Case Temperature>

Official Product	HT Part No HT- CTP5	Your Part No.		Data Sheet No.
Tentative Product	*****	*****		
Specifications are subject to changes for improvement without advance notice. Proprietary data, drawings, and company confidential all rights reserved.		Aug-04, 2017	Version of 1.2	Page 14/21

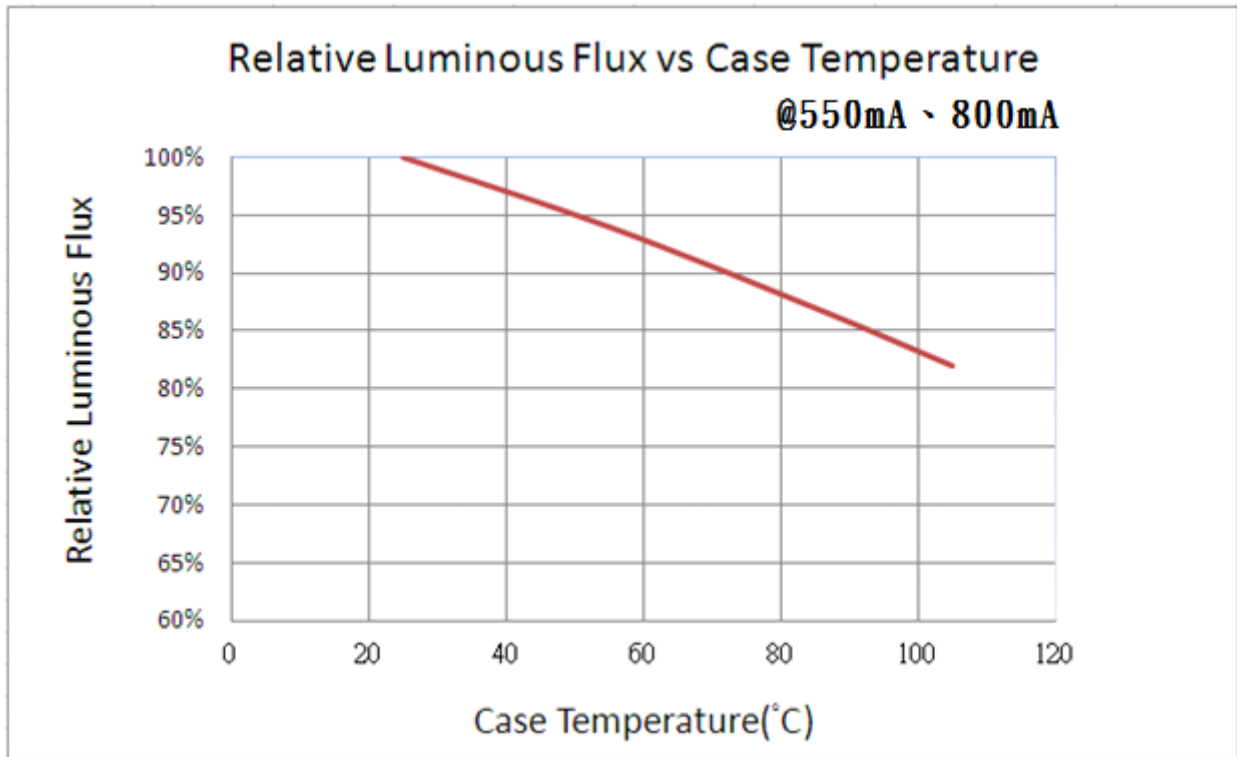

<Figure7 Relative Luminous Fluxvs. Case Temperature>

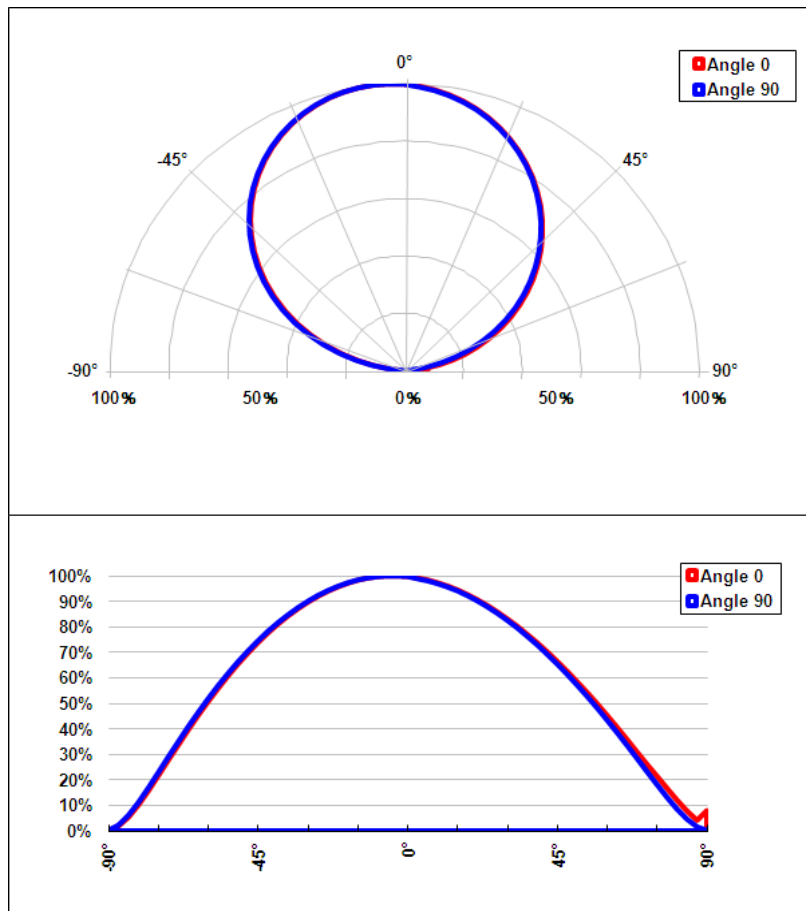

<Figure8 Photometric>

Official Product	HT Part No HT- CTP5	Your Part No.		Data Sheet No.
Tentative Product	*****	*****		
Specifications are subject to changes for improvement without advance notice. Proprietary data, drawings, and company confidential all rights reserved.		Aug-04, 2017	Version of 1.2	Page 15/21

Precaution for Use

1. The chips should not be used directly in any type of fluid such as water, oil, organic solvent, etc.
2. When the LEDs are illuminating, the maximum ambient temperature should be first considered before operation.
3. LEDs must be stored in a clean environment. A sealed container with a nitrogen atmosphere is necessary if the storage period is over 3 months after shipping.
4. The LEDs must be used within 72 hrs after unpacked. Unused products must be repacked in an anti-electrostatic package, folded to close any opening and then stored in a dry and cool space.
5. The appearance and specifications of the products may be modified for improvement without further notice.
6. The LEDs are sensitive to the static electricity and surge. It is strongly recommended to use a grounded wrist band and anti-electrostatic glove when handling the LEDs. If a voltage over the absolute maximum rating is applied to LEDs, it will damage LEDs. Damaged LEDs will show some abnormal characteristics such as remarkable increase of leak current, lower turn-on voltage and getting unlit at low current.

Official Product	HT Part No HT- CTP5	Your Part No.		Data Sheet No.
Tentative Product	*****	*****		
Specifications are subject to changes for improvement without advance notice. Proprietary data, drawings, and company confidential all rights reserved.		Aug-04, 2017	Version of 1.2	Page 16/21

Label spec.

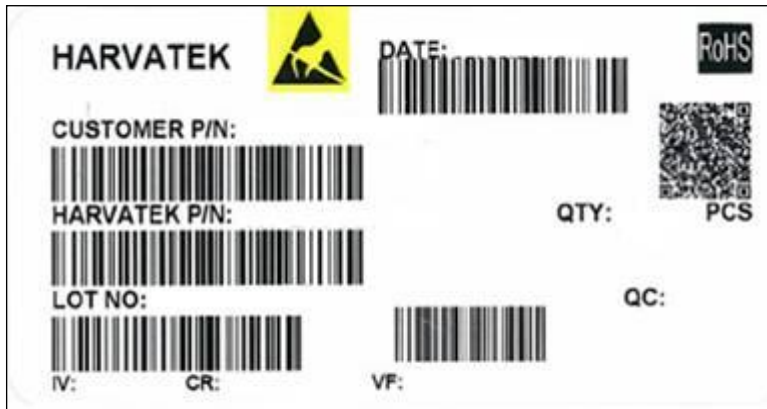

Customer P/N: To Be Defined

Harvatek P/N

Small Label on each tray

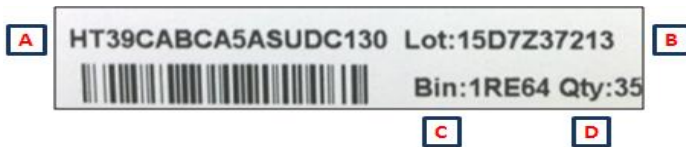

A	B	C	D
HT Part No.#	Lot No.	Bin Code	Qty

Lot No.

1	2	3	4	5	6	7	8	9	10
E	1	A	1	A	2	2	L	1	2
Code 1 2		Code 3	Code 4	Code 5	Code 6	Code 7	Code 8	Code 9	Code 10
		Mfg. Year	Mfg. Month	Mfg. Date	Consecutive number		Special code		
Internal Tracing Code		2010-A 2011-B 2012-C 2013-D . .	1:Jan. 2:Feb. ... A:Oct. B:Nov. C:Dec.	1:A 2:B 3:C ... 26:Z 27:7 28:8 29:9 30:3 31:4	01~ZZ		000~ZZZ		

Official Product	HT Part No HT- CTP5	Your Part No.		Data Sheet No.
Tentative Product	*****	*****		
Specifications are subject to changes for improvement without advance notice. Proprietary data, drawings, and company confidential all rights reserved.		Aug-04, 2017	Version of 1.2	Page 17/21

Packing Model

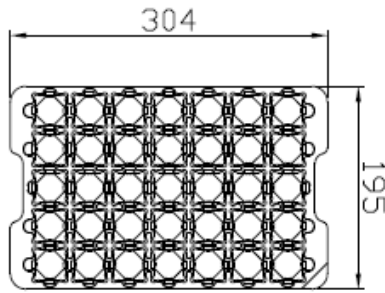

<Figure 9 Tray packaging dimension>

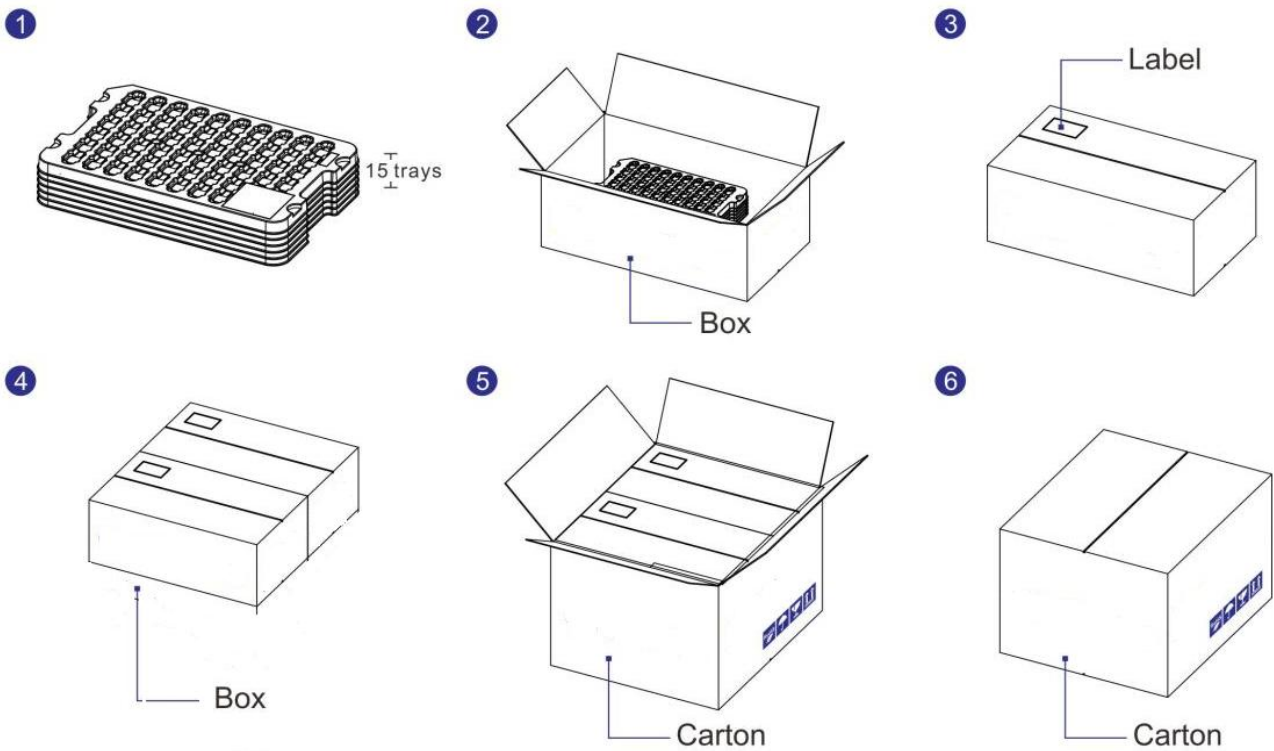

<Figure 10 Packaging steps>

Notes:

1. All dimensions are in mm.
2. Normally, the maximum trays of a box are around 15 depend on products.
3. There are 2 inner boxes in a carton.

Official Product	HT Part No HT- CTP5	Your Part No.		Data Sheet No.
Tentative Product	*****	*****		
Specifications are subject to changes for improvement without advance notice. Proprietary data, drawings, and company confidential all rights reserved.		Aug-04, 2017	Version of 1.2	Page 18/21

Handling of Silicone Resin LEDs

Handling Indications

During processing, mechanical stress on the surface should be minimized as much as possible.

Sharp objects of all types should not be used to pierce the sealing compound.



Figure 11

In general, LEDs should only be handled from the side. By the way, this also applies to LEDs without a silicone sealant, since the surface can also become scratched.

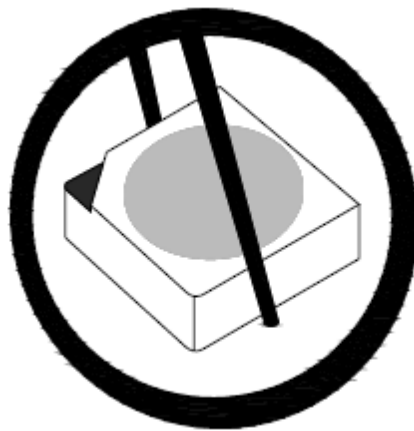

Figure 12

When populating boards in SMT production, there are basically no restrictions regarding the form of the pick and place nozzle, except that mechanical pressure on the surface of the resin must be prevented.

This is assured by choosing a pick and place nozzle which is larger than LEDs reflector area.

Official Product	HT Part No HT- CTP5	Your Part No.		Data Sheet No.
Tentative Product	*****	*****		
Specifications are subject to changes for improvement without advance notice. Proprietary data, drawings, and company confidential all rights reserved.		Aug-04, 2017	Version of 1.2	Page 19/21

Reflow Soldering

Recommend soldering paste specifications:

1. Operating temp.: Above 220 °C ,60 sec.
2. Peak temp.:260 °CMax.,10sec Max.
3. Reflow soldering should not be done more than two times.
4. Never attempt next process until the component is cooled down to room temperature after reflow.
5. The recommended reflow soldering profile (measured on the surface of the LED terminal) is as following:

Lead-free Solder Profile

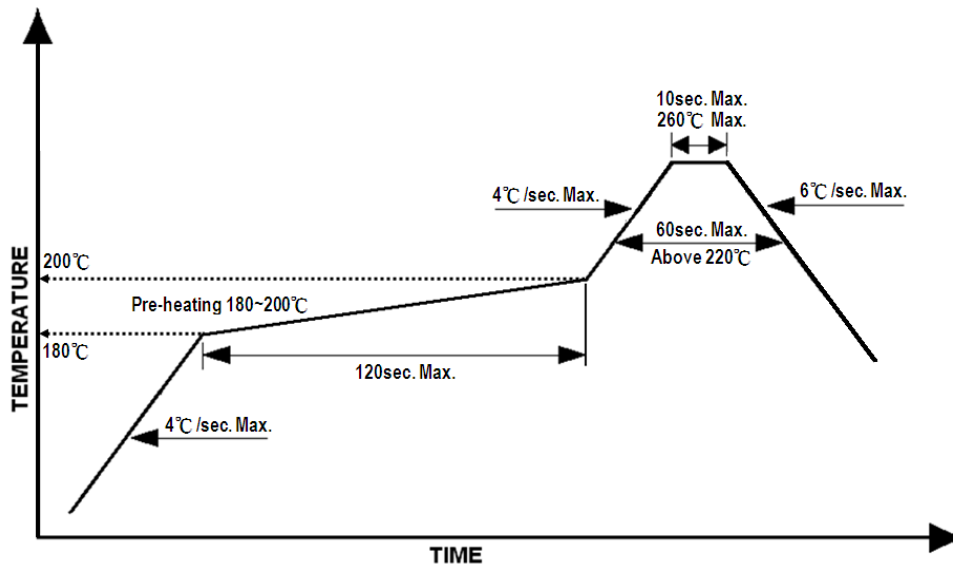

Official Product	HT Part No HT- CTP5	Your Part No.		Data Sheet No.
Tentative Product	*****	*****		
Specifications are subject to changes for improvement without advance notice. Proprietary data, drawings, and company confidential all rights reserved.		Aug-04, 2017	Version of 1.2	Page 20/21

Reworking

- Rework should be completed within 5 seconds under 260 °C.
- Manual soldering (not recommended):
Soldering tin material: tin 6/4 alloy or contained Ag.
To prevent cracking, bake before manual soldering.
Temperature of iron tip: 300 °C±5 °C.
Soldering duration: 3sec±1sec.

Cleaning

Following are cleaning procedures after soldering:

- An alcohol-based solvent such as isopropyl alcohol (IPA) is recommended.
- Temperature x Time should be 50°C x 30sec. or <30°C x 3min
- Ultrasonic cleaning: < 15W/ bath; bath volume ≤ 1liter
- Curing: 100 °C max, <3min

Cautions of Pick and Place

- Avoid stress on the resin at elevated temperature.
- Avoid rubbing or scraping the resin by any object.
- Electric-static may cause damage to the component. Please ensure that the equipment is properly grounded. Use of an ionizer fan is recommended.

Storage

- It is recommended that products be stored under the following conditions:
Humidity: 60%R.H. maximum
Temperature: 5°C ~ 30°C (41°F ~ 86°F)
- Shelf life in sealed bag: 6 months at <40°C and <90%R.H.
- After opening the bag, devices that will be subjected to soldering or equivalent processing should be used within one year at a condition of ≤30°C / 60%R.H.

Revise History

Rev.	Descriptions	Date	Page
1.0	New	05/27/2015	-
1.1	Add 30W@800mA	01/25/2016	
1.2	Datasheet update	08/04/2017	

Official Product	HT Part No HT- CTP5	Your Part No.		Data Sheet No.
Tentative Product	*****	*****		
Specifications are subject to changes for improvement without advance notice. Proprietary data, drawings, and company confidential all rights reserved.		Aug-04, 2017	Version of 1.2	Page 21/21