



## IS281GB ( Compact Range )

### DESCRIPTION

The IS281 is an optically coupled isolator consisting of an infrared light emitting diode and an NPN silicon photo transistor. It belongs to Isocom's Compact range of opto-couplers. It has been specially selected to give a higher guaranteed CTR

### FEATURES

- Low profile package ( half pitch )
- AC Isolation test voltage 3750V<sub>RMS</sub>
- Low coupling capacitance typically 0.3pF
- CTR > 100%
- Wide temperature range
- Lead free

### APPLICATIONS

- Power Supply Feedback Voltage/Current
- Industrial system controllers
- Measuring instruments
- Signal transmission between systems of different potentials and impedance

### ORDER INFORMATION

- Available in Tape and Reel with 3000 pieces per reel

### MARKING INFORMATION

Please note that the device will be marked with the generic part number "THP1" the date code will also be marked on the device.

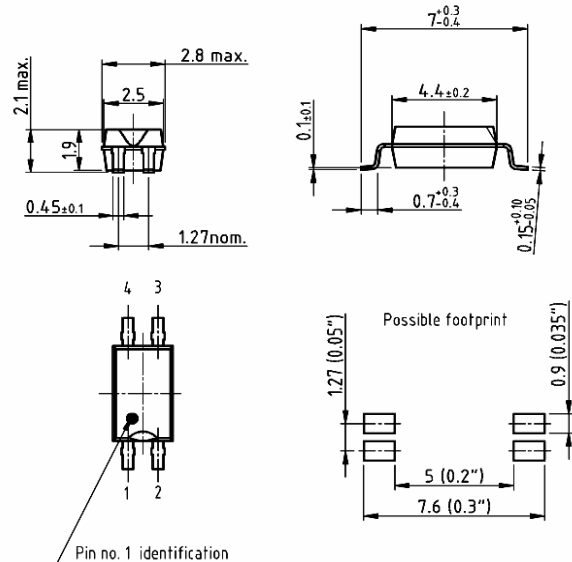

16283

Technical drawings according to DIN specifications

### ABSOLUTE MAXIMUM RATINGS

#### Input Diode

Forward Current	60mA
Reverse Voltage	6V
Power dissipation	100mW

#### Output Transistor

Collector to Emitter Voltage	70V
Emitter to Collector Voltage	7V
Collector Current	50mA
Power Dissipation	100mW

#### Total Package

Isolation test Voltage	3750V <sub>RMS</sub>
Operating Temperature	-40 to 100 C
Storage Temperature	-40 to 100 C

#### ISOCOM COMPONENTS 2004 LTD

Unit 25B, Park View Road West, Park View Industrial Estate  
Hartlepool, Cleveland, TS25 1UD, United Kingdom  
Tel: +44 (0)1429 863 609 Fax : +44 (0)1429 863 581  
e-mail: sales@isocom.co.uk  
<http://www.isocom.com>

#### ISOCOM COMPONENTS ASIA LTD

Hong Kong Office, 1712-1713  
Laurels Industrial Centre, 32 Tai Yau Street,  
San Po Kong, Kowloon, Hong Kong.  
Tel: +852 2995 9217 Fax : +852 8161 6292  
e-mail sales@isocom.com.hk



## IS281GB ( Compact Range )

### ELECTRICAL CHARACTERISTICS

Ambient Temperature = 25°C unless otherwise specified

#### INPUT

Parameter	Symbol	Test Condition	Min	Typ.	Max	Unit
Forward Voltage	$V_F$	$I_F = 50\text{mA}$		1.25	1.25	V
Reverse Leakage	$I_R$	$V_R = 6\text{V}$			10	$\mu\text{A}$
Junction Capacitance	$C_j$	$V_R = 0\text{V}, f = 1 \text{ MHz}$		50		pF

#### OUTPUT

Parameter	Symbol	Test Condition	Min	Typ.	Max	Unit
Collector—Emitter breakdown Voltage	$BV_{CEO}$	$I_C = 100\mu\text{A}$	70			V
Emitter—Collector breakdown Voltage	$BV_{ECO}$	$I_E = 100\mu\text{A}$	7			V
Collector dark Current	$I_{CEO}$	$V_{CE} = 20\text{V}, I_F = 0\text{mA}$			100	nA

#### COUPLED

Parameter	Symbol	Test Condition	Min	Typ.	Max	Unit
Current transfer ratio	CTR	$I_F = 5\text{mA}, V_{CE} = 5\text{V}$	100		600	%
Collector—Emitter saturation Voltage	$V_{CEsat}$	$I_F = 10\text{mA}, I_C = 1\text{mA}$			0.3	V
Input to output isolation Voltage	$V_{ISO}$	See note 1	3750			$V_{RMS}$
Output rise time	$t_r$	$V_S = 5\text{V}, I_C = 2\text{mA}, R_L = 100\Omega$		3.0		$\mu\text{S}$
Output fall time	$t_f$	$V_S = 5\text{V}, I_C = 2\text{mA}, R_L = 100\Omega$		3.0		$\mu\text{S}$
Cut off frequency	$f_c$	$I_F = 10\text{mA}, V_{CE} = 5\text{V}, R_L = 100\Omega$		100		kHz
Coupling Capacitance	$C_k$	$f = 1 \text{ MHz}$		0.3		pF

Note 1 Measured with input leads shorted together and output leads shorted together



## IS281GB( Compact Range )

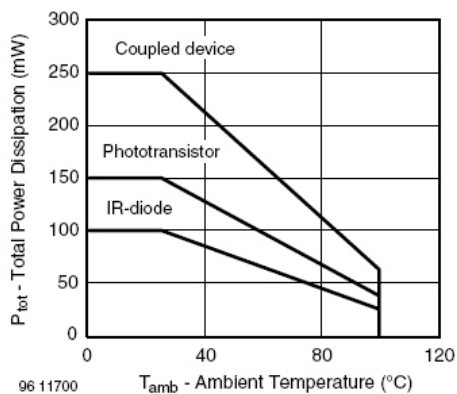

Figure 4. Total Power Dissipation vs. Ambient Temperature

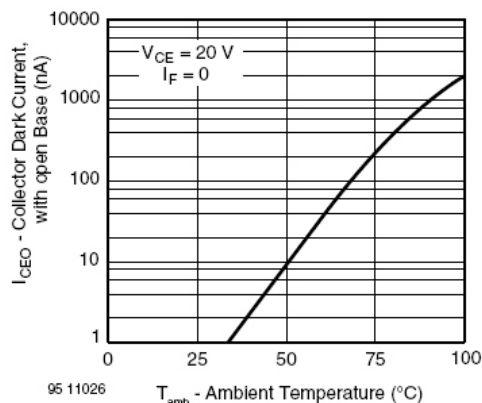

Figure 7. Collector Dark Current vs. Ambient Temperature

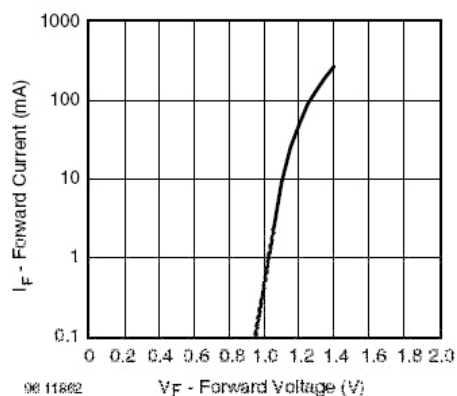

Figure 5. Forward Current vs. Forward Voltage

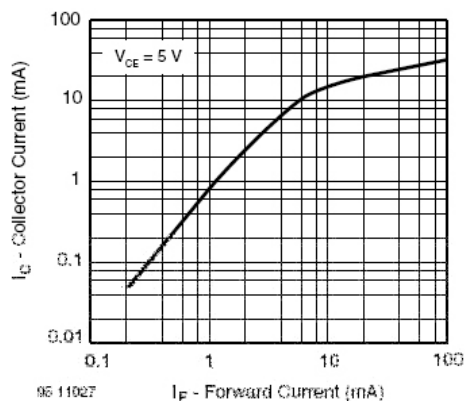

Figure 8. Collector Current vs. Forward Current

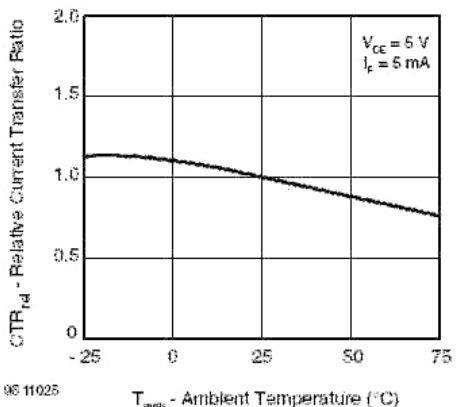

Figure 6. Relative Current Transfer Ratio vs. Ambient Temperature

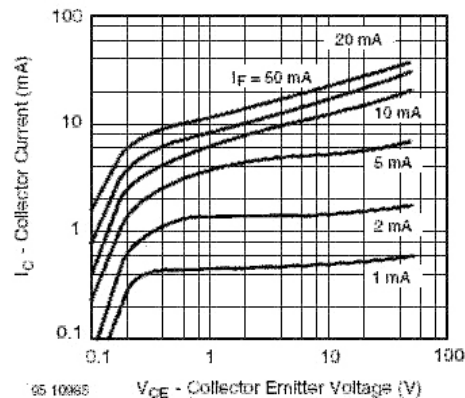

Figure 9. Collector Current vs. Collector Emitter Voltage



## IS281GB ( Compact Range )

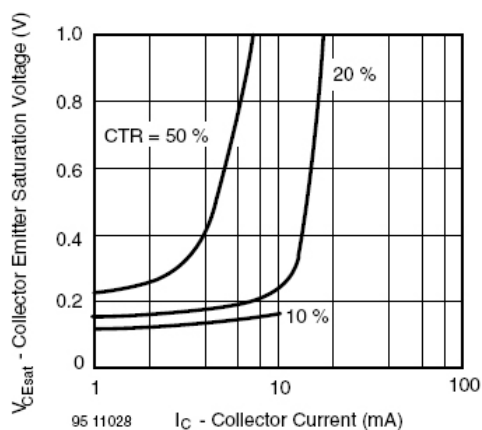

Figure 10. Collector Emitter Saturation Voltage vs. Collector Current

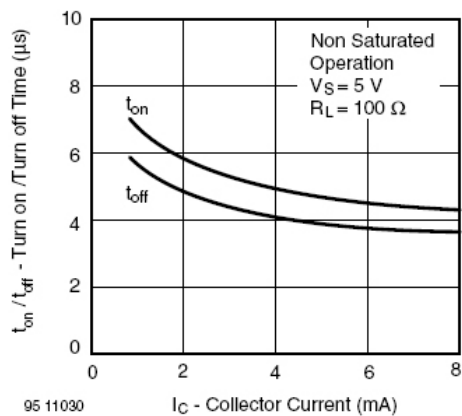

Figure 13. Turn on/off Time vs. Collector Current

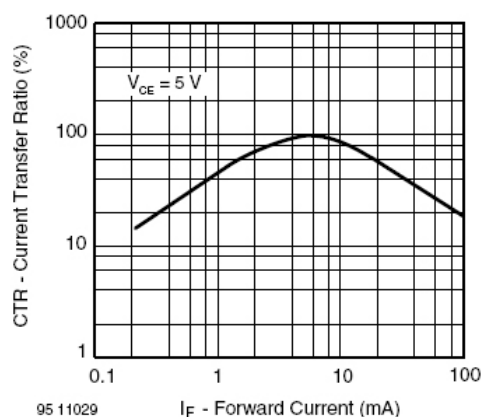

Figure 11. Current Transfer Ratio vs. Forward Current

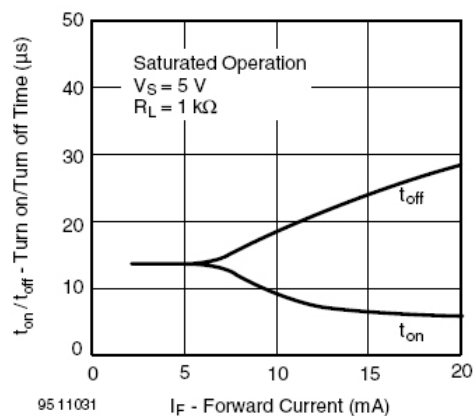

Figure 12. Turn on/off Time vs. Forward Current