

IS849



ISOCOM
COMPONENTS

**OPTICALLY COUPLED ISOLATOR
TRANSISTOR OUTPUT**



SCHEMATIC

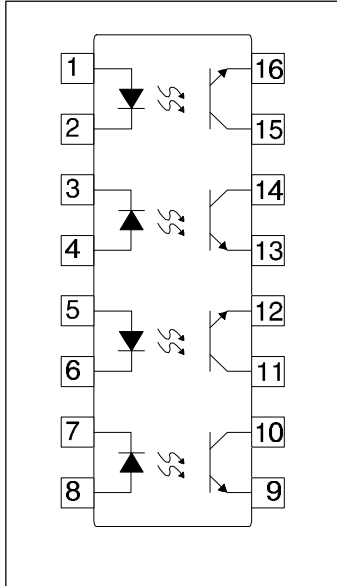

PACKAGE DIMENSIONS INCHES (MM)

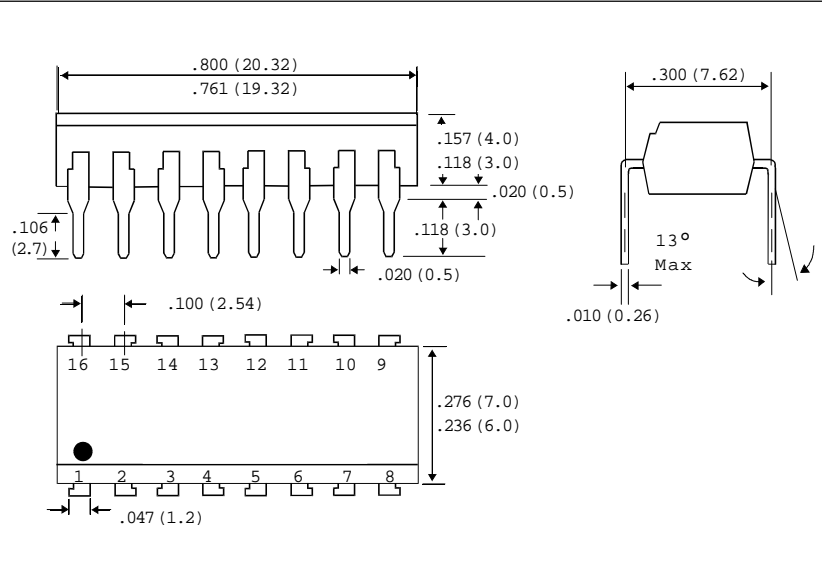

DESCRIPTION

The IS849 is an optically coupled isolator consisting of Gallium Arsenide infrared emitting diodes and NPN silicon phototransistors mounted in a standard 16-pin dual-in-line package with four channels per unit.

FEATURES

- Also available in single, dual package

ABSOLUTE MAXIMUM RATINGS (25°C unless otherwise noted)

Storage Temperature	-55°C to +125°C
Operating Temperature	-30°C to +100°C
Lead Soldering Temperature (2mm from case for 10 seconds)	260°C
Input-to-Output Isolation Voltage	5000V _{RMS}

INPUT DIODE

Forward D.C. Current	50mA
Reverse D.C. Voltage	6V
Peak Forward Current (p.w. ≤ 100µs, duty ratio 0.001)	1A
Power Dissipation (derate linearly 1.33mW/°C above 25°C)	70mW

OUTPUT TRANSISTOR

Collector-emitter Voltage BV _{CEO}	35V
Power Dissipation (derate linearly 1.50mW/°C above 25°C)	150mW

PACKAGE

Total Power Dissipation	170mW
-------------------------	-------

ISOCOM COMPONENTS LTD
Unit 25B, Park View Road West,
Park View Industrial Estate, Brenda Road
Hartlepool, Cleveland, TS25 1YD
Tel: (0429) 863609 Fax :(0429) 863581

ELECTRICAL CHARACTERISTICS (25°C unless otherwise noted)

PARAMETER		MIN	TYP	MAX	UNITS	TEST CONDITION
Input	Forward Voltage (V_F)		1.2	1.4	Volt	$I_F = 20 \text{ mA}$
	Reverse Current (I_R)			10	μA	$V_R = 4 \text{ V}$
Output	Collector-emitter Voltage (BV_{CEO})	35			Volt	$I_C = 1 \text{ mA}$
	Emitter-collector Voltage (BV_{ECO})	7	9		Volt	$I_E = 0.1 \text{ mA}$
	Collector-emitter Dark Current (I_{CBO})			100	nA	$V_{CE} = 20 \text{ V}$
Coupled	DC Current Transfer Ratio (CTR)	50		400	%	$I_F = 5 \text{ mA}, V_{CE} = 5 \text{ V}$
	Collector-emitter Saturation Voltage $V_{CE}(\text{Sat})$			0.2	Volt	$I_F = 20 \text{ mA}, I_C = 1 \text{ mA}$
	Floating Capacitance (C_F)		0.6	1	μf	$V = 0, f = 1 \text{ Mhz}$
	Input-to-Output Isolation Resistance R_{iso}	5×10^{10}	10^{11}		Ω	$V_{IO} = 500 \text{ V}$ (see note 1)
	Input to Output Isolation Voltage	5000			V_{RMS}	(note 1)
	Response Time Rise (t_r)			15	μs	$I_C = 2 \text{ mA}, V_{CE} = 2 \text{ V}$ $R_L = 100 \Omega$
Response Time Fall (t_f)			15	μs		

Note 1. Measured with input leads shorted together and output leads shorted together.

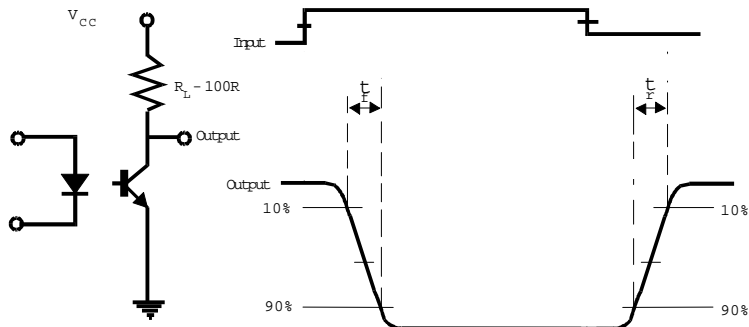

FIG 1