



HIGH VOLTAGE DARLINGTON OUTPUT OPTICALLY COUPLED ISOLATOR

APPROVALS

- UL recognised, File No. E91231
Package Code " FF "

'X' SPECIFICATION APPROVALS

- VDE 0884 in 3 available lead form : -
 - STD
 - G form
 - SMD approved to CECC 00802

DESCRIPTION

The IS627 is an optically coupled isolator consisting of infrared light emitting diode and a high voltage NPN silicon photo darlington which has an integral base-emitter resistor to optimise switching speed and elevated temperature characteristics in a standard 4 pin dual in line plastic package.

FEATURES

- Options :-
 - 10mm lead spread - add G after part no.
 - Surface mount - add SM after part no.
 - Tape&reel - add SMT&R after part no.
- High Isolation Voltage ($5.3kV_{RMS}, 7.5kV_{PK}$)
- High Current Transfer Ratio (1000% min)
- High BV_{CEO} (300V min.)
- Low input current $1mA I_F$

APPLICATIONS

- Modems
- Copiers, facsimiles
- Numerical control machines
- Signal transmission between systems of different potentials and impedances

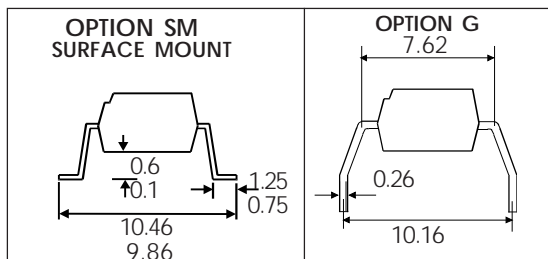

Dimensions in mm

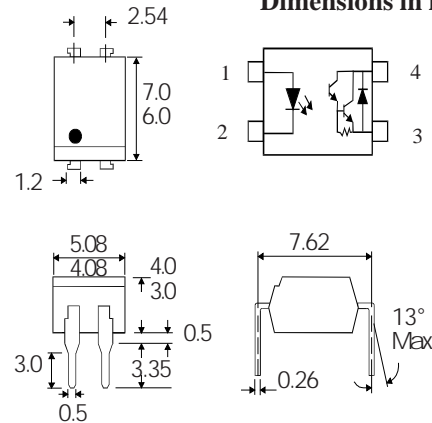

ABSOLUTE MAXIMUM RATINGS (25°C unless otherwise specified)

Storage Temperature _____ -55°C to +125°C
 Operating Temperature _____ -30°C to +100°C
 Lead Soldering Temperature
 (1/16 inch (1.6mm) from case for 10 secs) 260°C

INPUT DIODE

Forward Current _____ 50mA
 Reverse Voltage _____ 6V
 Power Dissipation _____ 70mW

OUTPUT TRANSISTOR

Collector-emitter Voltage BV_{CEO} _____ 300V
 Emitter-collector Voltage BV_{ECO} _____ 0.1V
 Collector Current I_C _____ 150mA
 Power Dissipation _____ 150mW

POWER DISSIPATION

Total Power Dissipation _____ 200mW

ISOCOM COMPONENTS LTD

Unit 25B, Park View Road West,
 Park View Industrial Estate, Brenda Road
 Hartlepool, Cleveland, TS25 1YD
 Tel: (01429) 863609 Fax :(01429) 863581

ELECTRICAL CHARACTERISTICS ($T_A = 25^\circ\text{C}$ Unless otherwise noted)

PARAMETER		MIN	TYP	MAX	UNITS	TEST CONDITION
Input	Forward Voltage (V_F)		1.2	1.4	V	$I_F = 10\text{mA}$
	Reverse Current (I_R)			10	μA	$V_R = 4\text{V}$
Output	Collector-emitter Breakdown (BV_{CEO})	300			V	$I_C = 0.1\text{mA}$
	Emitter-collector Breakdown (BV_{ECO})	0.1			V	$I_E = 10\mu\text{A}$
	Collector-emitter Dark Current (I_{CEO})		10	200	nA	$V_{CE} = 200\text{V}$
Coupled	Current Transfer Ratio (CTR)	1000	4000	15000	%	$1\text{mA} I_F, 2\text{V} V_{CE}$
	Collector-emitter Saturation Voltage $V_{CE(SAT)}$			1.2	V	$20\text{mA} I_F, 100\text{mA} I_C$
	Input to Output Isolation Voltage V_{ISO}	5300			V_{RMS}	See note 1
	Input-output Isolation Resistance R_{ISO}	7500			V_{PK}	See note 1
		5×10^{10}			Ω	$V_{IO} = 500\text{V}$ (note 1)
	Input-output Capacitance	Cf		1	pF	$V = 0, f = 1\text{MHz}$
	Cut-off Frequency	fc		7	kHz	$V_{CE} = 2\text{V}, I_C = 20\text{mA}, R_L = 100\Omega, -3\text{dB}$
Output Rise Time	tr		100	μs	$V_{CE} = 2\text{V}, I_C = 20\text{mA}, R_L = 100\Omega$	
Output Fall Time	tf		20	μs		

Note 1 Measured with input leads shorted together and output leads shorted together.

Note 2 Special Selections are available on request. Please consult the factory.

FIGURE 1

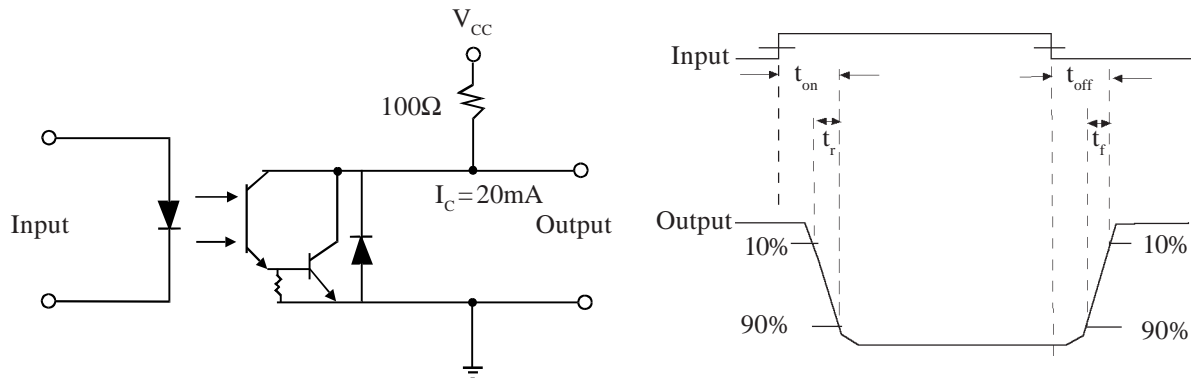

Collector Power Dissipation vs. Ambient Temperature

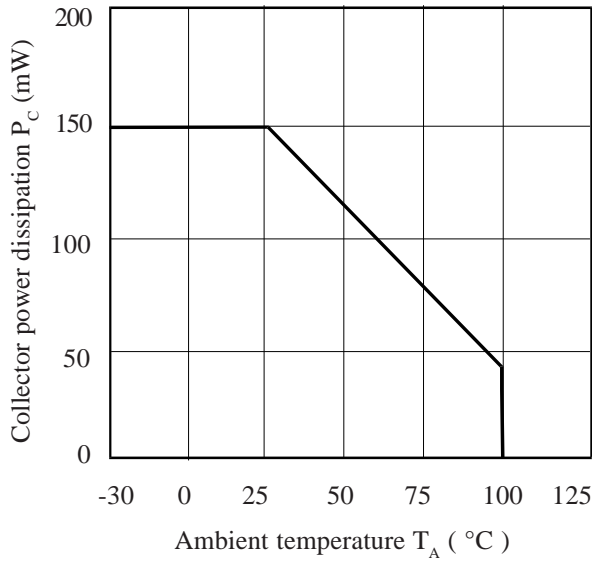

Collector Current vs. Collector-emitter Voltage

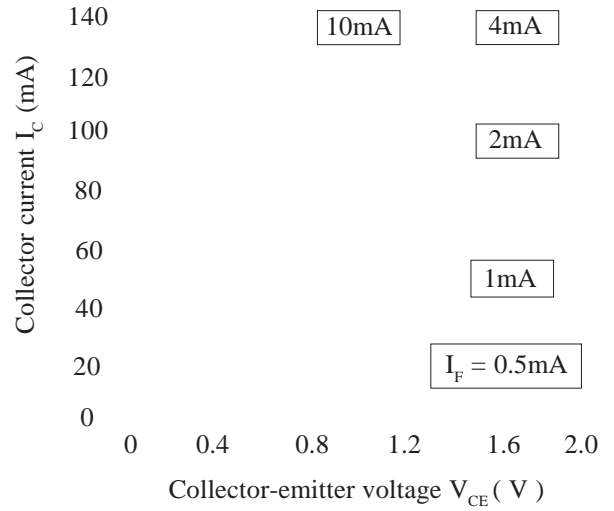

Forward Current vs. Ambient Temperature

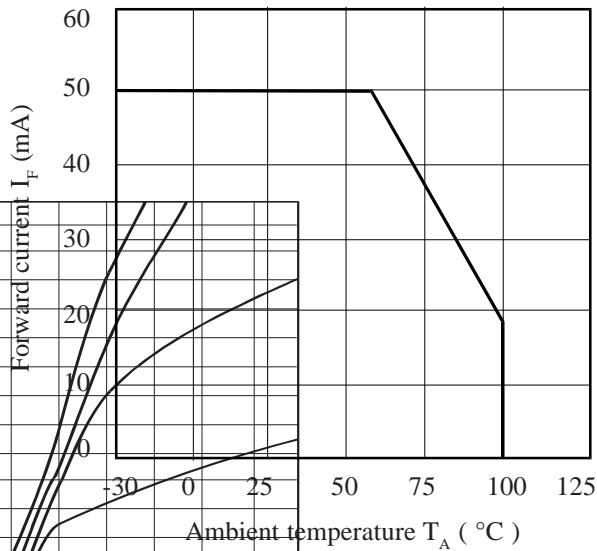

Relative Current Transfer Ratio vs. Ambient Temperature

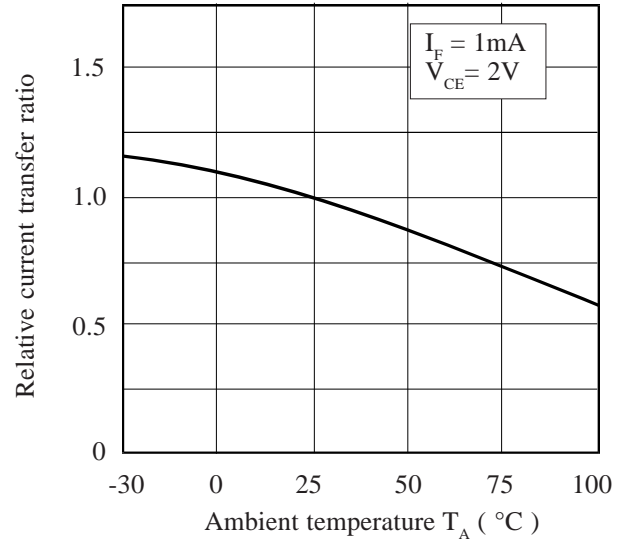

Collector-emitter Saturation Voltage vs. Ambient Temperature

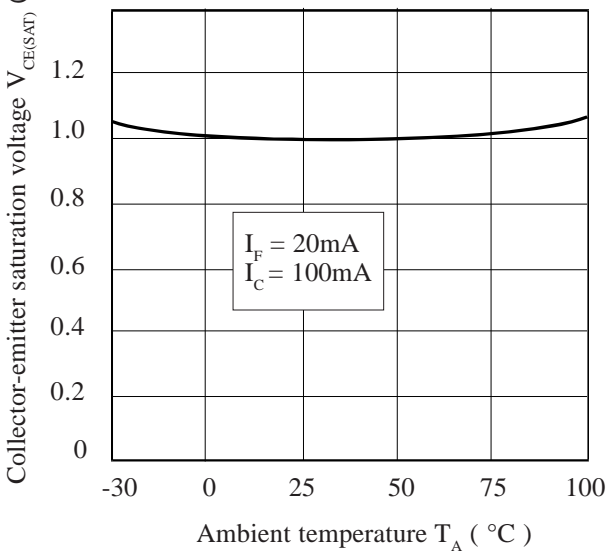

Collector Dark Current vs. Ambient Temperature

