

# SOLID TANTALUM CHIP CAPACITORS

## T495 SERIES—Low ESR, Surge Robust



### FEATURES

- Designed for very low ESR
- High ripple current capability
- High surge current capability
- 100% accelerated steady-state aging
- 100% Surge Current test
- Meets or Exceeds EIA Standard 535BAAC
- Available tested per DSCC Dwg. 95158
- New Extended Values for Low ESR
- Low Equivalent Series Inductance (<2.5nH ESL)
- Precision-molded, laser-marked case
- Symmetrical, compliant terminations
- Taped and reeled per EIA 481-1
- RoHS Compliant & Leadfree Terminations (see www.kemet.com for lead transition)

### OUTLINE DRAWING

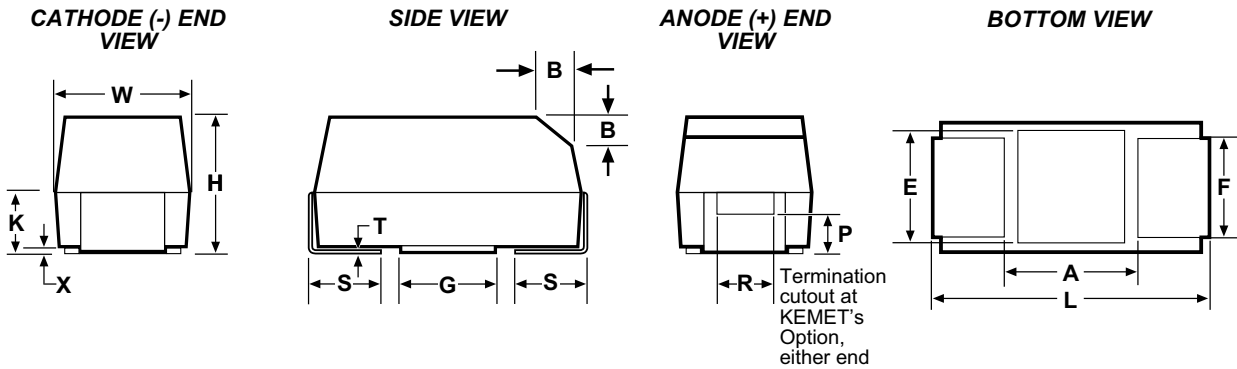

### STANDARD T495 DIMENSIONS

Millimeters (Inches)

CASE SIZE		COMPONENT													
KEMA	EIA	L	W	H	K ± 0.20 ± (.008)	F ± 0.1 ± (.004)	S ± 0.3 ± (.012)	B ± 0.15 (Ref) ± (.006)	X (Ref)	P (Ref)	R (Ref)	T (Ref)	A (Min)	G (Ref)	E (Ref)
B	3528-21	3.5 ± 0.2 (.138 ± .008)	2.8 ± 0.2 (.110 ± .008)	1.9 ± 0.2 (.075 ± .008)	1.1 (.043)	2.2 (.087)	0.8 (.031)	0.4 (.016)	0.10 ± 0.10 (.004 ± .004)	0.5 (.020)	1.0 (.039)	0.13 (.005)	1.1 (.043)	1.8 (.071)	2.2 (.087)
C	6032-28	6.0 ± 0.3 (.236 ± .012)	3.2 ± 0.3 (.126 ± .012)	2.5 ± 0.3 (.098 ± .012)	1.4 (.055)	2.2 (.087)	1.3 (.051)	0.5 (.020)	0.10 ± 0.10 (.004 ± .004)	0.9 (.035)	1.0 (.039)	0.13 (.005)	2.5 (.098)	2.8 (.110)	2.4 (.094)
D	7343-31	7.3 ± 0.3 (.287 ± .012)	4.3 ± 0.3 (.169 ± .012)	2.8 ± 0.3 (.110 ± .012)	1.5 (.059)	2.4 (.094)	1.3 (.051)	0.5 (.020)	0.10 ± 0.10 (.004 ± .004)	0.9 (.035)	1.0 (.039)	0.13 (.005)	3.8 (.150)	3.5 (.138)	3.5 (.138)
X	7343-43	7.3 ± 0.3 (.287 ± .012)	4.3 ± 0.3 (.169 ± .012)	4.0 ± 0.3 (.157 ± .012)	2.3 (.091)	2.4 (.094)	1.3 (.051)	0.5 (.020)	0.10 ± 0.10 (.004 ± .004)	1.7 (.067)	1.0 (.039)	0.13 (.005)	3.8 (.150)	3.5* (.138)	3.5* (.138)

- Notes: 1. Metric dimensions govern.  
 2. (Ref) - Dimensions provided for reference only.  
 \* Round Glue Pad: 2.9 ± 0.1mm (0.114" ± 0.004") in diameter at KEMET's option.

### LOW PROFILE T495 DIMENSIONS

Millimeters (Inches)

CASE SIZE		COMPONENT										
KEMET	EIA	L	W	H Max.	K Min.	F ± 0.1	S ± 0.3	X (Ref)	T (Ref)	A (Min)	G (Ref)	E (Ref)
T	3528-12	3.5 ± 0.2 (.138 ± .008)	2.8 ± 0.2 (.110 ± .008)	1.2 (.047)	0.3 (.012)	2.2 (.087)	0.8 (.031)	0.05 (.002)	0.13 (.005)	1.1 (.043)	1.8 (.071)	2.2 (.087)
V	7343-20	7.3 ± 0.3 (.287 ± .012)	4.3 ± 0.3 (.169 ± .012)	2.0 (0.079)	0.9 (.035)	2.4 (.094)	1.3 (.051)	0.05 (.002)	0.13 (.005)	3.8 (.150)	3.5 (.138)	3.5 (.138)

- Notes: 1. Metric dimensions govern.  
 2. (Ref) - Dimensions provided for reference only.  
 3. No dimensions provided for B, P or R because low profile cases do not have a bevel or a notch.

Solid Tantalum Surface Mount



# SOLID TANTALUM CHIP CAPACITORS

T495 SERIES—Low ESR, Surge Robust

## T495 RATINGS & PART NUMBER REFERENCE

Capacitance $\mu$ F	Case Size	KEMET Part Number	DSCC Dwg. No. 95158 Part Number	DC Leakage $\mu$ A @ 25°C Max	DF% @ 25°C 120 Hz Max	ESR mW @ 25°C 100 kHz Max	Ripple Current mA rms at 25°C, 100 kHz Max		
							25°C	85°C	125°C
<b>4 Volt Rating @ +85°C (2.7 Volt Rating at +125°C)</b>									
150.0	B	T495B157M004AS		6.0	12.0	90	307	277	123
330.0	*C	T495C337(1)004AS		13.2	12.0	700	396	357	159
1000.0	*X	T495X108(1)004AS		40.0	12.0	70	1535	1381	614
<b>6/6.3 Volt Rating @ +85°C (4 Volt Rating at +125°C)</b>									
68.0	D	T495D686(1)006AS		3.3	4.0	175	926	833	370
68.0	D	T495D686(1)006AS4095	95158-01(1)(2)	3.3	4.0	175	926	833	370
100.0	*C	T495C107(1)006AS		6.0	8.0	150	856	770	342
100.0	*V	T495V107(1)006AS		6.0	8.0	150	913	822	365
100.0	*B	T495B107M006AS		6.3	15.0	700	348	313	139
150.0	C	T495C157(1)006AS		9.0	8.0	200	742	668	297
150.0	X	T495X157(1)006AS		7.2	6.0	100	1285	1156	514
150.0	*X	T495X157(1)006AS4095	95158-02(1)(2)	7.2	6.0	125	1150	1040	460
220.0	*C	T495C227(1)006AS		13.9	10.0	225	700	600	300
220.0	*D	T495D227(1)006AS		13.2	8.0	100	1225	1102	490
220.0	*D	T495D227(1)006AS4095	95158-25(1)(2)	13.2	8.0	100	1225	1102	490
220.0	*X	T495X227(1)006AS		13.2	8.0	100	1285	1156	514
220.0	*X	T495X227(1)006AS4095	95158-03(1)(2)	13.2	8.0	100	1285	1156	514
330.0	*D	T495D337(1)006AS		20.8	8.0	100	1225	1102	490
330.0	*X	T495X337(1)006AS		19.8	8.0	100	1285	1156	514
330.0	*X	T495X337(1)006AS4823		19.8	8.0	65	1593	1434	637
470.0	*D	T495D477(1)006AS		29.6	12.0	125	1095	986	438
470.0	*X	T495X477(1)006AS		28.2	10.0	65	1593	1434	637
470.0	*X	T495X477(1)006AS4823		28.2	10.0	50	1816	1634	726
<b>10 Volt Rating @ +85°C (7 Volt Rating at +125°C)</b>									
22.0	C	T495C226(1)010AS		2.2	6.0	345	565	508	226
47.0	D	T495D476(1)010AS		3.8	4.0	200	866	780	346
47.0	D	T495D476(1)010AS4095	95158-04(1)(2)	3.8	4.0	200	866	780	346
68.0	*B	T495B686M010AS		6.8	10.0	900	307	276	123
68.0	*C	T495C686(1)010AS		6.8	6.0	225	700	630	280
68.0	*V	T495V686(1)010AS		6.8	6.0	140	945	850	378
68.0	D	T495D686(1)010AS		6.8	6.0	150	1000	900	400
68.0	X	T495X686(1)010AS		5.4	4.0	150	1049	944	420
68.0	X	T495X686(1)010AS4095	95158-05(1)(2)	5.4	4.0	150	1049	944	420
100.0	*V	T495V107(1)010AS		10.0	8.0	150	913	822	365
100.0	*D	T495D107(1)010AS		10.0	8.0	100	1220	1100	490
100.0	*D	T495D107(1)010AS4095	95158-06(1)(2)	10.0	8.0	100	1220	1100	490
100.0	*D	T495D107(1)010AS4823		10.0	8.0	80	1369	1232	548
100.0	X	T495X107(1)010AS		8.0	6.0	100	1285	1156	514
100.0	X	T495X107(1)010AS4095	95158-07(1)(2)	8.0	6.0	100	1285	1156	514
150.0	V	T495V157M010AS		15.0	8.0	150	913	822	365
150.0	*D	T495D157(1)010AS		15.0	8.0	100	1225	1102	490
150.0	*D	T495D157(1)010AS4095	95158-26(1)(2)	15.0	8.0	100	1225	1102	490
150.0	*X	T495X157(1)010AS		15.0	8.0	100	1285	1156	514
150.0	*X	T495X157(1)010AS4095	95158-08(1)(2)	15.0	8.0	100	1285	1156	514
150.0	*X	T495X157(1)010AS4823		15.0	8.0	85	1393	1254	557
220.0	*V	T495V227(1)010AS		22.0	12.0	150	913	822	365
220.0	*D	T495D227(1)010AS		22.0	8.0	125	1095	986	438
220.0	*X	T495X227(1)010AS		22.0	8.0	100	1285	1156	514
220.0	*X	T495X227(1)010AS4095	95158-28(1)(2)	15.0	8.0	100	1285	1156	514
220.0	*X	T495X227(1)010AS4823		22.0	8.0	70	1535	1382	614
330.0	*D	T495D337(1)010AS		33.0	10.0	125	1095	986	438
330.0	*X	T495X337(1)010AS		33.0	10.0	60	1658	1492	663
<b>16 Volt Rating @ +85°C (10 Volt Rating at +125°C)</b>									
10.0	*T	T495T106M016AS		1.6	8.0	4000	132	119	53
33.0	*C	T495C336(1)016AS		5.3	6.0	275	632	569	253
33.0	*D	T495D336(1)016AS		4.2	4.0	225	816	735	327
33.0	*D	T495D336(1)016AS4095	95158-09(1)(2)	4.2	4.0	250	770	700	310
47.0	*D	T495D476(1)016AS		7.5	6.0	150	1000	900	400
47.0	*D	T495D476(1)016AS4095	95158-10(1)(2)	7.5	6.0	200	870	780	345
68.0	*V	T495V686(1)016AS		10.9	6.0	300	645	581	258
68.0	*D	T495D686(1)016AS		10.9	6.0	150	1000	900	400
100.0	*D	T495D107(1)016AS		16.0	8.0	125	1095	986	438
100.0	*X	T495X107(1)016AS		16.0	8.0	100	1285	1156	514
100.0	*X	T495X107(1)016AS4095	95158-11(1)(2)	16.0	8.0	125	1149	1034	460
100.0	*X	T495X107(1)016AS4823		16.0	8.0	80	1436	1293	574
150.0	*X	T495X157(1)016AS		24.0	8.0	100	1285	1156	514

- (1) To complete KEMET Part Number, insert M for  $\pm 20\%$  or K for  $\pm 10\%$  tolerance.  
 (2) To complete KEMET Part Number, insert "B" for gold plated or "H" for solder plated termination finish. \*Extended Values\*\*6 Volt product equivalent to 6.3 volt product.  
 Note: Refer to T495 Ordering Information below for lead termination options.

Higher voltage ratings and tighter capacitance tolerance product may be substituted within the same size at KEMET's option. Voltage substitutions will be marked with the higher voltage rating.

### T495 Series - ORDERING INFORMATION

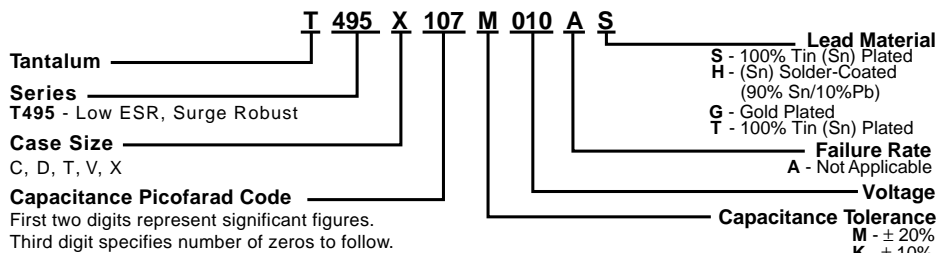

\* See [www.kemet.com](http://www.kemet.com) for Pb Free transition information.

# SOLID TANTALUM CHIP CAPACITORS

## T495 SERIES—Low ESR, Surge Robust



### T495 RATINGS & PART NUMBER REFERENCE

Capacitance $\mu\text{F}$	Case Size	KEMET Part Number	DSCC Dwg. No. 95158 Part Number	DC Leakage $\mu\text{A}$ @ 25°C Max	DF% @ 25°C 120 Hz Max	ESR mW @ 25°C 100 kHz Max	Ripple Current mA rms at 25°C, 100 kHz Max		
							25°C	85°C	125°C
<b>20 Volt Rating @ +85°C (13 Volt Rating at +125°C)</b>									
15.0	D	T495D156(1)020AS		2.4	4.0	275	738	665	295
15.0	D	T495D156(1)020AS4095	95158-12(1)(2)	2.4	4.0	275	738	665	295
22.0	D	T495D226(1)020AS		3.5	4.0	225	816	735	326
22.0	D	T495D226(1)020AS4095	95158-13(1)(2)	3.5	4.0	275	739	665	295
33.0	*D	T495D336(1)020AS		6.6	6.0	200	866	780	346
47.0	*D	T495D476(1)020AS		9.4	6.0	175	926	833	370
47.0	X	T495X476(1)020AS		7.5	4.0	150	1049	944	420
47.0	X	T495X476(1)020AS4095	95158-14(1)(2)	7.5	4.0	150	1049	944	420
68.0	*D	T495D686(1)020AS		13.6	8.0	150	1000	900	400
68.0	*X	T495X686(1)020AS		13.6	6.0	150	1049	944	420
68.0	*X	T495X686(1)020AS4095	95158-15(1)(2)	13.6	6.0	150	1049	944	420
<b>25 Volt Rating @ +85°C (17 Volt Rating at +125°C)</b>									
6.8	C	T495C685(1)025AS		1.7	6.0	500	469	422	188
10.0	*C	T495C106(1)025AS		2.5	6.0	450	494	445	198
15.0	D	T495D156(1)025AS		3.8	6.0	275	738	665	295
15.0	D	T495D156(1)025AS4095	95158-16(1)(2)	3.8	6.0	275	738	665	295
15.0	X	T495X156(1)025AS		3.0	4.0	200	908	817	363
15.0	X	T495X156(1)025AS4095	95158-17(1)(2)	3.0	4.0	200	908	817	363
22.0	*D	T495D226(1)025AS		5.5	6.0	200	866	780	346
22.0	X	T495X226(1)025AS		4.4	4.0	225	856	771	343
22.0	X	T495X226(1)025AS4095	95158-18(1)(2)	4.4	4.0	225	856	771	343
33.0	*D	T495D336(1)025AS		8.3	6.0	300	707	636	283
33.0	X	T495X336(1)025AS		6.6	4.0	175	971	874	388
33.0	X	T495X336(1)025AS4095	95158-19(1)(2)	6.6	4.0	175	971	874	388
47.0	X	T495X476M025AS		11.8	6.0	200	908	817	363
68.0	*X	T495X686(1)025AS		17.0	8.0	200	908	817	363
<b>35 Volt Rating @ +85°C (23 Volt Rating at +125°C)</b>									
4.7	*C	T495C475(1)035AS		1.7	6.0	600	428	385	171
4.7	*C	T495C475(1)035AS4095	95158-29(1)(2)	1.7	6.0	600	428	385	171
6.8	*D	T495D685(1)035AS		2.4	6.0	400	612	551	245
6.8	X	T495X685(1)035AS		1.9	4.0	300	742	667	297
6.8	X	T495X685(1)035AS4095	95158-20(1)(2)	1.9	4.0	300	742	667	297
10.0	D	T495D106(1)035AS		3.5	6.0	300	707	636	283
10.0	D	T495D106(1)035AS4095	95158-27(1)(2)	3.5	4.0	300	707	636	283
10.0	X	T495X106(1)035AS		2.8	4.0	250	812	731	325
10.0	X	T495X106(1)035AS4095	95158-21(1)(2)	2.8	4.0	250	812	731	325
15.0	*D	T495D156(1)035AS		5.3	6.0	300	707	636	283
15.0	*X	T495X156(1)035AS		5.3	6.0	225	856	771	343
15.0	*X	T495X156(1)035AS4095	95158-22(1)(2)	5.3	6.0	225	856	771	343
22.0	*D	T495D226(1)035AS		7.7	6.0	300	707	636	283
22.0	*X	T495X226(1)035AS		7.7	6.0	275	775	697	410
22.0	*X	T495X226(1)035AS4095	95158-23(1)(2)	7.7	6.0	300	742	667	297
33.0	*X	T495X336(1)035AS		11.6	6.0	250	812	731	325
47.0	*X	T495X476(1)035AS		16.5	8.0	300	742	667	297
47.0	*X	T495X476(1)035AS4823		16.5	8.0	200	908	817	363
<b>50 Volt Rating @ +85°C (33 Volt Rating at +125°C)</b>									
4.7	D	T495D475(1)050AS		2.4	6.0	300	707	636	283
4.7	X	T495X475(1)050AS		1.9	4.0	300	742	667	297
4.7	X	T495X475(1)050AS4095	95158-24(1)(2)	1.9	4.0	300	742	667	297
6.8	*D	T495D685(1)050AS		3.4	8.0	300	700	600	300
	*X	T495X106(1)050AS		5.0	6.0	300	741	667	297
15.0	*X	T495X156(1)050AS		7.5	8.0	300	742	667	297

Higher voltage ratings and tighter capacitance tolerance product may be substituted within the same size at KEMET's option. Voltage substitutions will be marked with the higher voltage rating

- (1) To complete KEMET and DSCC part number, insert "K" for  $\pm 10\%$  or "M" for  $\pm 20\%$  capacitance
- (2) To complete DSCC part number, insert "B" for gold plated or "H" for solder plated termination finish.

Note: Refer to T495 Ordering Information on page 32 \* Extended Values \*\* 6 Volt product equivalent to 6.3 volt product. for lead termination options.

### CONSTRUCTION

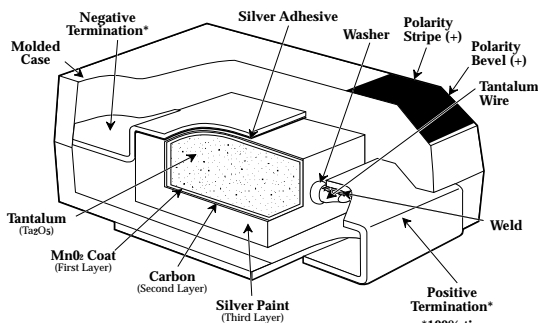

### CAPACITOR MARKINGS

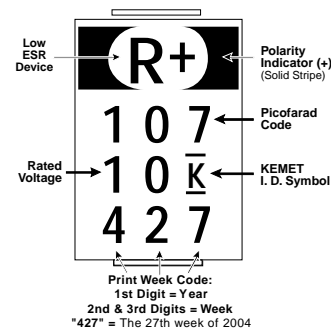

## T495 TANTALUM CHIP CAPACITANCE VALUES

Case Size and Max. ESR (mΩ) by Capacitance & Voltage  
Standard Capacitance Values

Capacitance		Rated Voltage @ +85°C							
μF	Code	4	6	10	16	20	25	35	50
4.7	475							C,600 D,400	X,300
6.8	685						C,500	X,300	
10.0	106							D,300 X,250	
15.0	156					D,275	D,275 X,200		
22.0	226			C,345		D,225 D,275	X,225		
33.0	336				D,250		X,175		
47.0	476			D,200		X,150			
68.0	686		D,175	D,150 X,150					
100.0	107			X,100					
150.0	157		X,100						
220.0	227								
330.0	337								

### Extended Capacitance Values

Capacitance		Rated Voltage @ +85°C							
μF	Code	4	6	10	16	20	25	35	50
4.7	475								
6.8	685								D,300
10.0	106				T,4000		C,450		X, 300
15.0	156							D,300 X,225	X,300
22.0	226						D,200	D,300 X,275	
33.0	336				C,275	D,200	D,300	X,250	
47.0	476				D,150 D,200	D,175	X,200	X,300	
68.0	686			B, 900 C, 225 V, 140	D,150 V,300	D,150 X,150	X,200		
100.0	107		V,150 C,150	D, 150 D, 100 D, 80*	D,125 X, 100 X, 80* X,125				
150.0	157	B,900	C,200	D,100 X,100 X,85* V,150	X,100				
220.0	227		C, 225 D, 100 X, 100	D,125 X, 100 X, 70* V,150					
330.0	337	C,700	X, 100 X, 65* D, 100	X, 60 D, 125					
470.0	477		X, 65 X, 50* D, 125						
1000.0	108	X,70							

Note that standard values are preferred, especially where high surge currents are possible. Extended values are available to increase capacitance and reduce ESR. Note that standard CV values demonstrate inherently lower failure rates than extended CV values, especially in low impedance applications.

\* Super Low ESR limits available with part number suffix 4823.