

# Schematic:

REV.	ECN NO.	DESCRIPTION	DATE	APPD
A	REL		2011/03/05	

LAN CHIP SIDE

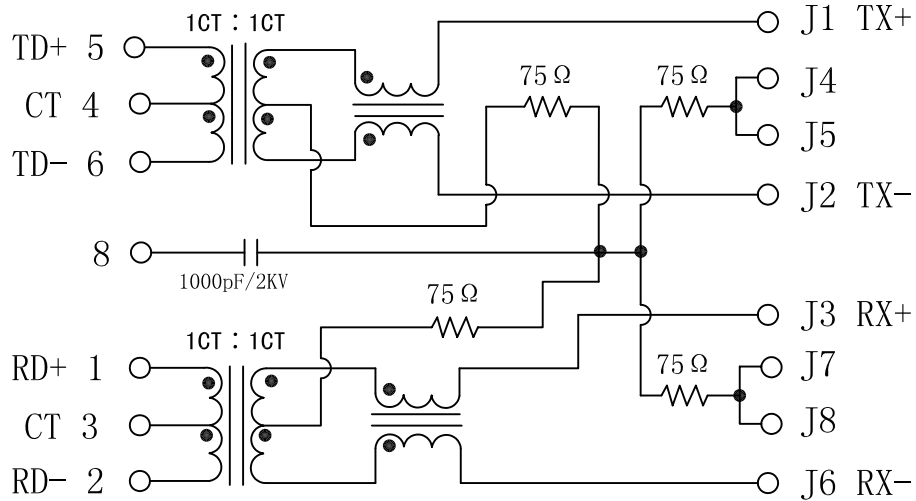

RJ CABLE SIDE

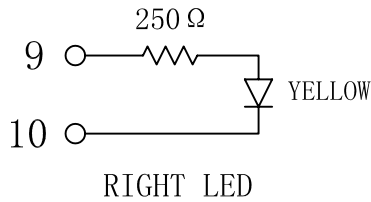
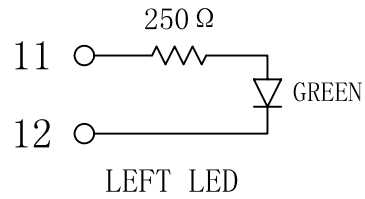

## Electrical Specifications @25°C

- Turns Ratio ( $\pm 2\%$ ) :  
TX=1CT:1CT      RX=1CT:1CT
- Primary Inductance(1-2, 5-6): 350uH min  
@100KHz, 0.1Vrms, 8mA DC bias
- Insertion Loss:  
0.5-100MHz: -1.1dB Max
- Return Loss(dB Min) :  
0.5-30MHz:-18;  
30.1-60MHz:-[18-20LOG(f/30)]  
60.1-80MHz:-12
- Crosstalk(dB Min):  
0.5-40MHz: -35  
40.1-100MHz: -[33-20LOG(f/50)]
- Common Mode Rejection Ratio:  
0.5-100MHz: -30dB Min
- Hipot Test: 1500Vrms
- Operating Temperature: 0°C ~ 70°C.



X:X	$\pm 0.20$	APPD:	LINK-PP INT'L TECHNOLOGY CO., LIMITED
X:XX	$\pm 0.10$	CHKD:	
X:XXX	$\pm 0.05$	DR: TOM	
ANGLES	$\pm 1^\circ$	UNIT: mm	PART NO. : LPJ16264A28NL
	SCALE: 2/1	SHEET: 1/2	REV: A    DWG NO: LP11030506

# Mechanical:

REV.	ECN NO.	DESCRIPTION	DATE	APPD
A	REL		2011/03/05	

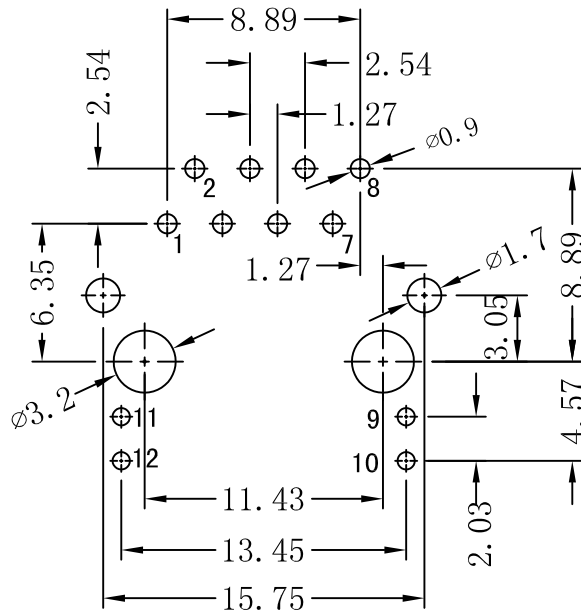
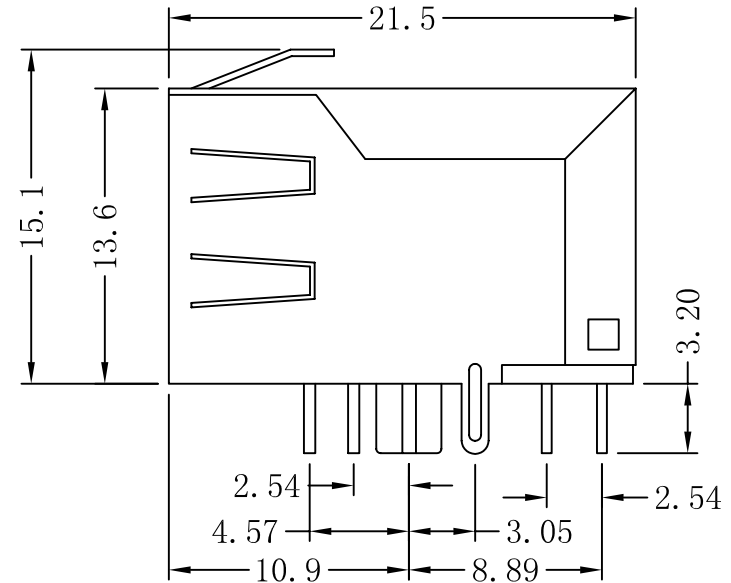
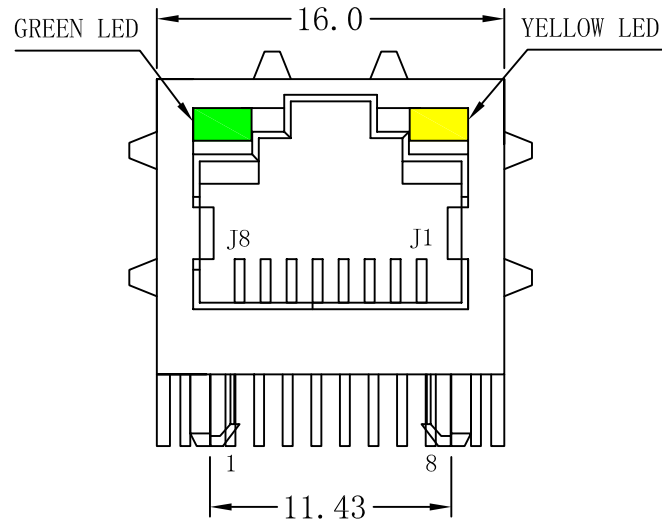

SUGGESTED PCB LAYOUT (TOP VIEW)



## NOTES:

1. Designed to support application, such as SOHO (ADSL modems), LAN-on-Motherboard (LOM), hub and Switches.
2. Meets IEEE 802.3 specification
3. Connector Materials:  
Housing: Thermoplastic UL94V-0  
Contact/Shield: Copper alloy  
Shield plating: Nickel  
Contact plating: Gold 6 micro-inches min. In contact area.
4. Wave solder tip temperature: 265°C MAX  
Wave solder tip temperature time: 5 Sec MAX.

X:X	±0.20	APPD:	LINK-PP INT'L TECHNOLOGY CO., LIMITED	
X:XX	±0.10	CHKD:	Title: RJ45 Connector With 10/100 Base-TX Integrated Magnetic TAB-UP	
X:XXX	±0.05	DR: TOM		
ANGLES	±1°	UNIT: mm	PART NO.:	LPJ16264A28NL
	SCALE: 2/1	SHEET: 2/2	REV: A	DWG NO: LP11030506