

Schematic:

REV.	ECN NO.	DESCRIPTION	DATE	APPD
A	REL		05/08/2009	

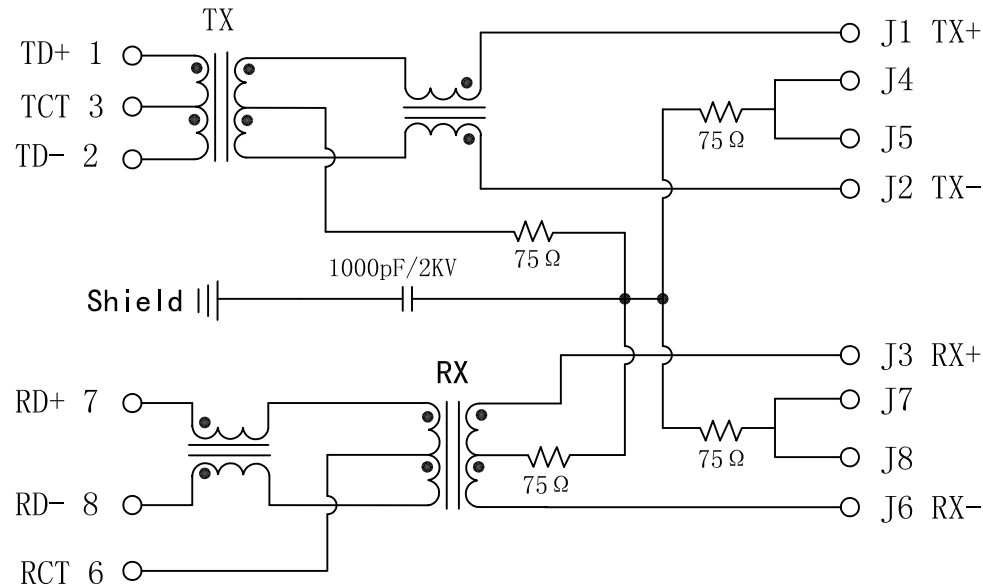

GREEN/LEFT LED

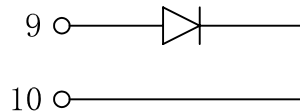

YELLOW/RIGHT LED

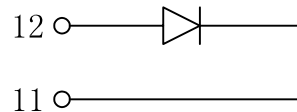

Electrical Specifications @25°C

- Turns Ratio:  
TX=1CT:1CT      RX=1CT:1CT
- Inductance OCL (100KHz, 0.1V, 8mA):  
350uH Min
- Insertion Loss:  
1~65MHz:-1.0dB Max
- Return Loss (dB Min):  
1~30MHz:-18;      40MHz:-16;  
50MHz:-12;      60MHz:-10
- Crosstalk (dB Min):  
30MHz:-40;      60MHz:-35;  
100MHz:-30.
- CMR: (dB Min):  
30MHz:-30;      60MHz:-20;  
100MHz:-20
- HI-POT: 1500Vrms
- Operating Temperature: -40~+85°C.

X:X ±0.25	APPD:	LINK-PP INT'L TECHNOLOGY CO., LIMITED		
X:XX ±0.20	CHKD:	TITLE: RJ45 Connector with 10/100 Base-T Integrated Magnetics		
X:XXX ±0.05	DR: TOM	PART NO.: LPJ4126ABNL		
ANGLES ±1°	UNIT: mm			
	SCALE: 2/1	SHEET: 1/2	REV: A	DWG NO.: LP09080508

Mechanical:

REV.	ECN NO.	DESCRIPTION	DATE	APPD
A	REL		05/08/2009	

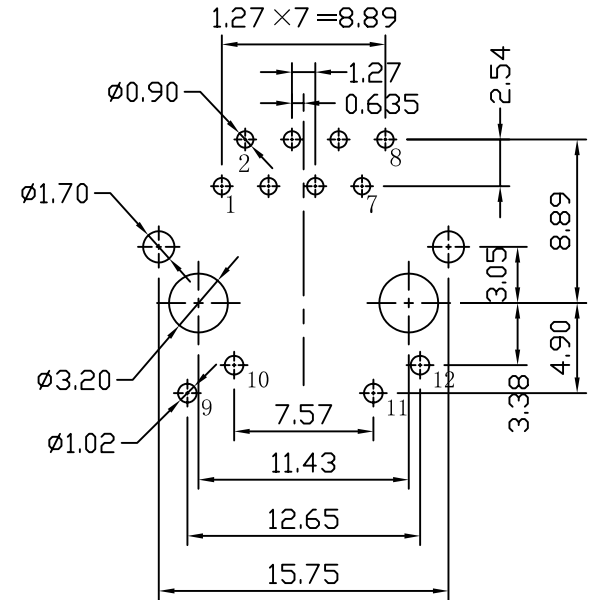
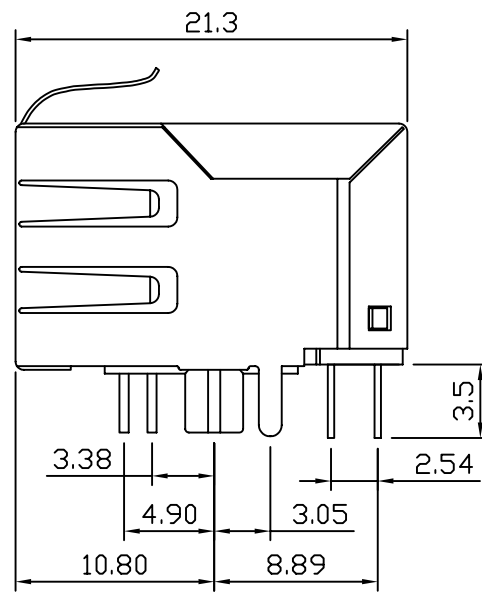
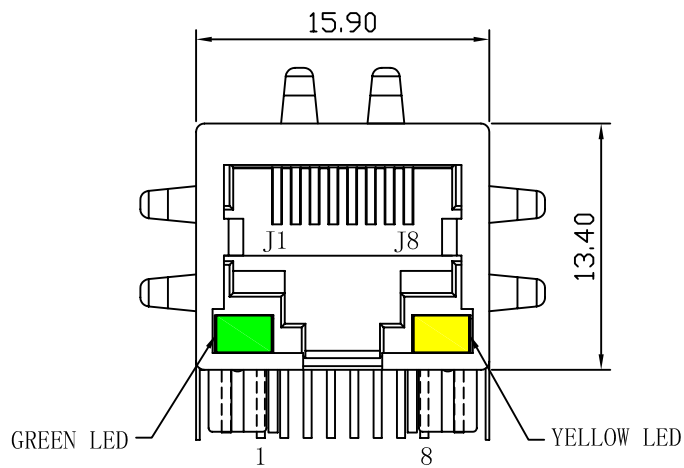

SUGGESTED PCB LAYOUT (TOP VIEW)

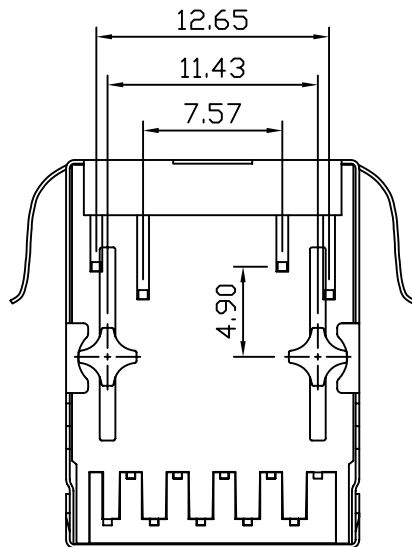

NOTES:

1. Designed to support application, such as SOHO (ADSL modems), LAN-on-Motherboard (LOM), hub and Switches.
2. Meets IEEE 802.3 specification
3. Connector Materials:  
 Housing: Thermoplastic UL94V-0  
 Contact/Shield: Copper alloy  
 Shield plating: Nickel  
 Contact plating: Gold 6 micro-inches min. In contact area.
4. Wave solder tip temperature: 265°C Max  
 Wave solder tip temperature time: 5 Sec Max



X:X ±0.25	APPD:	LINK-PP INT'L TECHNOLOGY CO., LIMITED
X:XX ±0.20	CHKD:	
X:XXX ±0.05	DR: TOM	TITLE: RJ45 Connector with 10/100 Base-T Integrated Magnetics
ANGLES ±1°	UNIT: mm	PART NO.: LPJ4126ABNL
	SCALE: 2/1	SHEET: 2/2
	REV: A	DWG NO.: LP09080508